



Pro Xp™ Electrostatic

Air-Assisted Spray Gun

3A2495F
EN

For use in Class I, Div. I Hazardous Locations using Group D materials.
For use in Group II, Zone 1 Explosive Atmosphere Locations using Group IIA materials. For professional use only.



Important Safety Instructions

This equipment could present hazards if not operated according to the information in this manual. **Read all warnings and instructions in this manual. Save these instructions.**

*3000 psi (21 MPa, 210 bar) Maximum
Fluid Working Pressure*

*100 psi (0.7 MPa, 7 bar) Maximum Air
Working Pressure*

*See page 3 for model part numbers and
approval information.*

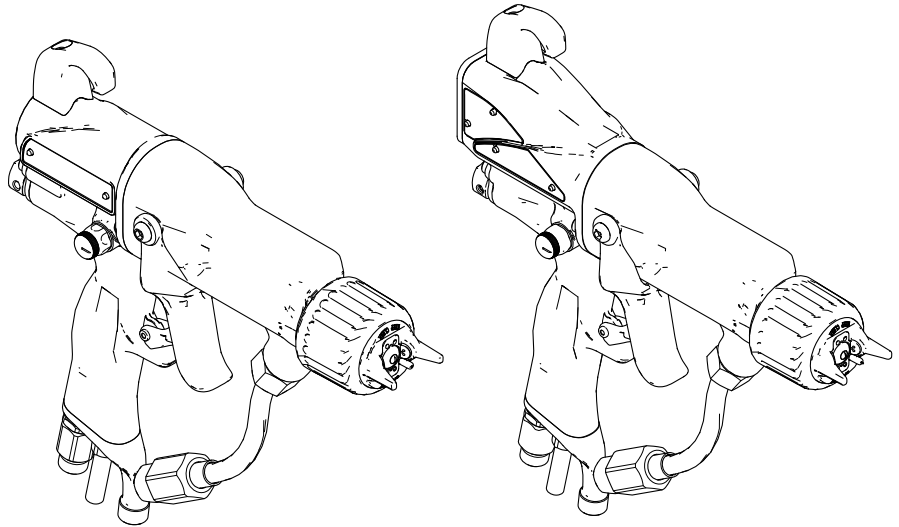

ti18643a

Contents

Models	3	Fluid Tube Removal and Replacement	42
Warnings	4	Fluid Filter Replacement.....	42
Gun Overview	7	Gun Barrel Removal.....	43
How the Electrostatic AA Spray Gun		Gun Barrel Installation.....	43
Works	7	Fluid Needle Replacement.....	44
Controls, Indicators, and Components	8	Power Supply Removal and	
Smart Guns	9	Replacement.....	45
Installation.....	15	Alternator Removal and Replacement	46
Warning Sign.....	15	Fan Air Adjustment Valve Repair	48
Ventilate the Spray Booth	15	Atomizing Air Adjustment Valve	
Air Supply Line	16	Repair.....	49
Fluid Supply Line	16	ES On-Off Valve Repair	50
Gun Setup.....	18	Air Valve Repair.....	51
Gun Setup Checklist	18	Smart Module Replacement.....	52
Grounding	21	Air Swivel and Exhaust Valve	
Check Gun Electrical Grounding	25	Replacement.....	53
Check Fluid Resistivity	26	Parts.....	54
Check Fluid Viscosity	26	Standard Air-Assisted Spray Gun	
Flush Before Using Equipment.....	26	Assembly	54
Operation.....	27	Smart Air-Assisted Spray Gun	
Pressure Relief Procedure.....	27	Assembly	56
Startup	27	Alternator Assembly	58
Shutdown	27	ES On-Off Valve Assembly.....	59
Maintenance	28	Fan Air Valve Assembly	60
Flushing	28	Air Cap Assembly	61
Clean the Gun Daily	29	Smart Module Assembly.....	61
Daily System Care	31	Spray Tip Selection Chart.....	62
Electrical Tests	32	AEM Fine Finish Spray Tips.....	62
Test Gun Resistance.....	32	AEF Fine Finish Pre-Orifice Spray	
Test Power Supply Resistance	33	Tips	63
Test Gun Barrel Resistance.....	34	Repair Kits, Related Manuals, and	
Troubleshooting.....	35	Accessories	64
Spray Pattern Troubleshooting.....	35	Gun Accessories.....	64
Gun Operation Troubleshooting	36	System Accessories.....	64
Electrical Troubleshooting	37	Test Equipment	64
Repair.....	39	Hoses	65
Prepare the Gun for Service	39	Operator Accessories.....	65
Air Cap, Spray Tip, and Fluid Seat Housing		Dimensions	66
Replacement.....	40	Technical Data	67
Electrode Replacement	41	Graco Pro Xp Warranty.....	68

Models

Part No.	kV	Smart Display	Standard Display
H60T10	60		✓
H60M10	60	✓	
H85T10	85		✓
H85M10	85	✓	



II 2 G

EEx 0.24 mJ T6

FM12ATEX0068







EN 50050







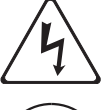

Ta 0°C – 50°C



Warnings

The following warnings are for the setup, use, grounding, maintenance and repair of this equipment. The exclamation point symbol alerts you to a general warning and the hazard symbol refers to procedure-specific risks. When these symbols appear in the body of this manual or on warning labels, refer back to these Warnings. Product-specific hazard symbols and warnings not covered in this section may appear throughout the body of this manual where applicable.

 WARNING	
    	<p>FIRE, EXPLOSION, AND ELECTRIC SHOCK HAZARD</p> <p>Flammable fumes, such as solvent and paint fumes, in work area can ignite or explode. Paint or solvent flowing through the equipment can cause static sparking. To help prevent fire, explosion, and electric shock:</p> <ul style="list-style-type: none">• Electrostatic equipment must be used only by trained, qualified personnel who understand the requirements of this manual.• Ground all equipment, personnel, object being sprayed, and conductive objects in or close to spray area. Resistance must not exceed 1 megohm. See Grounding instructions.• Only use grounded Graco conductive air supply hoses.• Do not use pail liners unless they are conductive and grounded.• Stop operation immediately if static sparking occurs or you feel a shock. Do not use equipment until you identify and correct the problem.• Check gun resistance, hose resistance, and electrical grounding daily.• Use and clean equipment only in well ventilated area.• Interlock the gun air and fluid supply to prevent operation unless ventilation air flow is above the minimum required value.• Use only Group IIA or Group D materials.• Use cleaning solvents with highest possible flash point when flushing or cleaning equipment.• Never spray or flush solvent at high pressure.• To clean the exterior of the equipment, cleaning solvents must have a flash point at least 15°C above ambient temperature. Non-ignitable fluids are preferred.• Always turn the electrostatics off when flushing, cleaning or servicing equipment.• Eliminate all ignition sources; such as pilot lights, cigarettes, portable electric lamps, and plastic drop cloths (potential static sparking).• Do not plug or unplug power cords or turn lights on or off when flammable fumes are present.• Keep spray area free of debris, including solvent, rags and gasoline. Keep the spray area clean at all times. Use non-sparking tools to clean residue from the booth and hangers.• Keep a working fire extinguisher in the work area.

 <h1 style="margin: 0;">WARNING</h1>	
  	<p>SKIN INJECTION HAZARD High-pressure fluid from gun, hose leaks, or ruptured components will pierce skin. This may look like just a cut, but it is a serious injury that can result in amputation. Get immediate surgical treatment.</p> <ul style="list-style-type: none"> • Do not spray without tip guard and trigger guard installed. • Engage trigger lock when not spraying. • Do not point gun at anyone or at any part of the body. • Do not put your hand over the spray tip. • Do not stop or deflect leaks with your hand, body, glove, or rag. • Follow the Pressure Relief Procedure when you stop spraying and before cleaning, checking, or servicing equipment. • Tighten all fluid connections before operating the equipment. • Check hoses and couplings daily. Replace worn or damaged parts immediately.
 	<p>PLASTIC PARTS CLEANING SOLVENT HAZARD Many solvents can degrade plastic parts and cause them to fail, which could cause serious injury or property damage.</p> <ul style="list-style-type: none"> • Use only compatible water-based solvents to clean plastic structural or pressure-containing parts. • See Technical Data in this and all other equipment instruction manuals. Read fluid and solvent manufacturer's MSDSs and recommendations.
	<p>TOXIC FLUID OR FUMES Toxic fluids or fumes can cause serious injury or death if splashed in the eyes or on skin, inhaled, or swallowed.</p> <ul style="list-style-type: none"> • Read MSDSs to know the specific hazards of the fluids you are using. • Store hazardous fluid in approved containers, and dispose of it according to applicable guidelines.
	<p>PERSONAL PROTECTIVE EQUIPMENT Wear appropriate protective equipment when in the work area to help prevent serious injury, including eye injury, hearing loss, inhalation of toxic fumes, and burns. This protective equipment includes but is not limited to:</p> <ul style="list-style-type: none"> • Protective eyewear, and hearing protection. • Respirators, protective clothing, and gloves as recommended by the fluid and solvent manufacturer.



WARNING





EQUIPMENT MISUSE HAZARD

Misuse can cause death or serious injury.

- Do not operate the unit when fatigued or under the influence of drugs or alcohol.
- Do not exceed the maximum working pressure or temperature rating of the lowest rated system component. See **Technical Data** in all equipment manuals.
- Use fluids and solvents that are compatible with equipment wetted parts. See **Technical Data** in all equipment manuals. Read fluid and solvent manufacturer's warnings. For complete information about your material, request MSDS from distributor or retailer.
- Do not leave the work area while equipment is energized or under pressure.
- Turn off all equipment and follow the **Pressure Relief Procedure** when equipment is not in use.
- Check equipment daily. Repair or replace worn or damaged parts immediately with genuine manufacturer's replacement parts only.
- Do not alter or modify equipment. Alterations or modifications may void agency approvals and create safety hazards.
- Make sure all equipment is rated and approved for the environment in which you are using it.
- Use equipment only for its intended purpose. Call your distributor for information.
- Route hoses and cables away from traffic areas, sharp edges, moving parts, and hot surfaces.
- Do not kink or over bend hoses or use hoses to pull equipment.
- Keep children and animals away from work area.
- Comply with all applicable safety regulations.

Gun Overview

How the Electrostatic AA Spray Gun Works

				
<p>This is not an air spray gun. To help prevent serious injury from pressurized fluid, such as skin injection, and splashing fluid, read and follow the Skin Injection Hazard Warnings on page 5.</p>				

The air-assisted spray gun combines airless and air spraying concepts. The spray tip atomizes and shapes the fluid into a fan pattern, as does a conventional airless spray tip. Air from the air cap further atomizes the fluid and completes the atomization of the fluid tails to produce a uniform pattern.

As the gun is triggered, part of the regulated air operates the alternator turbine and the rest of the air helps atomize the fluid being sprayed. The

alternator generates power, which is converted by the power cartridge to supply high voltage to the gun's electrode.

The fluid is electrostatically charged as it passes the electrode. The charged fluid is attracted to the grounded workpiece, wrapping around and evenly coating all surfaces.

The regulated air that is directed to the air cap can be further controlled using the gun's atomizing air adjustment valve. This valve can be used to restrict air flow to the air cap while maintaining sufficient air flow to the alternator. The atomizing air adjustment valve does not control pattern width. To change pattern width, use a new tip size, or use the fan adjustment to narrow the pattern width.

The high working fluid pressure of this gun provides the power needed to atomize higher solids materials.

NOTE: For airless atomization, if desired, turn the gun's atomizing air adjustment valve completely off. Closing this valve does not affect alternator operation.

Controls, Indicators, and Components

The electrostatic gun includes the following controls, indicators, and components (see Fig. 1). For information on Smart guns, also see [Smart Guns, page 9](#).

Item	Description	Purpose
A	Air Swivel Inlet	1/4 npsm(m) left-hand thread, for Graco grounded air supply hose.
B	Fluid Inlet	1/4 npsm(m), for fluid supply hose.
C	Turbine Air Exhaust	Barbed fitting, for supplied exhaust tube.
D	Air Cap/Tip Guard and Spray Tip	See Spray Tip Selection Chart, page 62 , for available sizes.
E	Electrode	Supplies electrostatic charge to the fluid.
F	Fan Air Adjustment Valve	Adjusts fan size and shape. Can be used to decrease pattern width.

Item	Description	Purpose
G	Atomizing Air Adjustment Valve	Adjusts atomizing air flow.
H	Trigger Safety Lock	Locks trigger to prevent gun from spraying.
J	ES On-Off Valve	Turns electrostatics ON (I) or OFF (O).
K	ES Indicator (standard gun only; for Smart gun indicator, see Operating Mode, page 9)	Lit when ES is ON (I). Color indicates alternator frequency. See the LED indicator table in the Gun Setup Checklist, page 18 .
L	Inline Fluid Filter	Provides final filtration of fluid. Located inside fluid tube fitting.

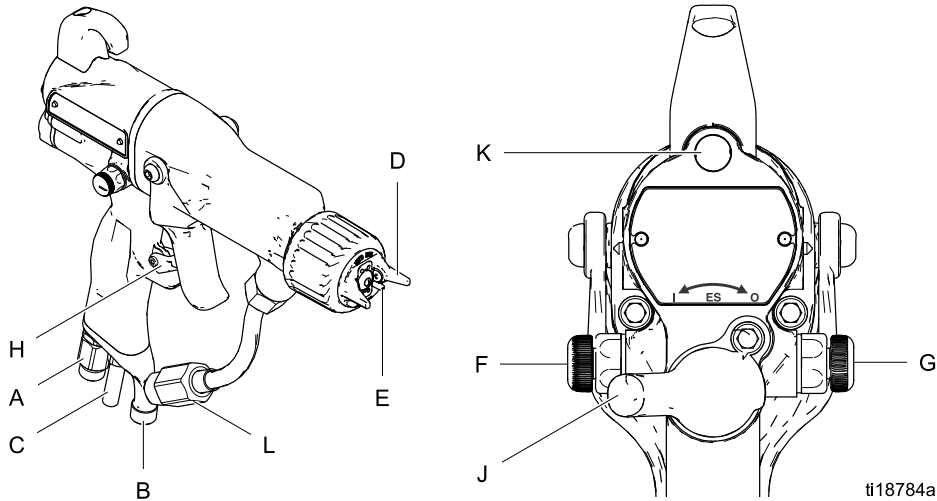

Figure 1 Gun Overview

Smart Guns

The Smart Gun module displays spraying voltage, current, alternator speed, and the voltage setting (low or high). It also allows the user to change to a lower spraying voltage. The module has two modes:

- Operating Mode
- Diagnostic Mode

Operating Mode

Bar Graph

See Fig. 2, and Table 1 on page 11. The Operating Mode displays gun data during normal spraying. The display uses a bar graph to show the voltage level in kiloVolts (kV) and the current level in microAmperes (μ A). The bar graph range is from 0 to 100% for each value.

If the μ A bar graph LEDs are blue, the gun is ready to spray. If the LEDs are yellow or red, the current is too high. The fluid may be too conductive, or see [Electrical Troubleshooting, page 37](#) for other possible causes.

Hz Indicator

The Hz indicator functions the same as the ES indicator on standard guns. The indicator lights to show the alternator speed status, and has three colors:

- Green indicates the alternator speed is correct.
- If the indicator changes to amber after 1 second, increase the air pressure.
- If the indicator changes to red after 1 second, the air pressure is too high. Decrease air pressure until the indicator is green. To maintain a higher air pressure, install ES On/Off Valve Restrictor Kit 26A294. Then, adjust the pressure as needed to ensure operation in the green light.

Voltage Adjustment Switch

The voltage adjustment switch (VA) allows the operator to change from low to high voltage.

- The high voltage setting is determined by the maximum voltage of the gun and is not adjustable.
- The low voltage indicator (LO) lights when the switch is set to LO. The low voltage setting is user adjustable. See [Adjusting the Low Voltage Setting, page 10](#).

NOTE: If the Error display appears, the Smart module has lost communication with the power supply. See [Error Display, page 10](#), for further information.

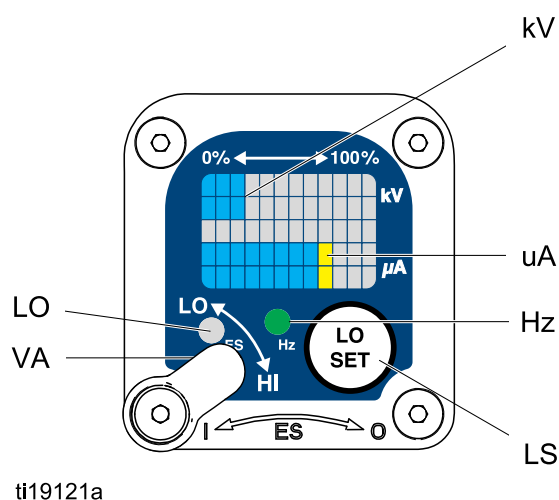

ti19121a

Figure 2 Smart Gun Module in Operating Mode

Error Display

If the Smart module loses communication with the power supply, the Error display appears, the Hz indicator turns red, and the Smart module is disabled. See Fig. 3, and Table 1 on page 11. This can occur in Operating Mode or Diagnostic Mode. See [Electrical Troubleshooting, page 37](#). Communication must be restored to make the Smart module functional.

NOTE: It takes 8 seconds for the Error display to appear. If the gun has been disassembled, wait 8 seconds before spraying to ensure that an Error condition has not occurred.

NOTE: If there is no power to the gun, the Error display will not appear.

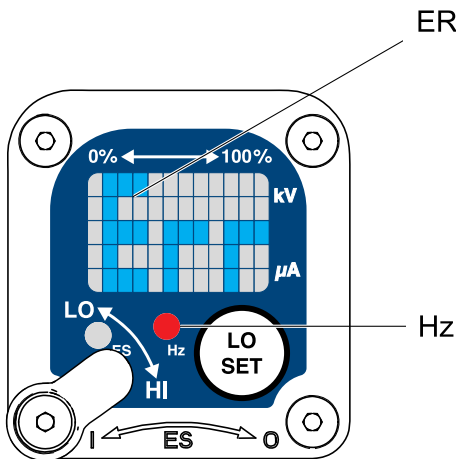

ti19338a

Figure 3 Error Display

Adjusting the Low Voltage Setting

The low voltage setting is user adjustable. To access the low voltage setting screen when in Operating Mode, press the LO SET button (LS) momentarily. The screen will display the current low voltage setting. See Fig. 4, and Table 1 on page 11. The possible ranges are:

- 85 kV guns: 40–85 kV
- 60 kV guns: 30–60 kV

Set the Voltage Adjustment switch (VA) to LO. Press the LO SET button repeatedly to increase the setting in increments of 5. When the display reaches the maximum setting it will return to the minimum setting

for your gun. Continue pressing the button until you reach the desired setting.

NOTE: After 2 seconds of inactivity the display will return to the Operating Screen.

NOTE: The low voltage setting may be locked. See [Lock Symbol, page 10](#).

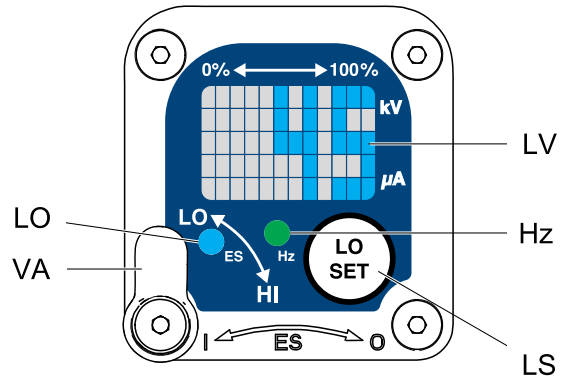

ti19122a

Figure 4 Low Voltage Setting Screen (Unlocked)

Lock Symbol

The low voltage setting may be locked. When locked, an image (LK) appears on the screen. See Fig. 5, and Table 1 on page 11.

- When in HI mode, the low voltage setting is **always** locked. The lock symbol will appear when the LO SET button is pressed.
- In LO mode, the lock symbol will only appear if the lock is enabled. See [Low Voltage Lock Screen, page 14](#), to lock or unlock the low voltage setting.

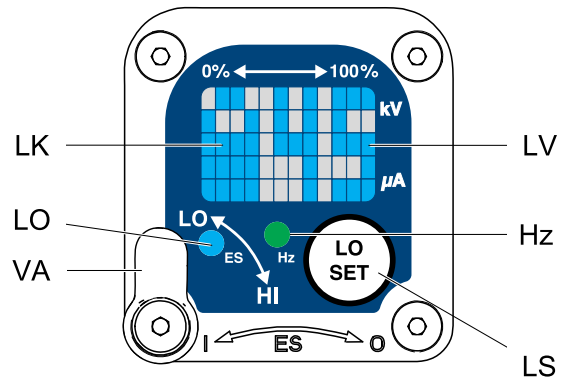

ti19337a

Figure 5 Low Voltage Setting Screen (Locked)

Table 1 . Key for Figs. 2–9.

Item	Description	Purpose
VA	Voltage Adjustment Switch	Two-position switch sets smart gun voltage to low setting (LO) or high setting (HI). This switch is functional in Operating Mode and in Diagnostic Mode.
LO	Low Voltage Mode Indicator	Lights (blue) when the smart gun is set to Low Voltage.
kV	Voltage (kV) Display	Displays actual spraying voltage of the gun, in kV. In Operating Mode, display is a bar graph. In Diagnostic Mode, voltage is displayed as a number.
uA	Current (uA) Display	Displays actual spraying current of the gun, in uA. In Operating Mode, display is a bar graph. In Diagnostic Mode, current is displayed as a number.
LS	LO SET button	<p>Press momentarily to enter the Low Voltage Setting screen.</p> <p>Press and hold for approximately 5 seconds to enter or exit Diagnostic Mode.</p> <p>While in Diagnostic Mode, press momentarily to advance through screens.</p> <p>While on the Low Voltage Lock Screen (in Diagnostic Mode), press and hold to turn the lock on or off.</p>
LV	Low Voltage Display	Displays the low voltage setting as a number. The setting can be changed. See Fig. 4.
LK	Low Voltage Locked	Appears if the low voltage setting is locked. See Fig. 5 and Fig. 9.

Item	Description	Purpose
LD	Lo Display	Appears on the Low Voltage Lock Screen. See Fig. 9.
ER	Error Display	Appears if the Smart module loses communication with the power supply. See Fig. 3.
VI	Voltage Indicator	In Diagnostic Mode, the two top right LEDs of the screen light, indicating that the value displayed is in kV. See Fig. 6.
CI	Current Indicator	In Diagnostic Mode, the two bottom right LEDs of the screen light, indicating that the value displayed is in uA. See Fig. 7.
AS	Alternator Speed Display	In Diagnostic Mode, Hz level is displayed as a number. See Fig. 8.
Hz	Alternator Speed Indicator	<p>In Operating Mode, indicator color varies to show the alternator speed status:</p> <ul style="list-style-type: none"> • green indicates the alternator speed is at the correct level. • If the indicator changes to amber after 1 second, the alternator speed is too low. • If the indicator changes to red after 1 second, the alternator speed is too high. The indicator will also turn red if the Error display appears. <p>In Diagnostic Mode, the indicator is green when in the Alternator Speed (Hertz) screen.</p>

Diagnostic Mode

Diagnostic Mode includes four screens which display gun data:

- Voltage (kiloVolts) Screen
- Current (microAmperes) Screen
- Alternator Speed (Hertz) Screen
- Low Voltage Lock Screen

NOTE: You must be in Operating Mode to adjust the low voltage setting; the setting is not adjustable in Diagnostic Mode. However, the voltage adjustment switch (VA) can be set to HI or LO in Operating Mode and in Diagnostic Mode.

To enter Diagnostic Mode, press and hold the LO SET (LS) button for approximately 5 seconds. The display will go to the [Voltage \(kiloVolts\) Screen, page 13](#).

To advance to the next screen, press the LO SET button again.

To exit Diagnostic Mode, press and hold the LO SET button for approximately 5 seconds. The screen will return to Operating Mode.

NOTE: If the gun is detripped while in Diagnostic Mode, the last screen viewed will be displayed when the gun is retriggered.

NOTE: Diagnostic Mode cannot be exited from the Low Voltage Lock Screen. See [Low Voltage Lock Screen, page 14](#) for details.

Voltage (kiloVolts) Screen

The Voltage (kiloVolts) Screen is the first screen to appear after entering Diagnostic Mode. See Fig. 6, and Table 1 on page 11. To enter this screen, press and hold the LO SET button for approximately 5 seconds while in the Operating Mode.

This screen displays the spraying voltage of the gun as a number (kV), rounded to the nearest 5 kV. The two top right LEDs (VI) of the display panel light, indicating that the Voltage (kiloVolts) Screen is displayed. The display is a readout and cannot be changed.

Press the LO SET button to advance to the [Current \(microAmperes\) Screen, page 13](#). Press and hold for approximately 5 seconds to return to Operating Mode.

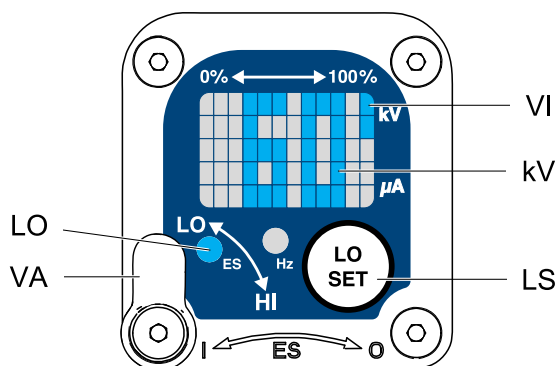

ti19123a

Figure 6 Voltage (kiloVolts) Screen

Current (microAmperes) Screen

The Current (microAmperes) Screen is the second screen in the Diagnostic Mode. See Fig. 7, and Table 1 on page 11. To enter this screen, press the LO SET button while in the Voltage (kiloVolts) Screen.

This screen displays the spraying current of the gun as a number (uA), rounded to the nearest 5 uA. The two bottom right LEDs (CI) of the display panel light, indicating that the Current (microAmperes) Screen is displayed. The display is a readout and cannot be changed.

Press the LO SET button to advance to the [Alternator Speed \(Hertz\) Screen, page 14](#). Press and hold for approximately 5 seconds to return to Operating Mode.

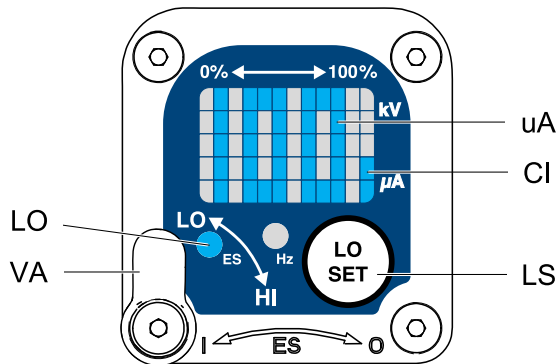

ti19124a

Figure 7 Current (microAmperes) Screen

Alternator Speed (Hertz) Screen

The Alternator Speed (Hertz) Screen is the third screen in the Diagnostic Mode. See Fig. 8, and Table 1 on page 11. To enter this screen, press the LO SET button while in the Current (microAmperes) Screen.

This screen displays the alternator speed as a 3 digit number (AS), rounded to the nearest 10 Hz. The display is a readout and cannot be changed. If the alternator speed is greater than 999 Hz, the display will show 999.

The Hz indicator lights green to show that you are viewing the Alternator Speed (Hertz) Screen.

Press the LO SET button to advance to the [Low Voltage Lock Screen, page 14](#). Press and hold for approximately 5 seconds to return to Operating Mode.

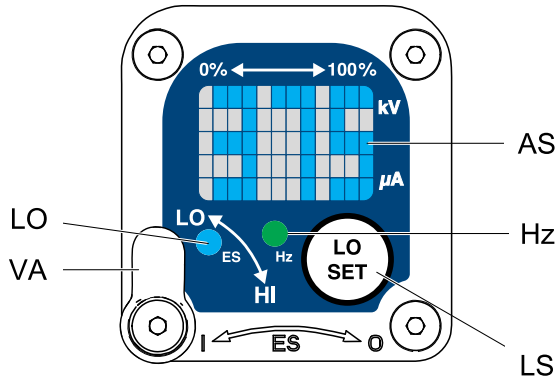

ti19125a

Figure 8 Alternator Speed (Hertz) Screen

Low Voltage Lock Screen

The Low Voltage Lock Screen is the fourth screen in the Diagnostic Mode. See Fig. 9, and Table 1 on page 11. To enter this screen, press the LO SET button while in the Alternator Speed (Hertz) Screen.

This screen displays the status of the Low Voltage Lock. If the setting is locked, the lock image (LK) appears to the left of the Lo display (LD). If the setting is unlocked, the lock image does not appear.

To change the lock status, press and hold the LO SET button until the lock image appears or disappears. If the lock is set, the image will also appear on the Low Voltage Setting Screen when in low voltage mode (see Fig. 4).

NOTE: Diagnostic Mode cannot be exited from this screen, because pressing and holding the LO SET button is used to turn the lock on or off. To exit, press LO SET momentarily to return to the Voltage (kiloVolts) Screen, then exit Diagnostic Mode from there.

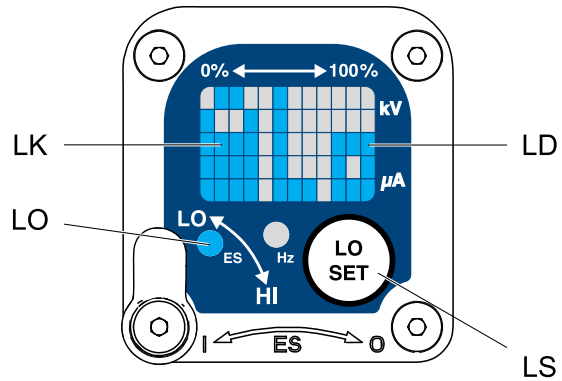

ti19339a

Figure 9 Low Voltage Lock Screen

Installation







				
<p>Installing and servicing this equipment requires access to parts which may cause electric shock or other serious injury if work is not performed properly.</p> <ul style="list-style-type: none"> • Do not install or service this equipment unless you are trained and qualified. • Be sure your installation complies with local, state, and national codes for the installation of electrical apparatus in a Class I, Div. I Hazardous Location or a Group II, Zone I Explosive Atmosphere Location. • Comply with all applicable local, state, and national fire, electrical, and other safety regulations. 				

Fig. 10 shows a typical electrostatic air-assisted spray system. It is not an actual system design. For assistance in designing a system to suit your particular needs, contact your Graco distributor.

Warning Sign

Mount warning signs in the spray area where they can easily be seen and read by all operators. An English Warning Sign is provided with the gun.



Ventilate the Spray Booth

				
<p>Provide fresh air ventilation to reduce the risk of fire or explosion caused by the buildup of flammable or toxic vapors when spraying, flushing, or cleaning the gun. Do not operate the gun unless ventilation airflow is above the minimum requirement for local standards.</p>				



Electrically interlock the gun air and fluid supply with the ventilators to prevent gun operation without ventilation airflow above minimum requirement for local standards. Check and follow all local, state, and national codes regarding air exhaust velocity requirements. Verify the operation of the interlock at least once per year.

High velocity air exhaust will decrease the operating efficiency of the electrostatic system. Air exhaust velocity of 100 ft/min (31 linear meters/minute) should be sufficient.





Air Supply Line

				
<p>To reduce the risk of electric shock, the air supply hose must be electrically connected to a true earth ground. Use only Graco Grounded Air Supply Hose.</p>				

1. See Fig. 10. Use the Graco Grounded Air Supply Hose (AH) to supply air to the gun. The gun air inlet fitting has a left-hand thread. The air supply hose ground wire (AG) must be connected to a true earth ground. Do not connect the air supply hose to the gun air inlet yet.
2. Install an air line filter/water separator (AF) on the gun air line to ensure a dry, clean air supply to the gun. Dirt and moisture can ruin the appearance of your finished workpiece and can cause the gun to malfunction.

				
<p>To reduce the risk of serious injury due to component rupture, including skin injection, pump pressure must be limited by the pump air regulator. Do not rely on the gun fluid regulator to limit the fluid pressure to the gun.</p> <p>The fluid supply pump must be prevented from producing a fluid pressure greater than the 3000 psi (21 MPa, 210 bar) <i>Maximum Working Fluid Pressure</i> of the gun. For example, the air supply pressure to a 30:1 ratio pump must not exceed 100 psi (0.7 MPa, 7 bar).</p>				

3. Install bleed-type air regulators (PR, GR) on the pump and gun air supply lines to control air pressure to the pump and gun.

				
<p>Trapped air can cause the pump to cycle unexpectedly, which can result in serious injury, including skin injection and splashing fluid in the eyes or on the skin. Do not operate the equipment without the bleed-type air valve (BV) installed.</p>				

4. Install a bleed-type air valve (BV) on the pump air supply line. The bleed-type air valve (BV) is required in your system to shut off air to the pump and relieve air trapped between the valve and the pump after the air regulator is shut off. Install an additional bleed-type air valve on the main air line (MA) to isolate the accessories for servicing.
5. Install an air bleed valve (BV) on each gun air supply line to shut off air to the gun(s) and relieve air trapped between the valve and the gun after the air regulator is shut off.

Fluid Supply Line

1. Blow out the fluid line (FL) with air and flush it with solvent. Use solvent which is compatible with the fluid to be sprayed. Do not connect the fluid supply line to the gun fluid inlet yet.
2. Install a fluid pressure regulator (FR) on the fluid line to control fluid pressure to the gun.
3. Install a fluid filter (FF) near the pump outlet, to remove particles and sediment which could clog the spray nozzle.

NOTE: The gun includes an inline fluid filter for additional filtration.

				
<p>To reduce the risk of serious injury, including skin injection and splashing fluid in the eyes or on the skin, do not operate equipment without the fluid drain valve (FD) installed.</p>				

4. The fluid drain valve (FD) is required in your system to assist in relieving fluid pressure in the displacement pump, hose, and gun. Triggering the gun to relieve pressure may not be sufficient. Install a drain valve close to the pump's fluid outlet.

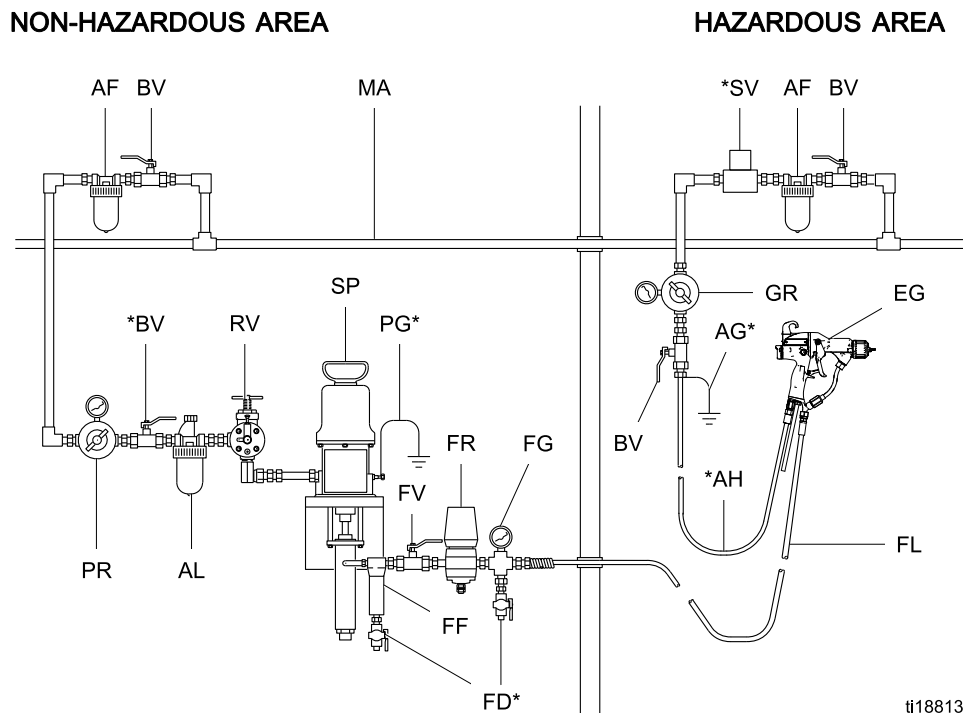

ti18813a

Figure 10 Typical Installation

Typical Installation Key

Item	Description
AF	Air Filter/Water Separator
AG*	Gun Air Hose Ground Wire
AH*	Graco Grounded Air Hose (left-hand threads)
AL	Pump Air Line Lubricator
BV*	Pump Bleed-Type Air Shutoff Valve
EG	Electrostatic Air Spray Gun
FD*	Fluid Drain Valve
FF	Fluid Filter
FG	Fluid Pressure Gauge
FL	Fluid Supply Line
FR	Fluid Pressure Regulator

Item	Description
FV	Fluid Shutoff Valve
GR	Gun Air Pressure Regulator
MA	Main Air Supply Line
PG*	Pump Ground Wire
PR	Pump Air Pressure Regulator
RV	Pump Runaway Valve
SP	Supply Pump
SV*	Ventilation Fan Interlock Solenoid Valve NOTE: The solenoid valve is not offered as a Graco accessory.

* These items are required for safe operation. They must be purchased separately.

Gun Setup

Gun Setup Checklist

See Fig. 11 to locate the electrostatic gun controls.

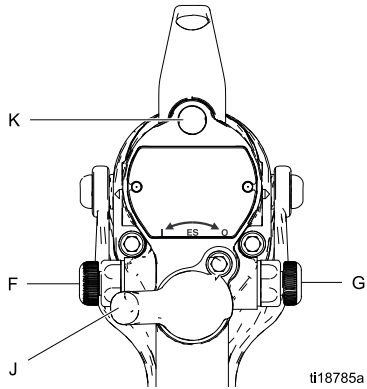
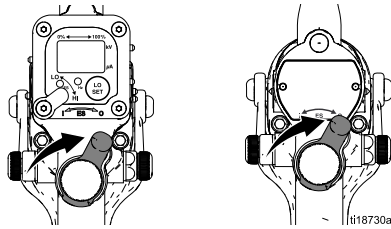
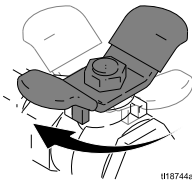

Figure 11 Electrostatic Gun Controls

1. Turn OFF (O) the ES On-Off switch (J).



2. Shut off the air bleed valve to the gun.



3. Check gun resistance. See [Test Gun Resistance, page 32](#).

4. Connect the Graco grounded air hose to the gun air inlet. The gun air inlet fitting has left-hand threads.

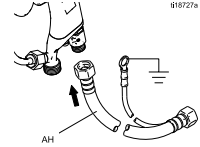

5. Follow all steps under [Grounding, page 21](#).
6. Follow all steps under [Check Gun Electrical Grounding, page 25](#). Reading must be less than 1 megohm.

7. Verify that the material resistivity meets requirements for electrostatic spray. See [Check Fluid Resistivity, page 26](#).





8. Connect the exhaust tube and secure with the clamp provided.

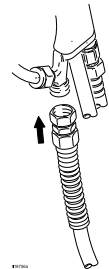

9. Connect the fluid hose to the gun fluid inlet.



10. Flush if needed. See [Flushing, page 28](#).

				
<p>To reduce the risk of a skin injection injury, always follow the Pressure Relief Procedure, page 27, before removing or installing the spray tip, air cap, or tip guard.</p>				

- 11. The fluid output and pattern width depend on the size of the spray tip, the fluid viscosity, and the fluid pressure. Use the [Spray Tip Selection Chart, page 62](#), as a guide for selecting the appropriate spray tip for your application.
- 12. Align the spray tip tab with the groove in the air cap. Install the tip.

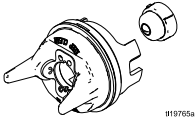

- 13. Install the air cap and retaining ring. Orientate the air cap and tighten the retaining ring securely.

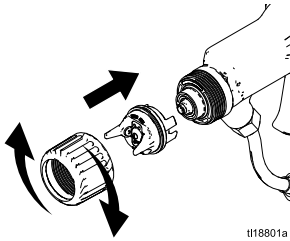

- 14. Close the atomizing air adjustment valve (G) and the fan air adjustment valve (F).

- 15. Check that the ES On-Off switch is OFF (O).

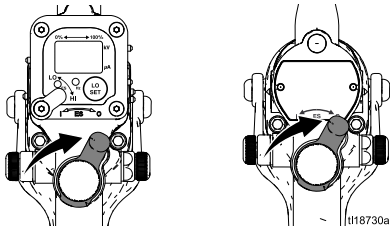

- 16. Start the pump. Set the fluid regulator to 400 psi (2.8 MPa, 28 bar).
- 17. Spray a test pattern. Examine the particle size in the center of the pattern (tails will be removed in step 21). Increase the pressure in small increments. Spray another pattern. Compare particle size. Continue increasing pressure until the particle size remains constant. Do not exceed 3000 psi (21 MPa, 210 bar).

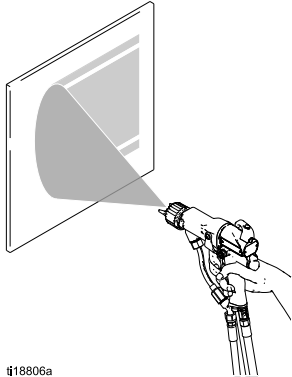

- 18. Turn ON (I) the ES On-Off switch.

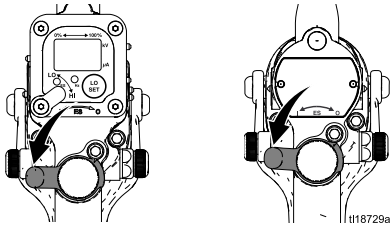

Gun Setup

19. Check that the ES indicator (K) [Hz indicator on Smart guns] is lit. See the following table.

Table 2 . LED Indicator Colors

Indicator Color	Description
Green	When spraying, the indicator should remain green, indicating sufficient air pressure to the alternator turbine.
Amber	If the indicator changes to amber after 1 second, the air pressure is too low. Increase air pressure until the indicator is green.
Red	If the indicator changes to red after 1 second, the air pressure is too high. Decrease air pressure until the indicator is green. If you want to maintain a higher application air pressure, install ES On/Off Valve Restrictor Kit 26A294. Then, adjust the pressure as needed to ensure operation in the green light.

20. Set the gun air regulator to deliver a minimum of 45 psi (0.32 MPa, 3.2 bar) at the gun when triggered, to ensure full spraying voltage. See the table below.



Table 3 . Pressure Drop

Air Hose Length in ft (m) (using 5/16 in. [8 mm] diameter hose)	Air Regulator Setting in psi (MPa, bar) [with gun triggered]
15 (4.6)	52 (0.36, 3.6)
25 (7.6)	57 (0.40, 4.0)
50 (15.3)	68 (0.47, 4.7)
75 (22.9)	80 (0.56, 5.6)
100 (30.5)	90 (0.63, 6.3)

21. Turn the atomizing air adjustment valve counterclockwise until any tails disappear.

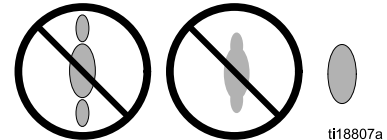
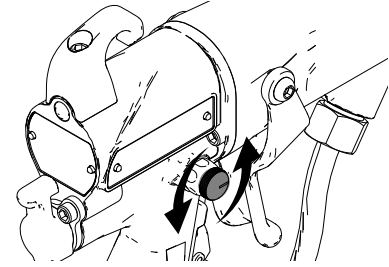

ti18807a



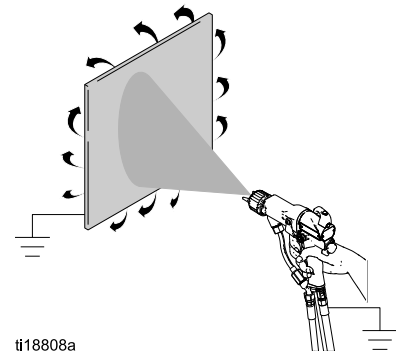

22. If desired atomization is not achieved, change the tip size. The smaller the tip orifice, the finer the atomization.
23. Spray a test piece. Examine the edges for coverage. If wrap is poor, see [Troubleshooting, page 35](#).



ti18808a

NOTE: If a narrower pattern is needed occasionally, open the fan air adjustment valve slightly. (Excessive fan air flow can cause paint buildup on the air cap.)

Grounding

				
<p>When operating the electrostatic gun, any ungrounded objects in the spray area (people, containers, tools, etc.) can become electrically charged. Improper grounding can result in static sparking, which can cause a fire, explosion, or electric shock. Ground all equipment, personnel, object being sprayed, and conductive objects in or close to the spray area. Resistance must not exceed 1 megohm. Follow the grounding instructions below.</p>				

The following are minimum grounding requirements for a basic electrostatic system (see Figs. 12–15). Your system may include other equipment or objects which must be grounded. Check your local electrical code for detailed grounding instructions. Your system must be connected to a true earth ground.

- *Pump/fluid source:* ground the pump/fluid source by connecting its ground wire to a true earth ground.

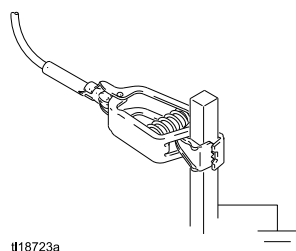

- *Electrostatic Air-Assisted Spray Gun:* ground the gun by connecting the Graco Grounded Air Hose to the gun, and connecting the air hose ground wire to a true earth ground. See [Check Gun Electrical Grounding, page 25](#).

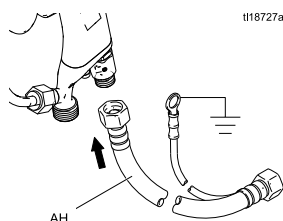

- *Object being sprayed:* keep the workpiece hangers clean and grounded at all times.

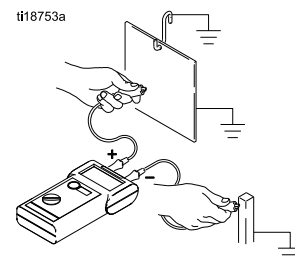

- *All electrically conductive objects or devices in the spray area:* must be properly grounded.

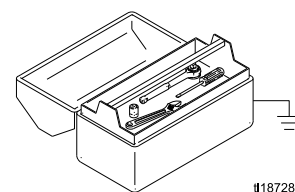

- *Fluid and waste containers:* ground all fluid and waste containers in the spray area. Do not use pail liners unless they are conductive and grounded. When flushing the spray gun, the container used to catch the excess fluid must be electrically conductive and grounded.
- *Air compressors:* ground the equipment according to the manufacturer's recommendations.
- *All air and fluid lines* must be properly grounded. Use only grounded hoses with a maximum of 100 feet (30.5 m) combined hose length to ensure grounding continuity

Gun Setup

- *The floor of the spray area:* must be electrically conductive and grounded. Do not cover the floor with cardboard or any non-conductive material which would interrupt grounding continuity

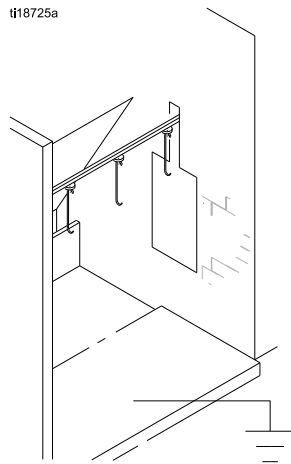

- *Flammable liquids in the spray area:* must be kept in approved, grounded containers. Do not use plastic containers. Do not store more than the quantity needed for one shift.

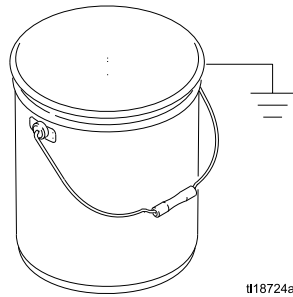

- *All persons entering the spray area:* must wear shoes having conductive soles such as leather, or wear personal grounding straps. Do not wear shoes with non-conductive soles such as rubber or plastic. If gloves are necessary, wear the conductive gloves supplied with the gun. If non-Graco gloves are worn, cut off fingers or palm area of gloves to ensure your hand contacts the grounded gun handle. Conductive gloves and footwear must not exceed 100 megohm per EN ISO 20344, EN 1149-5.

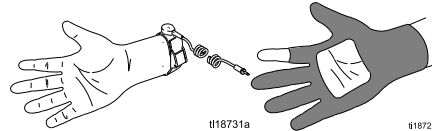

Key to Figs. 12–15

Fig. 12	Operator is grounded through the gun handle and conductive shoes.
Fig. 13	Object being sprayed is grounded through contact with the hanger and conveyor system.
Fig. 14	Gun is grounded through the conductive air hose.
Fig. 15	Fluid supply line and source must be grounded.

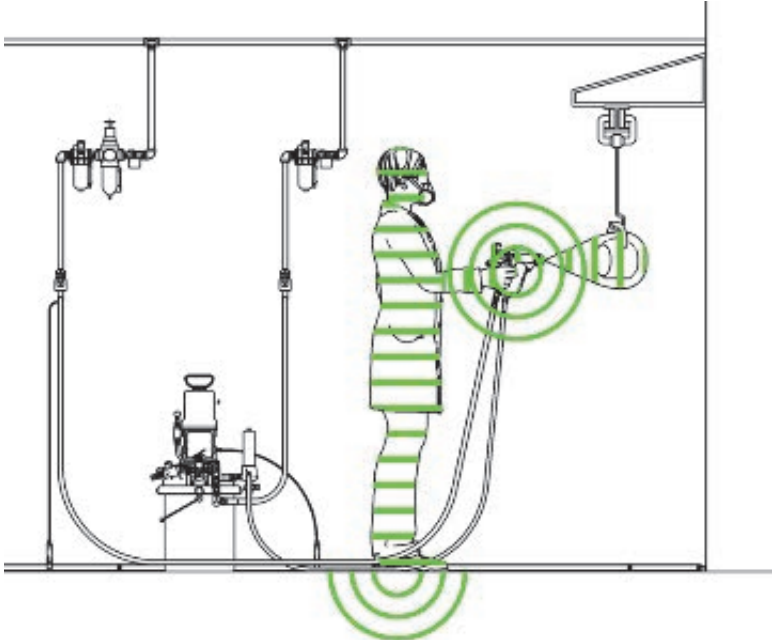

Figure 12 Ground the Operator

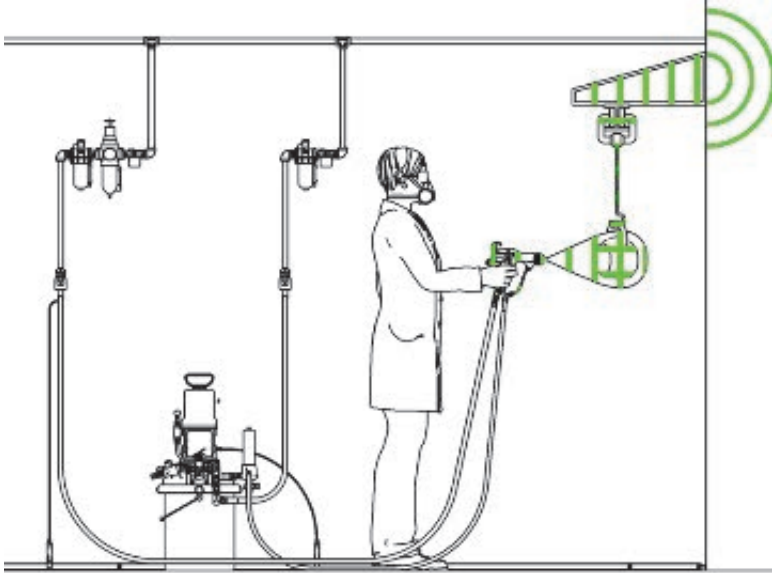

Figure 13 Ground the Object being Sprayed

Gun Setup

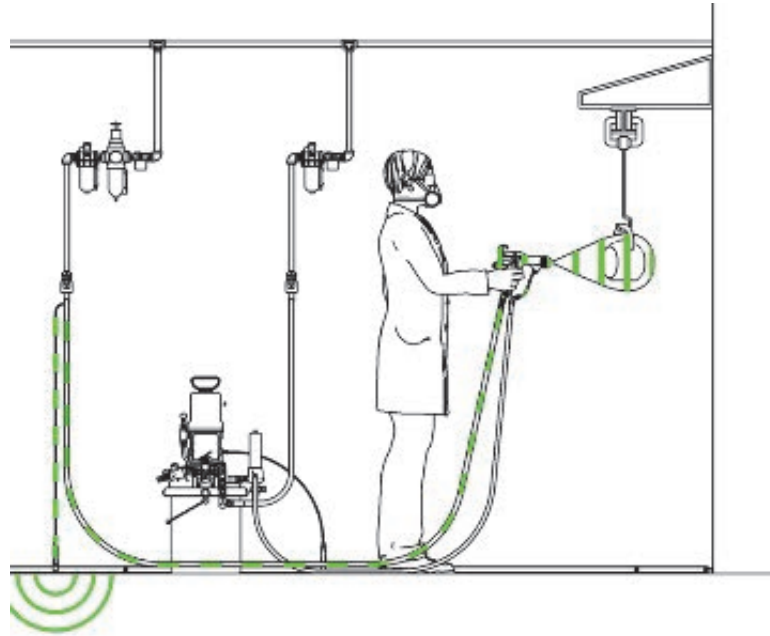

Figure 14 Ground the Gun

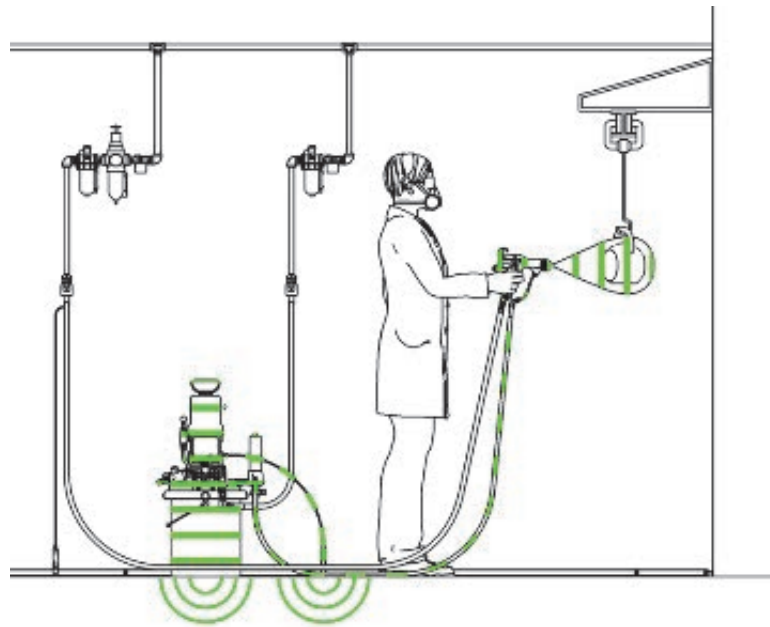





Figure 15 Ground the Fluid Supply

Check Gun Electrical Grounding

				
---	---	---	--	--

Megohmmeter Part No. 241079 (AA-see Fig. 16) is not approved for use in a hazardous area. To reduce the risk of sparking, do not use the megohmmeter to check electrical grounding unless:

- The gun has been removed from the hazardous area;
- Or all spraying devices in the hazardous area are turned off, ventilation fans in the hazardous area are operating, and there are no flammable vapors in the area (such as open solvent containers or fumes from spraying).

Failure to follow this warning could cause fire, explosion, and electric shock and result in serious injury and property damage.

Graco Part No. 241079 Megohmmeter is available as an accessory to check that the gun is properly grounded.

1. Have a qualified electrician check the electrical grounding continuity of the spray gun and air hose.
2. Turn OFF (O) the ES On-Off switch.

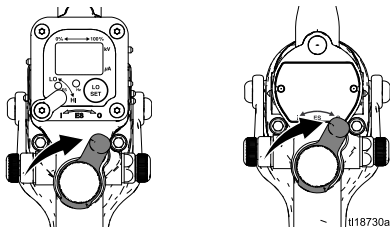

3. Turn off the air and fluid supply to the gun. Follow the [Pressure Relief Procedure, page 27](#).
4. Disconnect the fluid hose.

5. Make sure the grounded air hose is connected and the hose ground wire is connected to a true earth ground.

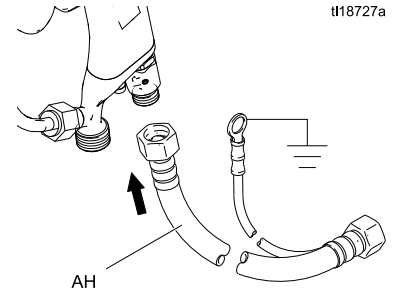

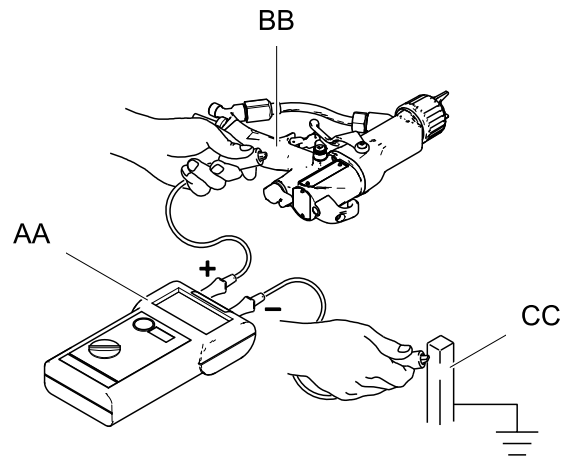

6. Measure the resistance between the gun handle (BB) and a true earth ground (CC). Use an applied voltage of 500 minimum to 1000 volts maximum. The resistance should not exceed 1 megohm. See Fig. 16.
7. If the resistance is greater than 1 megohm, check the tightness of the ground connections and be sure the air hose ground wire is connected to a true earth ground. If the resistance is still too high, replace the air hose.



ti18787a
Figure 16 Check Gun Electrical Grounding

Check Fluid Resistivity

				
<p>To reduce the risk of fire, explosion, or electric shock, check the fluid resistivity in a non-hazardous area only. Resistance Meter 722886 and Probe 722860 are not approved for use in a hazardous area.</p> <p>Failure to follow this warning could cause fire, explosion, or electric shock and result in serious injury and property damage.</p>				

Graco Part No. 722886 Resistance Meter and 722860 Probe are available as accessories to check that the resistivity of the fluid being sprayed meets the requirements of an electrostatic air-assisted spray system.

Follow the instructions included with the meter and probe. Readings of 20 megohms-cm and above provide the best electrostatic results and are recommended.

Table 4 . Fluid Resistivity Levels

Megohms-cm			
1-5	5-20	20-200	200-2000
Test electrostatic performance	Good electrostatic results	Best electrostatic results	Good electrostatic results

Check Fluid Viscosity

To check fluid viscosity you will need:





- a viscosity cup
 - a stopwatch.
1. Completely submerge the viscosity cup in the fluid. Lift the cup out quickly, starting the stopwatch as soon as the cup is completely removed.
 2. Watch the stream of fluid coming from the bottom of the cup. As soon as there is a break in the stream, shut off the stopwatch.
 3. Record the fluid type, elapsed time, and size of the viscosity cup.
 4. If the viscosity is too high or too low, contact the material supplier. Adjust as necessary.

Flush Before Using Equipment

The equipment was tested in fluid at the factory. To avoid contaminating your fluid, flush the equipment with a compatible solvent before using the equipment.

Operation

Pressure Relief Procedure

				
<p>This equipment stays pressurized until pressure is manually relieved. To help prevent serious injury from pressurized fluid, such as skin injection, splashing fluid and moving parts, follow the Pressure Relief Procedure when you stop spraying and before cleaning, checking, or servicing the equipment.</p>				

1. Turn OFF (O) the ES On/Off switch.

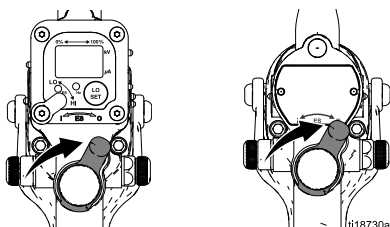

2. Engage the trigger lock.

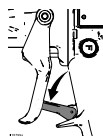

3. Turn off the air bleed valves to the fluid source and to the gun.



4. Disengage the trigger lock.

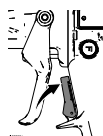

5. Trigger the gun into a grounded metal waste container to relieve the fluid pressure.

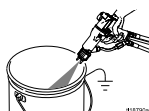

6. Engage the trigger lock.

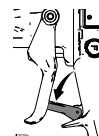

7. Open the pump drain valve, having a waste container ready to catch the drainage. Leave the pump drain valve open until you are ready to spray again.

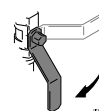

8. If the spray tip or hose is completely clogged or pressure is not fully relieved, slowly loosen the hose end coupling. Now clear the spray tip or hose.

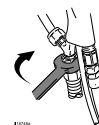

Startup

Follow all steps under [Gun Setup Checklist](#), page 18.

Shutdown



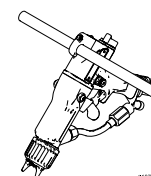

1. Flush the gun. See [Flushing](#), page 28.
2. Follow the [Pressure Relief Procedure](#), page 27.
3. Hang the gun from its hook, with the nozzle pointing down.



Maintenance

Flushing

- Flush before changing fluids, before fluid can dry in the equipment, at the end of the day, before storing, and before repairing equipment.
- Flush at the lowest pressure possible. Check connectors for leaks and tighten as necessary.
- Flush with a fluid that is compatible with the fluid being dispensed and the equipment wetted parts.

				
<p>To avoid fire, explosion, and electric shock:</p> <ul style="list-style-type: none"> • Turn OFF (O) the ES On-Off switch before flushing the gun. • Always ground equipment and waste container. • Flush equipment only in a well-ventilated area. • Use only Group IIA flushing materials. Non-ignitable fluids are preferred. • To avoid static sparking and injury from splashing, always flush at the lowest possible pressure. 				

NOTICE
<p>Do not use methylene chloride as a flushing or cleaning solvent with this gun as it will damage nylon components.</p>

1. Turn OFF (O) the ES On-Off switch.

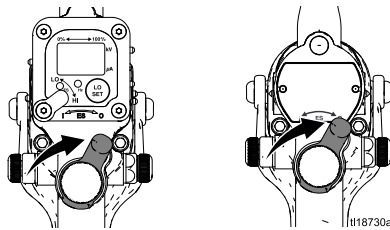

2. Follow the [Pressure Relief Procedure, page 27](#).
3. Remove and clean the air cap and spray tip.

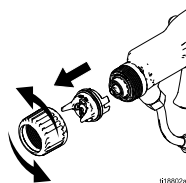

4. Change the fluid source to solvent, or disconnect the fluid line and connect a solvent supply line to the gun.
5. Point the gun into a grounded metal pail. Flush until clean solvent flows from the gun.

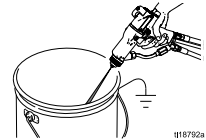

6. Follow the [Pressure Relief Procedure, page 27](#). Engage the trigger lock.

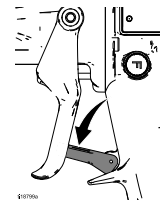

7. Shut off or disconnect the solvent line.
8. Align the spray tip tab with the groove in the air cap. Check the condition of the tip gasket (27a), and replace if damaged. Install the tip.

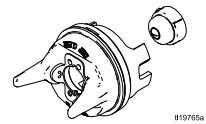

9. Reinstall the air cap, tip guard, and retaining ring.

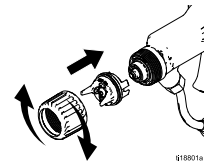

10. Hang the gun from its hook, with the nozzle pointing down.

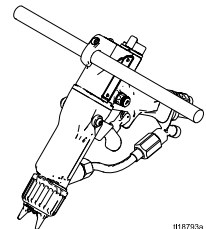

11. When ready to spray again, reconnect the fluid supply line. Follow the [Gun Setup Checklist, page 18](#).

Clean the Gun Daily

1. Turn OFF (O) the ES On-Off switch.

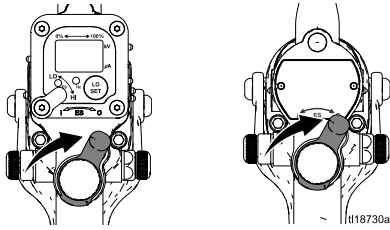

2. Follow the [Pressure Relief Procedure](#), page 27.
3. Remove the air cap/tip guard and spray tip.

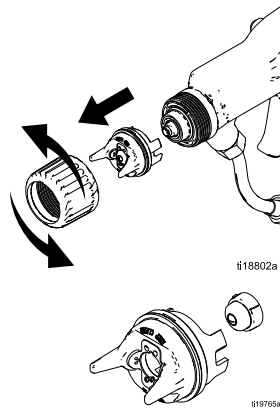

4. Flush the gun, see [Flushing](#), page 28.
5. Follow the [Pressure Relief Procedure](#), page 27.

6. Clean the outside of the gun with a compatible solvent. Use a soft cloth. Point the gun down to prevent solvent from entering the gun passages. Do not immerse the gun.

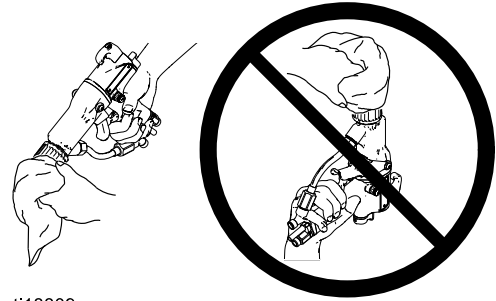

Maintenance

7. Clean the air cap/tip guard and spray tip with a soft brush and compatible solvent.

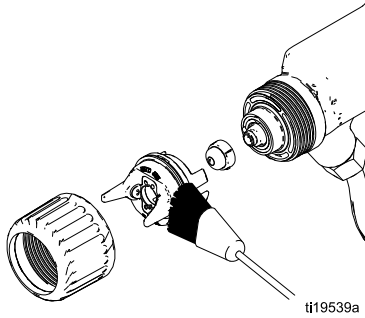

8. If necessary, use a toothpick or other soft tool to clean the air cap holes. Do not use metal tools.



9. Align the spray tip tab with the groove in the air cap. Check the condition of the tip gasket (27a), and replace if damaged. Install the tip.

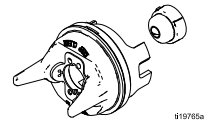

10. Install the air cap and retaining ring. Orientate the air cap and tighten the retaining ring securely.

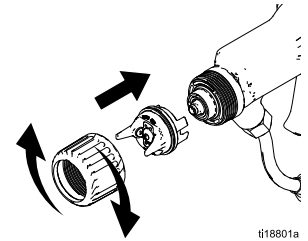

Daily System Care

1. Follow the instructions under [Clean the Gun Daily, page 29](#). Follow the [Pressure Relief Procedure, page 27](#).
2. Clean the fluid and air filters.

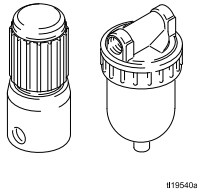

3. Check for fluid leaks. Tighten all fittings.

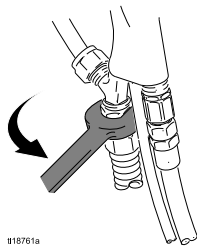

4. Clean workpiece hangers. Use non-sparking tools.

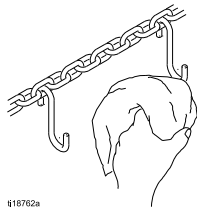

5. Check the movement of the trigger and valves. Lubricate if necessary.

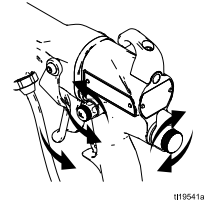

6. [Check Gun Electrical Grounding, page 25](#).
7. Hang the gun from its hook, with the nozzle pointing down.

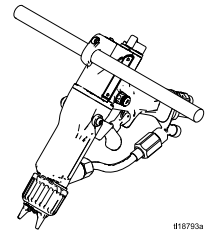

Electrical Tests

Use the following procedures to test the condition of the power supply and gun body, and electrical continuity between components.

NOTICE

The gun body resistor cartridge is part of the body and is not replaceable. To avoid destroying the gun body, do not attempt to remove the body resistor.

Use megohmmeter Part No. 241079 (AA) with an applied voltage of 500 V. Connect the leads as shown.

				
---	---	---	--	--

Megohmmeter Part No. 241079 (AA-see Fig. 17) is not approved for use in a hazardous area. To reduce the risk of sparking, do not use the megohmmeter to check electrical grounding unless:

- The gun has been removed from the hazardous area;
- Or all spraying devices in the hazardous area are turned off, ventilation fans in the hazardous area are operating, and there are no flammable vapors in the area (such as open solvent containers or fumes from spraying).

Failure to follow this warning could cause fire, explosion, and electric shock and result in serious injury and property damage.

Test Gun Resistance

1. Flush and dry the fluid passage.
2. Measure resistance between the electrode needle tip (25a) and the air swivel (21). The resistance should be:
 - 106–150 megohms for 60 kV guns
 - 150–195 megohms for 85 kV guns

If outside this range, go to [Test Power Supply Resistance, page 33](#). If in range, see [Electrical Troubleshooting, page 37](#) for other possible causes of poor performance.

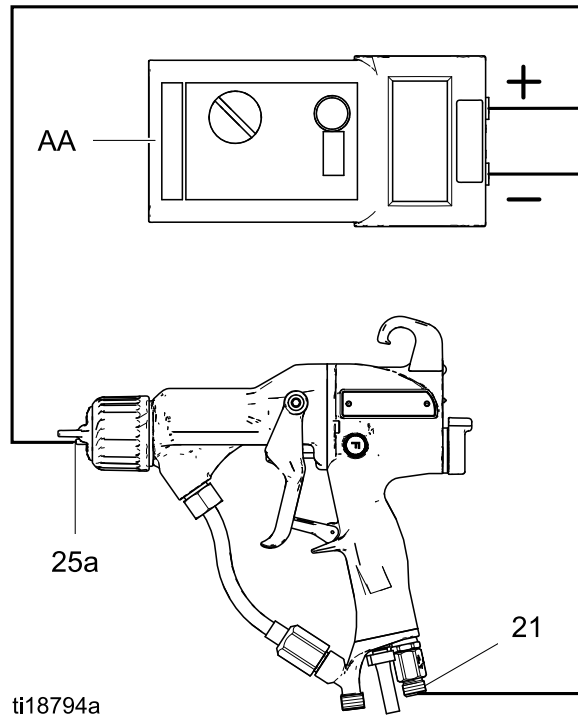

ti18794a
Figure 17 Test Gun Resistance

Test Power Supply Resistance

1. Remove the power supply (11). See [Power Supply Removal and Replacement, page 45](#).
2. Remove the alternator (15) from the power supply. See [Alternator Removal and Replacement, page 46](#).
3. Measure resistance from the power supply's ground strips (EE) to the spring (11a). The resistance should be:
 - 86–110 megohms for 60kV guns
 - 130–160 megohms for 85kV guns
4. If outside this range, replace the power supply. If in range, go to [Test Gun Barrel Resistance, page 34](#).
5. If you still have problems, refer to [Electrical Troubleshooting, page 37](#), for other possible causes of poor performance, or contact your Graco distributor.
6. Be sure the spring (11a) is in place before reinstalling the power supply.

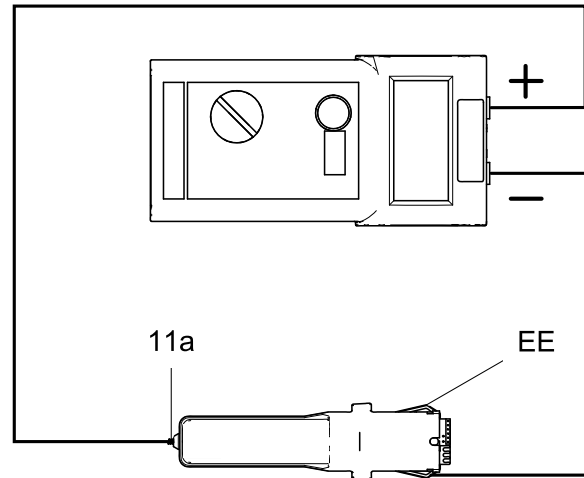

ti18735a

Figure 18 Test Power Supply Resistance

Test Gun Barrel Resistance

1. Insert a conductive rod (B) into the gun barrel (which was removed for the power supply test) and against the metal contact (C) in the front of the barrel.
2. Measure the resistance between the conductive rod (B) and the conductive ring (9). The resistance should be 10–30 megohms. If the resistance is incorrect, make sure the metal contact (C) in the barrel and the conductive ring (9) are clean and undamaged.
3. If the resistance is still outside the range, remove the conductive ring (9) and measure the resistance between the conductive rod (B) and the wire lead at the bottom of the conductive ring groove.
4. If the resistance is in range, replace the conductive ring (9) with a new one. Insert the ends of the conductive ring into the slots (S) at the front of the barrel, then press the ring firmly into the groove (G).

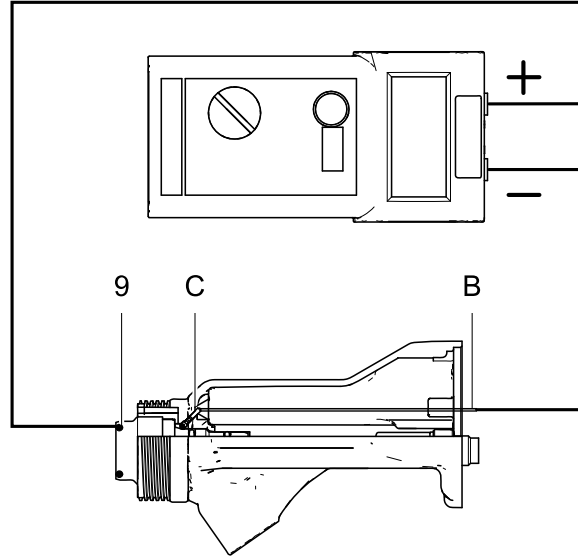

ti19544a

Figure 19 Test Gun Barrel Resistance

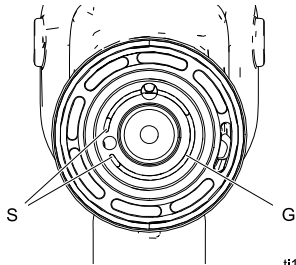







ti19901a

<p>The conductive ring (9) is a conductive (metal) contact ring, not a sealing o-ring. To reduce the risk of fire, explosion, or electric shock:</p> <ul style="list-style-type: none"> • Do not remove the conductive ring except to replace it. • Never operate the gun without the conductive ring in place. • Do not replace the conductive ring with anything but a genuine Graco part. 				

5. If the resistance is still outside the range, replace the gun barrel.

Troubleshooting



				
<p>Installing and servicing this equipment requires access to parts which may cause an electric shock or other serious injury if the work is not performed properly. Do not install or service this equipment unless you are trained and qualified.</p>				

				
<p>To reduce the risk of a skin injection injury, always follow the Pressure Relief Procedure, page 27, whenever you are instructed to relieve the pressure.</p>				

NOTE: Check all possible remedies in the Troubleshooting Chart before disassembling the gun.

Spray Pattern Troubleshooting

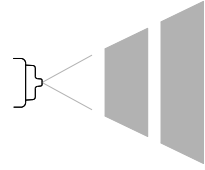
NOTE: Some spray pattern problems are caused by the improper balance between air and fluid.

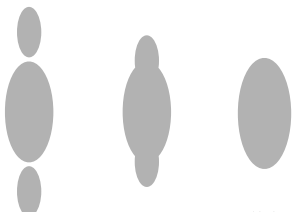
Problem	Cause	Solution
Fluttering or spitting spray. 	No fluid.	Refill supply.
	Air in fluid supply.	Check fluid source. Refill.
Irregular pattern.  ii18798a	Fluid buildup; partially plugged tip.	Clean. See Clean the Gun Daily, page 29 .
	Worn/damaged tip or air cap holes.	Clean or replace.
Pattern pushed to one side; air cap gets dirty.	Air cap holes plugged.	Clean. See Clean the Gun Daily, page 29 .
Tails in pattern.  ii18797a	Air pressure too low.	Open atomizing air adjustment valve.
	Fluid pressure too low.	Increase.
Fluid buildup on air cap/tip guard.	Air pressure too high.	Decrease.
	Fluid pressure too low.	Increase.
	Air cap holes plugged.	Clean. See Clean the Gun Daily, page 29 .

Gun Operation Troubleshooting

Problem	Cause	Solution
Excessive spray fog.	Atomizing air pressure too high.	Close atomizing air valve part way, or decrease air pressure as low as possible; minimum 45 psi (0.32 MPa, 3.2 bar) needed at gun for full voltage.
	Fluid too thin.	Increase viscosity or increase fluid flow rate.
"Orange Peel" finish.	Atomizing air pressure too low.	Open atomizing air valve more or increase gun air inlet pressure; use lowest air pressure necessary.
	Spray tip is too large.	Use smaller tip. See Spray Tip Selection Chart, page 62 .
	Poorly mixed or filtered fluid.	Remix or refill fluid.
	Fluid too thick.	Reduce viscosity.
Fluid leaks from the fluid packing area.	Worn fluid needle packings or rod.	See Fluid Needle Replacement, page 44 .
Air leaks from the front of the gun.	Air valve is not seating properly.	See Air Valve Repair, page 51 .
Fluid leakage from the front of the gun.	Worn or damaged fluid needle ball.	See Fluid Needle Replacement, page 44 .
	Worn fluid seat housing.	See Air Cap, Spray Tip, and Fluid Seat Housing Replacement, page 40 .
	Loose spray tip.	Tighten retaining ring.
	Damaged tip seal.	See Air Cap, Spray Tip, and Fluid Seat Housing Replacement, page 40 .
Gun does not spray.	Low fluid supply.	Add fluid if necessary.
	Damaged spray tip.	Replace.
	Dirty or clogged spray tip.	Clean. See Clean the Gun Daily, page 29 .
	Damaged fluid needle.	See Fluid Needle Replacement, page 44 .
Dirty air cap.	Damaged or plugged air cap.	Clean air cap. See Clean the Gun Daily, page 29 .
Excessive paint wrap back to operator.	Poor grounding.	See Grounding, page 21 .
	Incorrect distance from gun to part.	Should be 8–12 in. (200–300 mm).

Electrical Troubleshooting



Problem	Cause	Solution
Poor wrap.	ES On/Off switch is OFF (O).	Turn ON (I).
	Gun air pressure too low (ES indicator is amber).	Check air pressure to gun; minimum 45 psi (0.32 MPa, 3.2 bar) needed at gun for full voltage.
	Atomizing air pressure too high.	Decrease.
	Fluid pressure too high.	Decrease, or replace worn tip.
	Incorrect distance from gun to part.	Should be 8-12 in. (200-300 mm).
	Poorly grounded parts.	Resistance must be 1 megohm or less. Clean workpiece hangers.
	Faulty gun resistance.	See Test Gun Resistance, page 32.
	Low fluid resistivity.	See Check Fluid Resistivity, page 26.
	Fluid leaks from the fluid needle packings and causes a short.	See Fluid Needle Replacement, page 44.
	Faulty alternator.	See Alternator Removal and Replacement, page 46.
ES or Hz indicator is not lit.	ES On/Off switch is OFF (O).	Turn ON (I).
	No power.	Check power supply, alternator, and alternator ribbon cable. See Power Supply Removal and Replacement, page 45 and Alternator Removal and Replacement, page 46.
Operator gets mild shock.	Operator not grounded or is near ungrounded object.	See Grounding, page 21.
	Gun not grounded.	See Check Gun Electrical Grounding, page 25, and Test Gun Resistance, page 32.
Operator gets shock from workpiece.	Workpiece not grounded.	Resistance must be 1 megohm or less. Clean workpiece hangers.





Troubleshooting

Problem	Cause	Solution
Voltage/current display stays red (smart guns only).	Gun is too close to the part being sprayed.	Gun should be 8–12 in. (200–300 mm) from the part.
	Check fluid resistivity.	See Check Fluid Resistivity, page 26.
	Dirty gun.	See Clean the Gun Daily, page 29.
ES or Hz indicator is amber.	Alternator speed is too low.	Increase air pressure until indicator is green. To avoid over-atomization, use the atomizing air restrictor valve to reduce the atomizing air to the air cap.
ES or Hz indicator is red.	Alternator speed is too high.	Decrease air pressure until indicator is green.
Error display appears and Hz indicator is red (Smart guns only).	Smart module has lost communication with the power supply.	Check for good connections between Smart Module and power supply. See Smart Module Replacement, page 52 and Power Supply Removal and Replacement, page 45.

Repair

Prepare the Gun for Service

				
<p>Installing and repairing this equipment requires access to parts that may cause electric shock or other serious injury if the work is not performed properly. Do not install or service this equipment unless you are trained and qualified.</p>				

				
<p>To reduce the risk of injury, follow the Pressure Relief Procedure, page 27, before checking or servicing any part of the system and whenever you are instructed to relieve the pressure.</p>				

- Check all possible remedies in [Troubleshooting, page 35](#), before disassembling the gun.

- Use a vise with padded jaws to prevent damage to plastic parts.
 - Lubricate the some needle assembly parts (20) and certain fluid fittings with dielectric grease (57), as specified in the text.
 - Lightly lubricate o-rings and seals with non-silicone grease. Order Part No. 111265 Lubricant. Do not over-lubricate.
 - Only use genuine Graco parts. Do not mix or use parts from other Pro Gun models.
 - Air Seal Repair Kit 24N789 is available. The kit must be purchased separately. Kit parts are marked with an asterisk, for example (3*).
1. Flush the gun. See [Flushing, page 28](#).
 2. Relieve the pressure. See [Pressure Relief Procedure, page 27](#).
 3. Disconnect the gun air and fluid lines.
 4. Remove the gun from the worksite. Repair area must be clean.

Air Cap, Spray Tip, and Fluid Seat Housing Replacement

1. See [Prepare the Gun for Service, page 39](#).
2. Remove the retainer ring (22) and air cap/tip guard assembly (25).

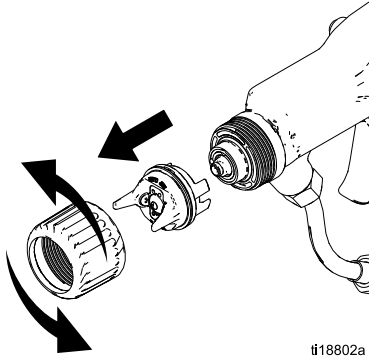

Figure 20 Remove Air Cap

3. Disassemble the air cap assembly. Check the condition of the u-cup (22a), o-ring (25b), and tip gasket (27a). Replace any damaged parts.

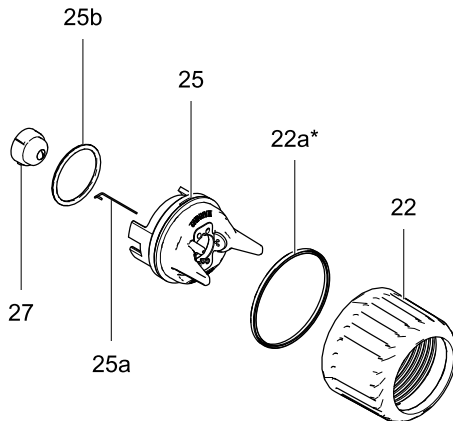

Figure 21 Disassemble Air Cap Assembly

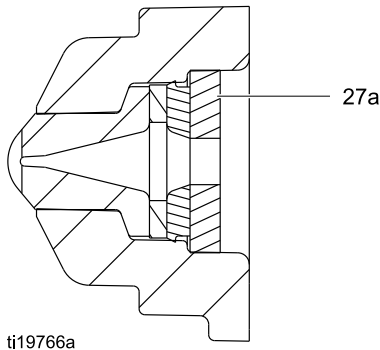

Figure 22 Tip Gasket

4. To replace the electrode (25a), see [Electrode Replacement, page 41](#).

--	--	--	--	--

The conductive ring (9) is a conductive metal contact ring, not a sealing o-ring. To reduce the risk of fire, explosion, or electric shock:

- Do not remove the conductive ring except to replace it.
- Never operate the gun without the conductive ring in place.
- Do not replace the conductive ring with anything but a genuine Graco part.

5. Trigger the gun and remove the fluid seat housing (24), using the multi-tool (61).

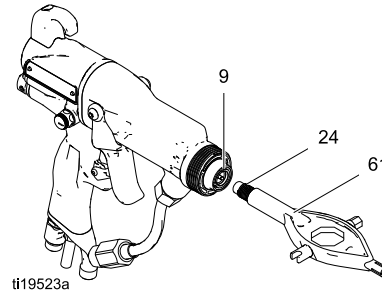

Figure 23 Replace Fluid Seat Housing

NOTICE

Do not overtighten the fluid seat housing (24). Overtightening may damage the housing and the gun barrel, resulting in improper fluid shutoff.

6. Trigger the gun and install the fluid seat housing (24). Tighten until snug, then 1/4 turn more.
7. Check that the spray tip gasket (27a) is in place. Align the spray tip tab with the groove in the air cap (25). Install the spray tip (27) in the air cap.
8. Make sure that the electrode (25a) is installed correctly in the air cap.
9. Check that the air cap o-ring (25b) is in place.
10. Check that the u-cup (22a) is in place on the retaining ring (22). The lips of the u-cup must face forward.

NOTICE

To avoid damaging the tip guard, orient the air cap assembly (25) before tightening the retaining ring (22). Do not turn the air cap when the retaining ring is tight.

11. Orientate the air cap and tighten the retaining ring securely.
12. See [Test Gun Resistance, page 32](#).

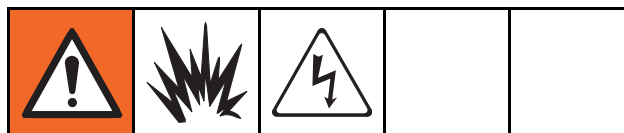
Electrode Replacement

To reduce the risk of fire, explosion, or electric shock, do not operate the spray gun without the electrode installed in the air cap.

1. See [Prepare the Gun for Service, page 39](#).
2. Remove the air cap assembly (25). See [Air Cap, Spray Tip, and Fluid Seat Housing Replacement, page 40](#).
3. Pull the electrode (25a) out of the back of the air cap, using a needle-nose pliers.
4. Push the new electrode through the air cap hole. Make sure the short end (BB) of the electrode engages the hole (CC) in the back of the air cap. Press the electrode in place firmly with your fingers.
5. Install the air cap assembly.
6. See [Test Gun Resistance, page 32](#).

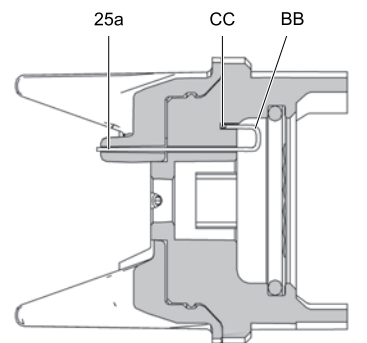

ti19524a

Figure 24 Replace Electrode

Fluid Tube Removal and Replacement

1. See [Prepare the Gun for Service](#), page 39.
2. Disconnect the bottom fluid tube nut (C).
3. Carefully unscrew the top fluid tube nut (D).

NOTICE

Be careful not to damage the fluid tube assembly (19) when cleaning or installing it, especially the sealing surface (E). If the sealing surface is damaged, the entire fluid tube assembly must be replaced.

4. Apply dielectric grease (57) to the entire length of the plastic extension on the fluid tube.
5. Apply low strength sealant to the fluid tube nut threads.
6. Install the fluid tube into the gun barrel and tighten the top nut (D) until snug, then 1/2 turn tighter. There will be a gap between the nut and barrel. Do not over-tighten the nut.
7. Make sure the fluid filter (10) is in place in the fluid fitting. Tighten the bottom nut (C) securely onto the fitting. Make sure the top nut remains tight.

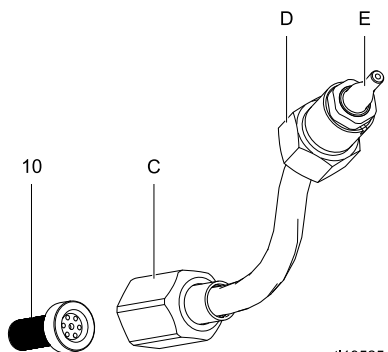

Figure 25 Fluid Tube

Fluid Filter Replacement

1. See [Prepare the Gun for Service](#), page 39.
2. Disconnect the bottom fluid tube nut (C).
3. Remove the fluid filter (10) from the fluid fitting. Clean or replace the filter, as needed.
4. Install the fluid filter (10) in the fluid fitting. Tighten the bottom nut (C) onto the fitting and torque to 140–150 in-lb (15.8–16.9 N•m). Make sure the top nut remains tight at 20–30 in-lb (2.3–3.4 N•m).

NOTICE

Be sure the fluid tube (19) is not twisted after tightening the bottom nut (C).

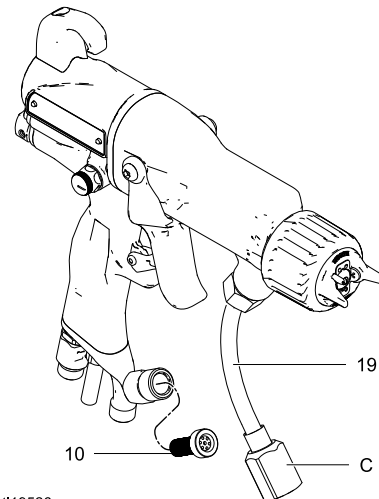

Figure 26 Replace Fluid Filter

Gun Barrel Removal

1. See [Prepare the Gun for Service, page 39](#).
2. Disconnect the bottom fluid tube nut (N). Carefully separate the tube assembly (T) from the bracket (7).
3. Loosen the two screws (6).

NOTICE

To avoid damaging the power supply (11), pull the gun barrel straight away from the gun handle. If necessary, gently move the gun barrel from side to side to free it from the gun handle.

4. Hold the gun handle (16) with one hand and pull the barrel (1) straight off the handle.

NOTE: If the power supply remains in the barrel, remove the alternator/power supply assembly from the barrel.

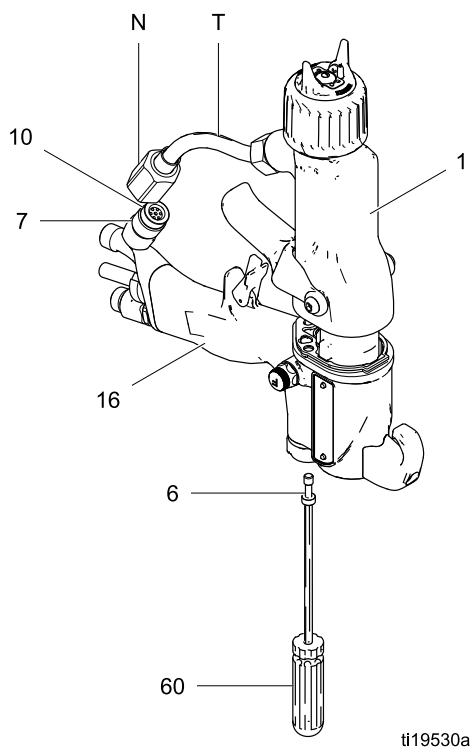

Figure 27 Gun Barrel Removal

Gun Barrel Installation

1. Be sure the gasket (5*) and grounding spring (37a) are in place. Make sure the gasket air holes are aligned properly. Replace the gasket if damaged.
2. Make sure the spring (11a) is in place on the tip of the power supply (11). **Liberal**ly apply dielectric grease (57) to the tip of the power supply. Place the gun barrel (1) over the power supply and onto the gun handle (16).
3. Tighten the two screws (6) oppositely and evenly (about a half turn past snug, or 20 in-lbs, 2.3 N•m). Do not over-tighten the screws (6).
4. Make sure the fluid filter (10) is in place in the fluid fitting. Tighten the bottom nut (N) onto the fitting and torque to 140–150 in-lb (15.8–16.9 N•m). Make sure the top nut remains tight.
5. See [Test Gun Resistance, page 32](#).

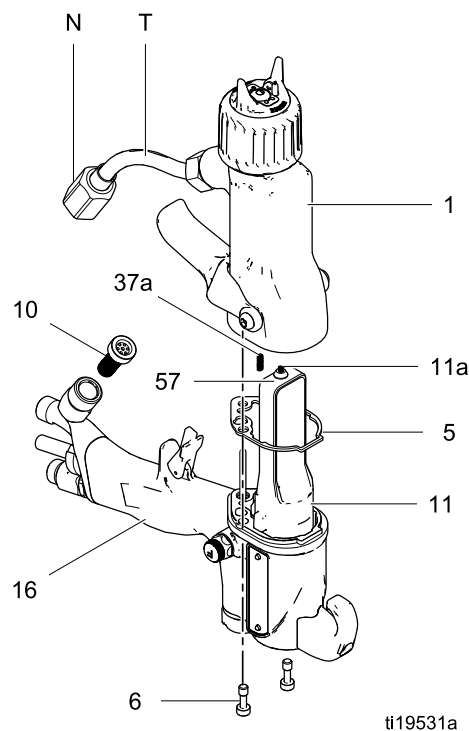

Figure 28 Gun Barrel Installation

Fluid Needle Replacement

1. See [Prepare the Gun for Service, page 39](#).
2. Remove the air cap assembly and fluid seat housing. See [Air Cap, Spray Tip, and Fluid Seat Housing Replacement, page 40](#).
3. Remove the gun barrel. See [Gun Barrel Removal, page 43](#).
4. Remove the trigger screws (13) and trigger (12).
5. Unscrew the spring cap (37). Remove the spring (20a).
6. Be sure the seat housing (24) is removed. Place the 2 mm ball end wrench (60) in the back of the fluid needle assembly. Push the tool forward so the two segments of the needle engage, and turn it counterclockwise about 12 full turns to unthread the needle.
7. Using the external hex end of the plastic multi-tool (61), carefully push straight on the fluid needle ball from the front of the barrel until the fluid seals release from the bore.

NOTICE

To prevent needle assembly separation or damage, be certain needle is disengaged before removing.

8. Remove the fluid needle assembly from the back of the gun barrel.
9. Install the fluid needle assembly in the gun barrel. Push in on the needle with the driver (60) and tighten.
10. Install the spring (20a).
11. Install the spring cap (37). Make sure the grounding spring (37a) is in place.
12. Install the trigger (12) and screws (13).
13. Install the gun barrel. See [Gun Barrel Installation, page 43](#).
14. Install the seat housing and air cap assembly. See [Air Cap, Spray Tip, and Fluid Seat Housing Replacement, page 40](#).
15. See [Test Gun Resistance, page 32](#).

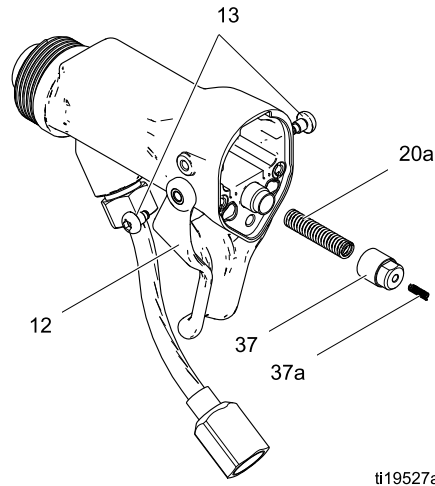

Figure 29 Remove Cap and Springs

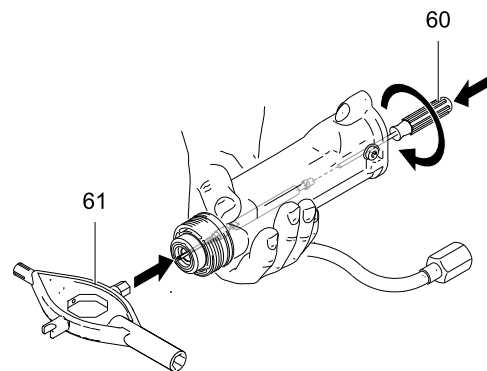

Figure 30 Remove Fluid Needle

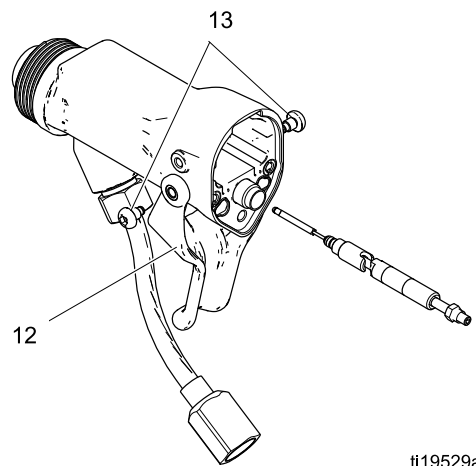

Figure 31 Replace Fluid Needle

Power Supply Removal and Replacement

- Inspect the gun handle power supply cavity for dirt or moisture. Clean with a clean, dry rag.
 - Do not expose gasket (5) to solvents.
1. See [Prepare the Gun for Service, page 39](#).
 2. See [Gun Barrel Removal, page 43](#).

NOTICE

Be careful when handling the power supply (11) to avoid damaging it.

3. Grasp the power supply (11) with your hand. With a gentle side to side motion, free the power supply/alternator assembly from the gun handle (16), then carefully pull it straight out. *On Smart Models only*, disconnect the flexible circuit (40) from the socket at the top of the handle.
4. Inspect the power supply and alternator for damage.
5. To separate the power supply (11) from the alternator (15), disconnect the 3-wire ribbon connector (PC) from the power supply. *On Smart Models only*, disconnect the 6-pin flexible circuit (40) from the power supply. Slide the alternator up and off the power supply.
6. See [Test Power Supply Resistance, page 33](#). Replace the power supply if necessary. To repair the alternator, see [Alternator Removal and Replacement, page 46](#).
7. *Smart models only*: connect the 6-pin flexible circuit (40) to the power supply.

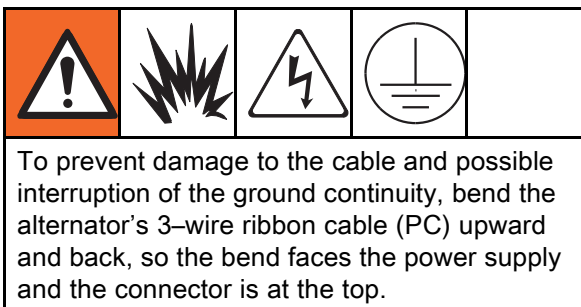

8. Connect the 3-wire ribbon connector (PC) to the power supply. Tuck the ribbon forward, under the power supply. Slide the alternator (15) down onto the power supply (11).

9. Insert the power supply/alternator assembly in the gun handle (16). Make sure the ground strips (EE) make contact with the handle. *On Smart models*, align the connector of the 6-pin flexible circuit (40) with the socket (CS) at the top of the handle. Push the connector securely into the socket as you slide the power supply/alternator assembly into the handle.

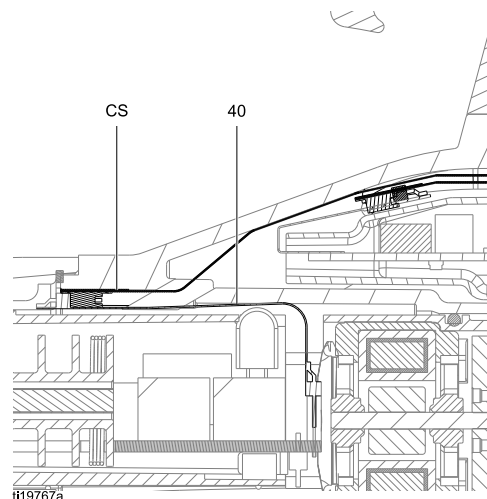

Figure 32 Connect Flexible Circuit

10. Make sure the gasket (5*), ground spring (37a), and power supply spring (11a) are in place. Replace gasket (5*) if damaged. Assemble the barrel (1) to the handle (16). See [Gun Barrel Installation, page 43](#).
11. See [Test Gun Resistance, page 32](#).

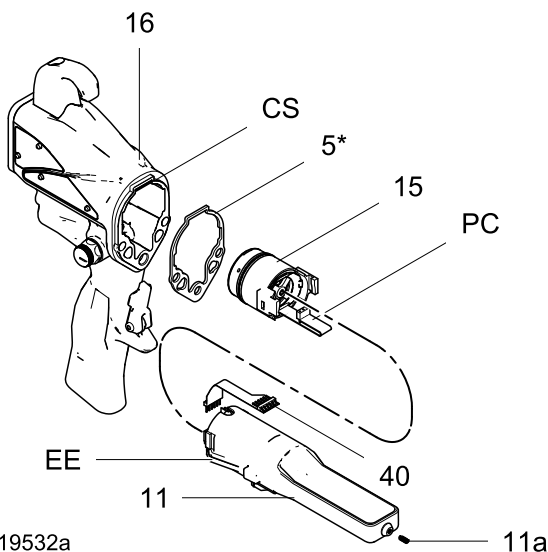

Figure 33 Power Supply

Alternator Removal and Replacement

NOTE: Replace alternator bearings after 2000 hours of operation. Order Part No. 24N706 Bearing Kit. Parts included in the kit are marked with a symbol (◆).

1. See [Prepare the Gun for Service](#), page 39.
2. Remove the power supply/alternator assembly and disconnect the alternator. See [Power Supply Removal and Replacement](#), page 45.
3. Measure resistance between the two outer terminals of the 3-wire connector (PC); it should be 2.0–6.0 ohms. If outside this range, replace the alternator coil (15a).
4. Using a flat blade screwdriver, pry the clip (15h) off the housing (15d). Remove the cap (15f), using a thin blade or screwdriver.
5. If necessary, rotate the fan (15e) so its blades clear the four bearing tabs (T) of the housing (15d).

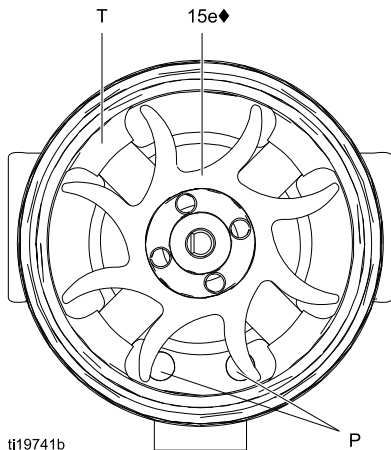

Figure 34 Fan Orientation

6. Push the fan and coil assembly (15a) out the front of the housing (15d).

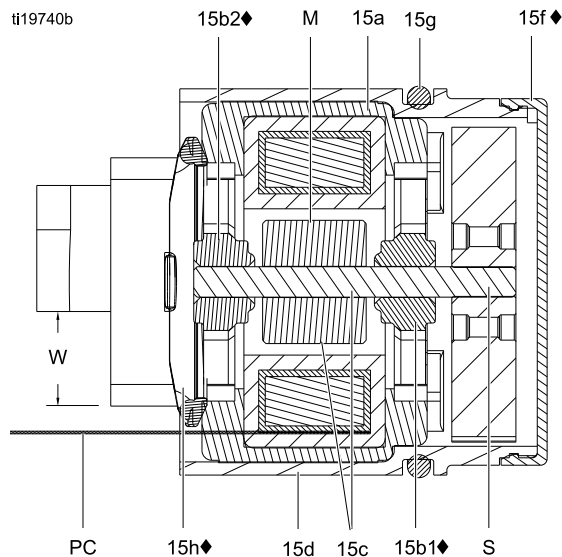

Figure 35 Alternator Cross-Section

◆5 is not shown in the illustration.

NOTICE

Do not scratch or damage the magnet (M) or shaft (S). Do not pinch or damage the 3-wire connector (PC) when disassembling and reassembling the bearings.

7. Hold the coil assembly (15a) on a workbench with the fan end facing up. Using a wide blade screwdriver, pry the fan (15e) off the shaft (S).
8. Remove the top bearing (15b2).
9. Remove the bottom bearing (15b1).
10. Install the new bottom bearing (15b1◆) on the long end of the shaft (S). The flatter side of the bearing must face away from the magnet (M). Install in the coil (15a) so the bearing blades are flush with the surface of the coil.
11. Press the new top bearing (15b2◆) onto the short end of the shaft so the bearing blades are flush with the surface of the coil (15a). The flatter side of the bearing must face away from the coil.

12. Hold the coil assembly (15a) on a workbench with the fan end facing up. Press the fan (15e♦) onto the long end of the shaft (S). The fan blades must be oriented as shown.
13. Carefully press the coil assembly (15a) into the front of the housing (15d♦) while aligning the pin on the coil with the slot in the housing. The 3-wire connector (PC) must be positioned below the wider notch (W) of the housing tabs, as shown in Fig. 35. Be sure the coil alignment pins (P) are positioned as shown in Fig. 34.
14. Rotate the fan (15e) so its blades clear the four bearing tabs (T) at the back of the housing. Ensure that the blades of the bottom bearing (15b1♦) align with the tabs.
15. Seat the coil fully into the housing (15d♦). Secure with the clip (15h♦), ensuring that its tabs engage the slots in the housing.
16. Ensure that the o-ring (15g) is in place. Install the cap (15f).
17. Install the alternator on the power supply, and install both parts in the handle. See [Power Supply Removal and Replacement, page 45](#).

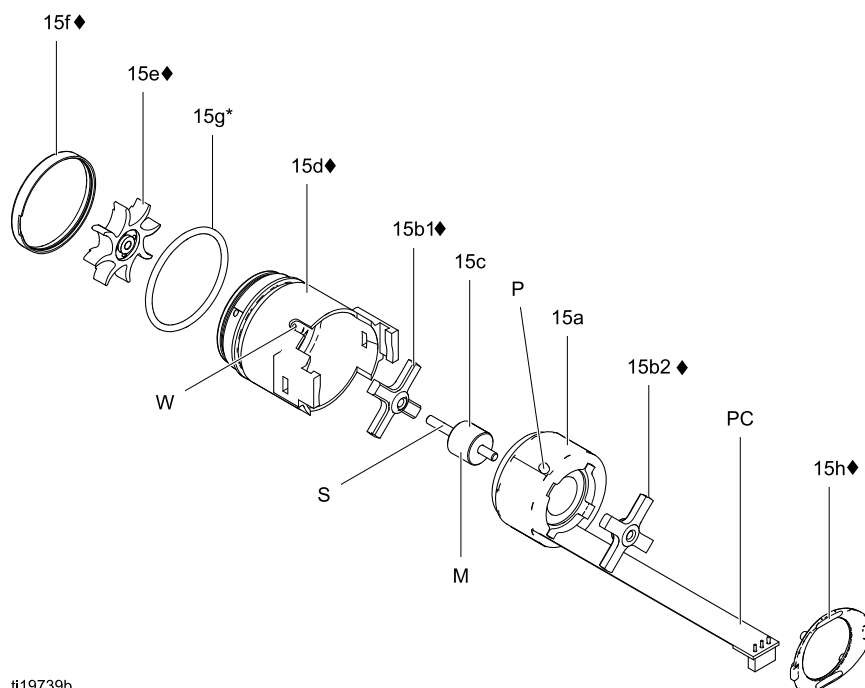

ti19739b

Figure 36 Alternator

Fan Air Adjustment Valve Repair

1. See [Prepare the Gun for Service](#), page 39.
2. Place a wrench on the flats of the valve assembly (30) and unscrew it from the handle (16).

NOTE: You may replace the valve as an assembly (go to step 9) or as individual parts (steps 3-9).

3. Remove the retaining ring (30d).
4. Turn the valve shaft (30b) counterclockwise until it comes free from the valve housing (30a).
5. Remove the o-ring (30c).
6. Clean all parts and inspect for wear or damage.

NOTE: Use non-silicone grease, Part No. 111265. Do not over-lubricate.

7. When reassembling the fan air valve (30), lightly lubricate the valve threads and screw the shaft (30b) fully into the housing (30a) until bottomed. Install the o-ring (30c*), lubricate, and unscrew the valve stem until the o-ring enters the housing.

8. Reassemble the retaining ring (30d). Unscrew the valve stem from the housing until it is stopped by the retaining ring.
9. Screw the valve assembly (30) into the gun handle (16), using a wrench on the flats of the housing. Torque to 15 in-lb (1.7 N•m).

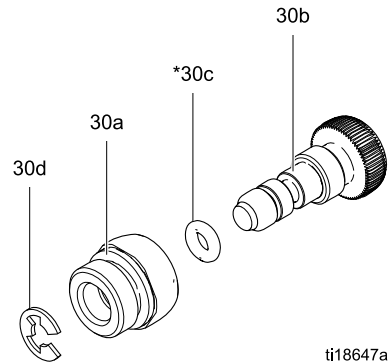

Figure 37 Fan Air Adjustment Valve

Atomizing Air Adjustment Valve Repair

1. See [Prepare the Gun for Service](#), page 39.
2. Place a wrench on the flats of the valve assembly (29) and unscrew it from the handle (16).
3. Inspect the valve assembly. If damaged, install a new valve (29).
4. Before installing the valve assembly in the handle, unscrew the valve stem (29b) from the housing (29a) until it stops.
5. Install the valve assembly into the gun handle. Torque the valve housing (29a) to 15 in-lb (1.7 N•m).

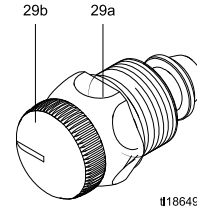

Figure 38 Atomizing Air Adjustment Valve

ES On-Off Valve Repair

1. See [Prepare the Gun for Service](#), page 39.
2. Loosen the captive screw (26p). Remove the valve (26) from the handle.
3. Lubricate the o-rings (26b* and 26g*) with non-silicone grease, Part No. 111265. Do not over-lubricate.

NOTE: Do not over-lubricate parts. Excessive lubricant on the o-rings can be pushed into the gun air passage and blemish the finish on the workpiece.

4. Clean and inspect parts for damage. Replace if necessary.

NOTE: The protrusion on the retainer plate (26f) must point upward.

5. Reinstall the valve. Torque the screw (26p) to 15-25 in-lb (1.7-2.8 N•m).

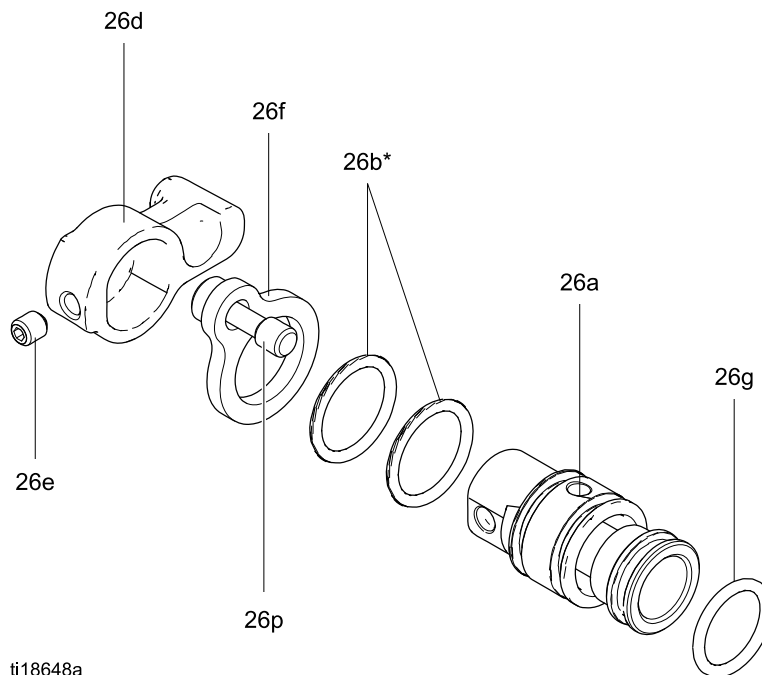
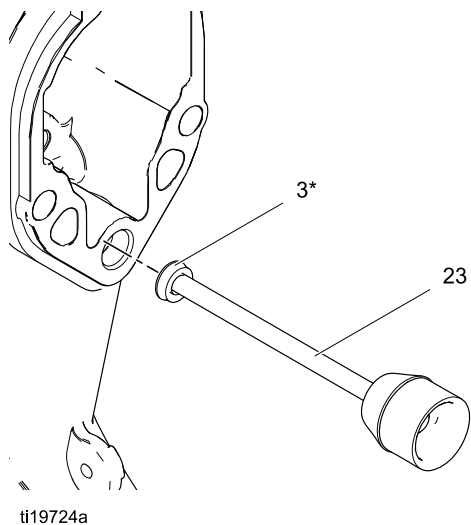

Figure 39 ES On-Off Valve

Air Valve Repair

1. See [Prepare the Gun for Service, page 39](#).
2. See [Gun Barrel Removal, page 43](#).
3. Remove the screws (13) and trigger (12).
4. Remove the ES On-Off Valve. See [ES On-Off Valve Repair, page 50](#).
5. Remove the spring (2).
6. Push on the front of the air valve shaft to force it out the back of the handle. Inspect the rubber seal (23a*) and replace if damaged.
7. Inspect the u-cup (3). Do not remove the u-cup unless damaged. If removed, install the new one with its lips facing into the gun handle (16). Place the u-cup on the shaft of the air valve to help seat it in the gun handle.
8. Install the air valve (23) and spring (2) into the gun handle (16).
9. Install the ES On-Off Valve. See [ES On-Off Valve Repair, page 50](#).
10. Install the trigger (12) and screws (13).
11. See [Gun Barrel Installation, page 43](#).



ti19724a
Figure 40 Install U-Cup

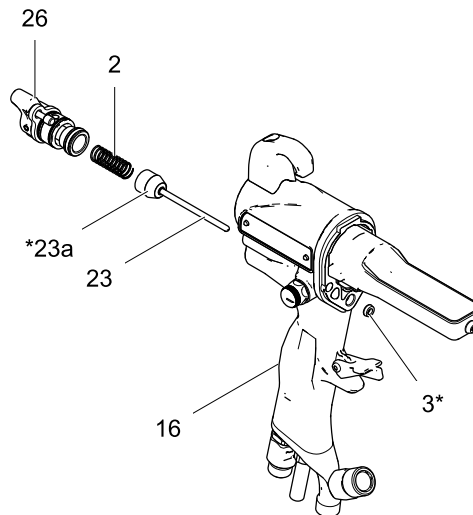

ti19543a
Figure 41 Air Valve

Smart Module Replacement

If the Error display appears, the Smart Module has lost communication with the power supply. Check for good connections between the Smart Module and the power supply.

If the module's LEDs are not lighting, replace the module.

1. See [Prepare the Gun for Service, page 39](#).
2. Remove the pivot screw (31e), o-ring (31f), and ES HI/LO switch (31c) at the bottom left corner of the Smart Module cartridge (31a).
3. Remove the remaining three screws (31d) from the cartridge.
4. Pull the Smart Module out the back of the gun. Disconnect the ribbon cable (RC) from the connector (GC) in the gun handle.
5. Remove the gasket (31b).
6. Install a new gasket (31b) on the new cartridge (31a). Make sure the notched corners of the gasket are at the top.
7. Align the module's ribbon cable (RC) with the gun's cable (GC) and slide them securely together, as shown. Tuck the connected cables into the recess of the gun handle. Install the module flush to the back of the gun handle.
8. Install the pivot screw (31e), o-ring (31f), and ES HI/LO switch in the bottom left corner of the cartridge (31a).
9. Install the three remaining screws (31d). Torque to 7–9 in-lb (0.8–1.0 N•m).

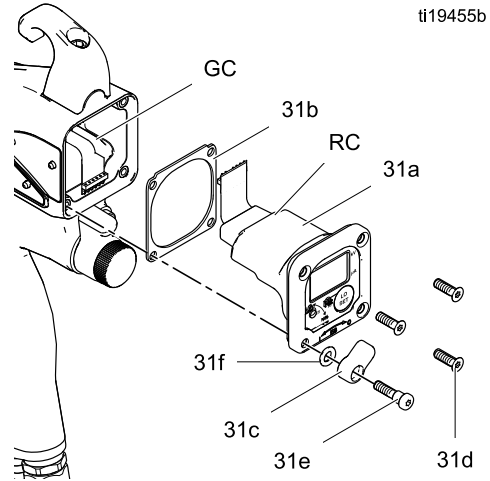

Figure 42 Smart Module

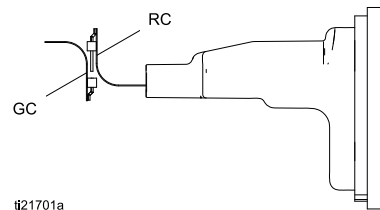

Figure 43 Align Ribbon Cables

Air Swivel and Exhaust Valve Replacement

1. See [Prepare the Gun for Service, page 39](#).
2. To replace the air exhaust valve:
 - a. Remove the clamp (36) and the exhaust tube (35).
 - b. Unscrew the swivel (21) from the gun handle (16). The swivel is a left-hand thread. Remove the bracket (7).
 - c. Pull the exhaust valve (8) from the handle (16). Inspect the o-ring (8a) and replace if necessary.
 - d. Install the o-ring (8a*) on the exhaust valve (8). Lubricate the o-ring with a light coating of non-silicone grease.
 - e. Install the exhaust valve (8) in the handle (16).
 - f. Apply thread sealant to the top threads of the swivel (21). Position the bracket (7) and screw the swivel into the gun handle (16). Torque to 75–85 in-lb (8.4–9.6 N•m).
 - g. Install the tube (35) and clamp (36).
3. To replace the air inlet swivel:
 - a. Unscrew the swivel (21) from the gun handle (16). The swivel is a left-hand thread.
 - b. Apply thread sealant to the top threads of the swivel. Screw the swivel into the gun handle. Torque to 75–85 in-lb (8.4–9.6 N•m).

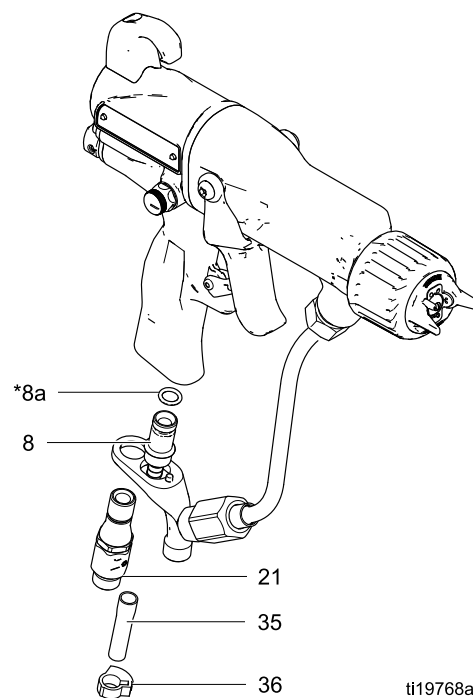

Figure 44 Air Inlet Fitting and Air Exhaust Valve

ti19768a

Parts

Standard Air-Assisted Spray Gun Assembly

Part No. H60T10 60 kV Electrostatic Air-Assisted Spray Gun, Series B
Part No. H85T10 85 kV Electrostatic Air-Assisted Spray Gun, Series B

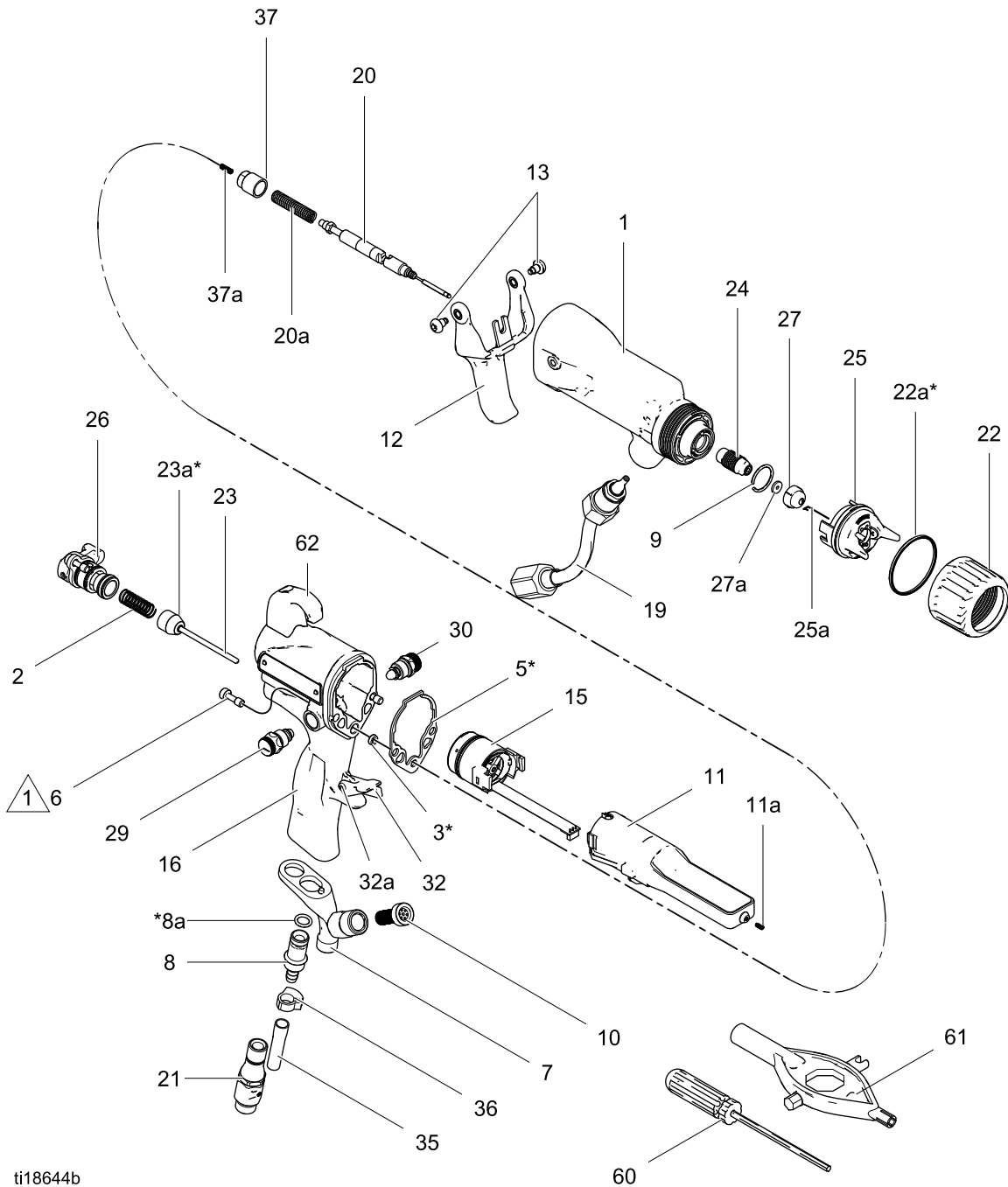

ti18644b

1 Torque to 20 in-lb (2 N•m).

Part No. H60T10 60 kV Electrostatic Air-Assisted Spray Gun, Series B
Part No. H85T10 85 kV Electrostatic Air-Assisted Spray Gun, Series B

Ref. No.	Part No.	Description	Qty
1	24N746	BODY, gun; 60 kV gun, includes gasket (5)	1
	24N745	BODY, gun; 85 kV gun, includes gasket (5)	1
2	185116	SPRING, compression	1
3*	188749	PACKING, u-cup	1
5*	24N699	GASKET, body	1
6	24N740	SCREW, hex socket; pack of 2	1
7	24N742	BRACKET	1
8	249323	VALVE, exhaust	1
8a*	112085	O-RING	1
9	24N747	RING, conductive	1
10	238562	FILTER, inline, 100 mesh; see note below	1
11	24N660	POWER SUPPLY, 60 kV gun	1
	24N661	POWER SUPPLY, 85 kV gun	1
12	24N663	TRIGGER; includes item 13	1
13	24A445	SCREW, trigger; package of 2	1
15	24N664	See Alternator Assembly, page 58	1
16	24N761	HANDLE; 60 kV AA gun	1
	24N762	HANDLE; 85 kV AA gun	1
19	24N744	TUBE, fluid; 60 kV gun	1
	24N743	TUBE, fluid; 85 kV gun	1
20	24N780	NEEDLE ASSEMBLY; 60 kV gun; includes item 20a	1
	24N781	NEEDLE ASSEMBLY; 85 kV gun; includes item 20a	1
20a	24N782	SPRING, fluid needle	1
21	24N626	SWIVEL, air inlet; M12 x 1/4 npsm(m); left-hand thread	1
22	24N793	RING, retainer; includes 22a	1
22a*	198307	PACKING, u-cup; UHMWPE; part of 22	1
23	24N633	VALVE, air	1
23a*	276733	SEAL	1

▲ Replacement Danger and Warning labels, tags, and cards are available at no cost.

* These parts are included in Air Seal Repair Kit 24N789 (purchase separately).

✱ EX On/Off Valve Restrictor Kit 26A294 is available for customers with high atomization air pressure applications. Use this accessory if the turbine light indicator is red and

Ref. No.	Part No.	Description	Qty
24	24N725	HOUSING, seat	1
25	24N727	See Air Cap Assembly, page 61	1
25a	24N643	ELECTRODE; package of 5	1
26✱	24N632	See ES On-Off Valve Assembly, page 59	1
27	AEMxxx AEFxxx	TIP ASSEMBLY; customer's choice; includes item 27a	1
27a	183459	GASKET, tip	1
29	24N792	ATOMIZING AIR ADJUSTMENT VALVE	1
30	24N634	See Fan Air Valve Assembly, page 60	1
32	24E404	STOP, trigger; includes item 32a	1
32a	— — —	PIN, dowel	1
35	185103	TUBE, exhaust; 1/4 in. (6 mm) ID (shipped loose)	1
36	110231	CLAMP	1
37	24N785	CAP, spring; includes item 37a	1
37a	197624	SPRING, compression	1
38	24N786	PLUG, fan control; option, shipped loose for use in place of item 29	1
51	112080	TOOL, needle (shipped loose)	1
54	24N603	COVER, gun, 60 kV guns; package of 10	1
	24N604	COVER, gun, 85 kV guns; package of 10	1
55▲	179791	TAG, warning (not shown)	1
56▲	16P802	SIGN, warning (not shown)	1
57	116553	GREASE, dielectric; 1 oz (30 ml) tube (not shown)	1
58	117824	GLOVE, conductive, medium; package of 12; also available in small (117823) and large (117825)	1
60	107460	TOOL, wrench, ball end (shipped loose)	1
61	276741	MULTI-TOOL (shipped loose)	1
62	24N783	HOOK; includes screw	1

you want to maintain a higher application air pressure. Install the kit, then adjust the pressure as needed to ensure operation in the green light.

NOTE: 100 mesh Filter Kits (10) are available. Order 238561 (qty 3) or 224453 (qty 5).

Parts labeled — — — are not available separately.

Smart Air-Assisted Spray Gun Assembly

Part No. H60M10 60 kV Electrostatic Air-Assisted Spray Gun, Series B

Part No. H85M10 85 kV Electrostatic Air-Assisted Spray Gun, Series B

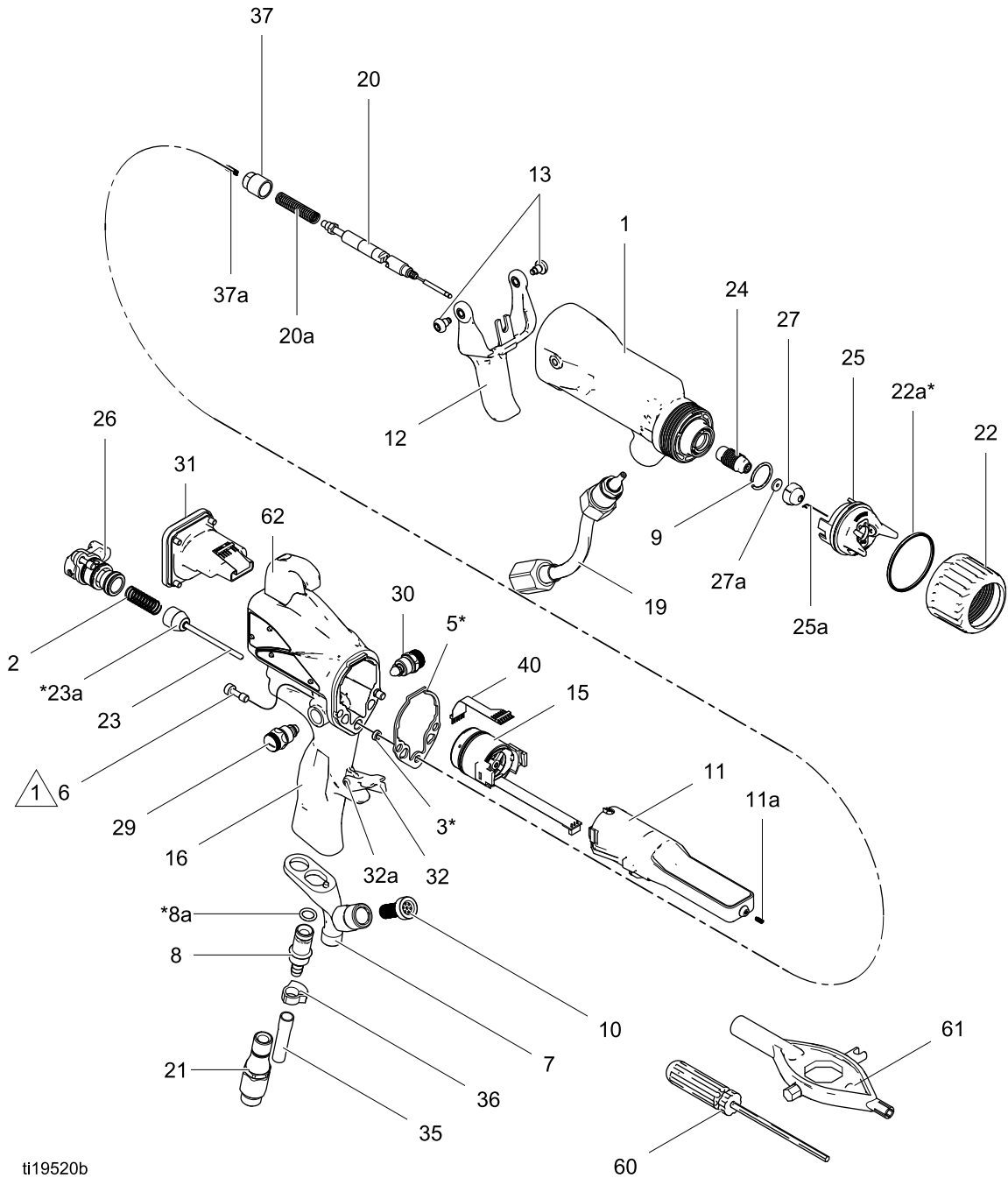

ti19520b

 Torque to 20 in-lb (2 N•m).

Part No. H60M10 60 kV Electrostatic Air-Assisted Spray Gun, Series B
Part No. H85M10 85 kV Electrostatic Air-Assisted Spray Gun, Series B

Ref. No.	Part No.	Description	Qty
1	24N746	BODY, gun; 60 kV gun, includes gasket (5)	1
	24N745	BODY, gun; 85 kV gun, includes gasket (5)	1
2	185116	SPRING, compression	1
3*	188749	PACKING, u-cup	1
5*	24N699	GASKET, body	1
6	24N740	SCREW, hex socket; sst; package of 2	1
7	24N742	BRACKET	1
8	249323	VALVE, exhaust	1
8a*	112085	O-RING	1
9	24N747	RING, conductive	1
10	238562	FILTER, inline, 100 mesh; see note below	1
11	24N660	POWER SUPPLY, 60 kV gun	1
	24N661	POWER SUPPLY, 85 kV gun	1
12	24N663	TRIGGER; includes item 13	1
13	24A445	SCREW, trigger; package of 2	1
15	24N664	See Alternator Assembly, page 58	1
16	24N763	HANDLE, smart; 60 kV AA gun	1
	24N764	HANDLE, smart; 85 kV AA gun	1
19	24N744	TUBE, fluid; 60 kV gun	1
	24N743	TUBE, fluid; 85 kV gun	1
20	24N780	NEEDLE ASSEMBLY; 60 kV gun; includes item 20a	1
	24N781	NEEDLE ASSEMBLY; 85 kV gun; includes item 20a	1
20a	24N782	SPRING, fluid needle	1
21	24N626	SWIVEL, air inlet; M12 x 1/4 npsm(m); left-hand thread	1
22	24N793	RING, retainer; includes 22a	1
22a*	198307	PACKING, u-cup; UHMWPE; part of 22	1
23	24N633	VALVE, air	1
23a*	276733	SEAL	1
24	24N725	HOUSING, seat	1
25	24N727	See Air Cap Assembly, page 61	1

▲ Replacement Danger and Warning labels, tags, and cards are available at no cost.

* These parts are included in Air Seal Repair Kit 24N789 (purchase separately).

Ref. No.	Part No.	Description	Qty
25a	24N643	ELECTRODE; package of 5	1
26	24N632	See ES On-Off Valve Assembly, page 59	1
27	AEMxxx AEFxxx	TIP ASSEMBLY; customer's choice; includes item 27a	1
27a	183459	GASKET, tip	1
29	24N792	ATOMIZING AIR ADJUSTMENT VALVE	1
30	24N634	See Fan Air Valve Assembly, page 60	1
31	24N756	See Smart Module Assembly, page 61	1
32	24E404	STOP, trigger; includes item 32a	1
32a	— — —	PIN, dowel	1
35	185103	TUBE, exhaust; 1/4 in. (6 mm) ID (shipped loose)	1
36	110231	CLAMP	1
37	24N785	CAP, spring; includes item 37a	1
37a	197624	SPRING, compression	1
38	24N786	PLUG, fan control; option, shipped loose for use in place of item 29	1
40	245265	CIRCUIT, flexible	1
51	112080	TOOL, needle (shipped loose)	1
54	24N603	COVER, gun, 60 kV guns; package of 10	1
	24N604	COVER, gun, 85 kV guns; package of 10	1
55▲	179791	TAG, warning (not shown)	1
56▲	16P802	SIGN, warning (not shown)	1
57	116553	GREASE, dielectric; 1 oz (30 ml) tube (not shown)	1
58	117824	GLOVE, conductive, medium; package of 12; also available in small (117823) and large (117825)	1
60	107460	TOOL, wrench, ball end (shipped loose)	1
61	276741	MULTI-TOOL (shipped loose)	1
62	24N783	HOOK; includes screw	1

NOTE: 100 mesh Filter Kits (10) are available. Order 238561 (qty 3) or 224453 (qty 5).

Parts labeled — — — are not available separately.

Alternator Assembly

Part No. 24N664 Alternator Assembly

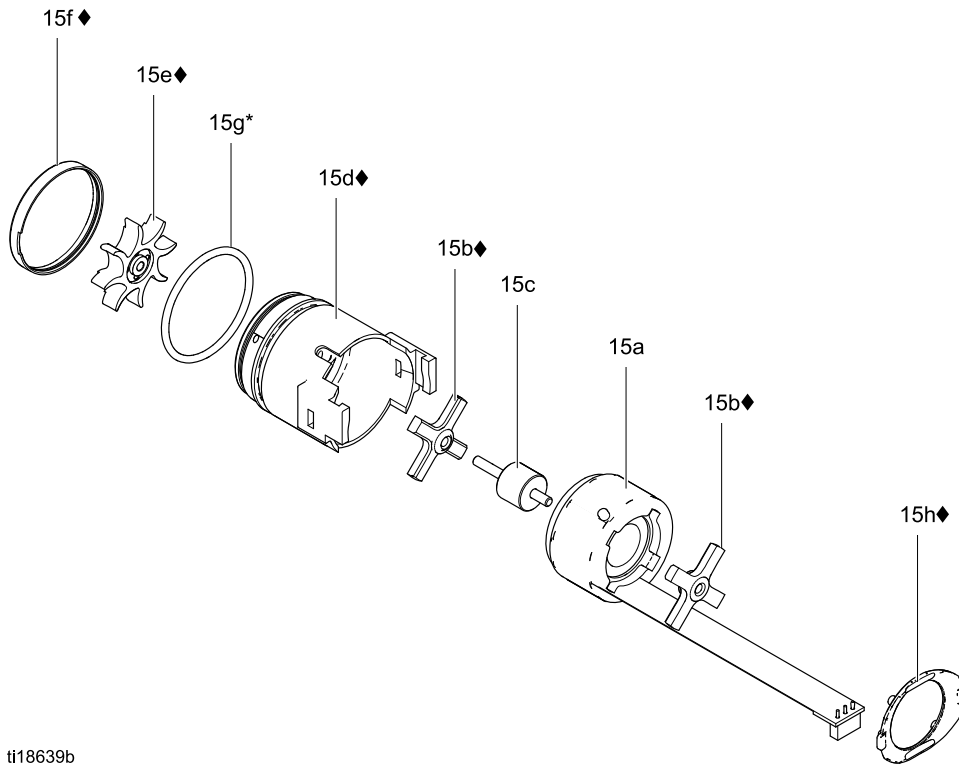

tf18639b

Ref. No.	Part No.	Description	Qty
15a	24N705	COIL, alternator	1
15b◆	24N706	BEARING KIT (includes two bearings, item 15d housing, item 15e fan, item 15f cap, and one item 15h clip)	1
15c	24Y264	SHAFT KIT (includes shaft and magnet)	1
15d◆	24N707	HOUSING; includes item 15f	1
15e◆	— — —	FAN; part of item 15b	1

Ref. No.	Part No.	Description	Qty
15f◆	— — —	CAP, housing; part of item 15d	1
15g*	110073	O-RING	1
15h◆	24N709	CLIP; package of 5 (one clip included with item 15b)	1
5◆*	24N699	GASKET, barrel (not shown in drawing)	1

* These parts are included in Air Seal Repair Kit 24N789 (purchase separately).

◆ These parts are included in Bearing Kit 24N706 (purchase separately).

Parts labeled — — — are not available separately.

ES On-Off Valve Assembly

Part No. 24N632 ES On-Off Valve Assembly

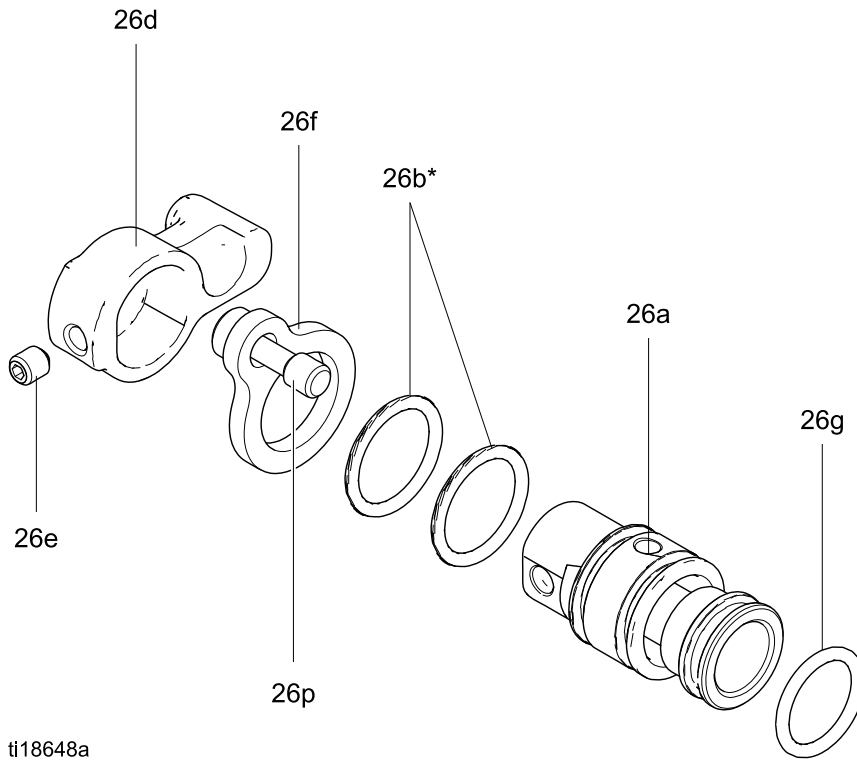

ti18648a

Ref. No.	Part No.	Description	Qty
26a	— — —	HOUSING, valve	1
26b*	15D371	O-RING	2
26c	— — —	PISTON, valve	1
26d	24N650	LEVER, ES on-off; includes item 26e	1

Ref. No.	Part No.	Description	Qty
26e	— — —	SCREW, set, socket head	2
26f	24N631	PLATE, retaining	1
26g*	113746	O-RING	1
26p	— — —	SCREW, captive	1

* These parts are included in Air Seal Repair Kit 24N789 (purchase separately).

Parts labeled — — — are not available separately.

Fan Air Valve Assembly

Part No. 24N634 Fan Air Valve Assembly

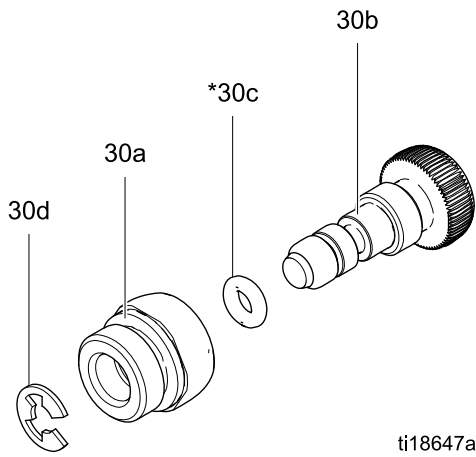

Ref. No.	Part No.	Description	Qty
30a	— — —	NUT, valve	1
30b	— — —	STEM, valve	1
30c*	111504	O-RING	1
30d	24N646	RING, retaining; package of 6	1

* These parts are included in Air Seal Repair Kit 24N789 (purchase separately).

Parts labeled — — — are not available separately.

Air Cap Assembly

Part No. 24N727 Air Cap Assembly

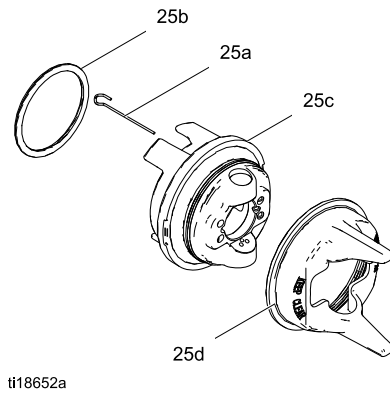

Ref. No.	Part No.	Description	Qty
25a	24N643	ELECTRODE; package of 5	1
25b	24N734	O-RING; ptfе; package of 5 (also available in package of 10; order 24E459)	1
25c	— — —	AIR CAP	1
25d	24N726	GUARD, tip, orange	1
27a	183459	GASKET, tip (not shown)	5

Parts labeled — — — are not available separately.

Smart Module Assembly

Part No. 24N756 Smart Module Assembly

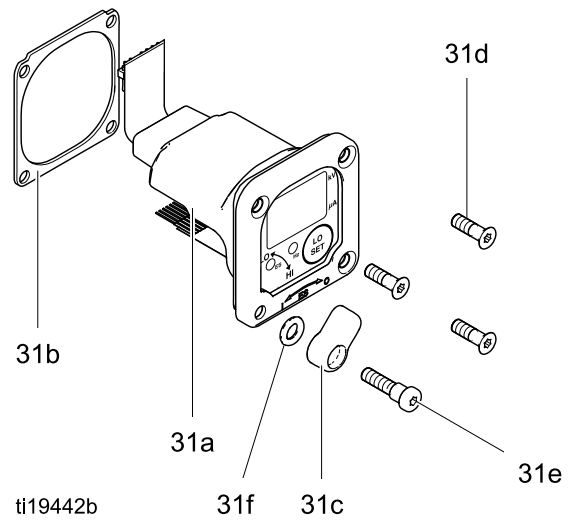

Ref. No.	Part No.	Description	Qty
31a	— — —	CARTRIDGE	1
31b	24P433	GASKET	1
31c	24N787	SWITCH, ES HI/LO	1
31d♦	— — —	SCREW	3
31e♦	— — —	SCREW, pivot	1
31f	112319	O-RING	1

Parts labeled — — — are not available separately.

♦ These parts are included in Smart Module Screw Kit 24N757 (purchase separately).

Spray Tip Selection Chart

AEM Fine Finish Spray Tips

Recommended for high finish quality applications at low and medium pressures. Order desired tip, **Part No. AEMxxx**, where xxx = 3-digit number from the matrix below.

Orifice Size in. (mm)	Fluid Output fl oz/min (l/min)		Maximum Pattern Width at 12 in. (305 mm) in. (mm)							
	at 600 psi (4.1 MPa, 41 bar)	at 1000 psi (7.0 MPa, 70 bar)	2-4 (50- 100)	4-6 (100- 150)	6-8 (150- 200)	8-10 (200- 250)	10-12 (250- 300)	12-14 (300- 350)	14-16 (350- 400)	16-18 (400- 450)
			Spray Tip							
0.007 (0.178)	4.0 (0.1)	5.2 (0.15)	107	207	307					
0.009 (0.229)	7.0 (0.2)	9.1 (0.27)		209	309	409	509	609		
0.011 (0.279)	10.0 (0.3)	13.0 (0.4)		211	311	411	511	611	711	
0.013 (0.330)	13.0 (0.4)	16.9 (0.5)		213	313	413	513	613	713	813
0.015 (0.381)	17.0 (0.5)	22.0 (0.7)		215	315	415	515	615	715	815
0.017 (0.432)	22.0 (0.7)	28.5 (0.85)		217	317	417	517	617	717	
0.019 (0.483)	28.0 (0.8)	36.3 (1.09)			319	419	519	619	719	
0.021 (0.533)	35.0 (1.0)	45.4 (1.36)				421	521	621	721	821
0.023 (0.584)	40.0 (1.2)	51.9 (1.56)				423	523	623	723	823
0.025 (0.635)	50.0 (1.5)	64.8 (1.94)				425	525	625	725	825
0.029 (0.736)	68.0 (1.9)	88.2 (2.65)								829
0.031 (0.787)	78.0 (2.2)	101.1 (3.03)				431		631		831
0.033 (0.838)	88.0 (2.5)	114.1 (3.42)								833
0.037 (0.939)	108.0 (3.1)	140.0 (4.20)							737	
0.039 (0.990)	118.0 (3.4)	153.0 (4.59)					539			
* Tips are tested in water.										
Fluid output (Q) at other pressures (P) can be calculated by this formula: $Q = (0.041) (QT) \sqrt{P}$ where QT = fluid output (fl oz/min) at 600 psi from the above table for the selected orifice size.										

AEF Fine Finish Pre-Orifice Spray Tips

Recommended for high finish quality applications at low and medium pressures. AEF tips have a pre-orifice that assists in atomizing sheer thinning materials, including lacquers.

Order desired tip, **Part No. AEFxxx**, where xxx = 3-digit number from the matrix below.

Orifice Size in. (mm)	Fluid Output fl oz/min (l/min)		Maximum Pattern Width at 12 in. (305 mm) in. (mm)					
	at 600 psi (4.1 MPa, 41 bar)	at 1000 psi (7.0 MPa, 70 bar)	6-8 (150- 200)	8-10 (200-250)	10-12 (250-300)	12-14 (300-350)	14-16 (350-400)	16-18 (400-450)
			Spray Tip					
† 0.010 (0.254)	9.5 (0.28)	12.5 (0.37)	310	410	510	610	710	
0.012 (0.305)	12.0 (0.35)	16.0 (0.47)	312	412	512	612	712	812
0.014 (0.356)	16.0 (0.47)	21.0 (0.62)	314	414	514	614	714	814
0.016 (0.406)	20.0 (0.59)	26.5 (0.78)		416	516	616	716	
* Tips are tested in water.								
Fluid output (Q) at other pressures (P) can be calculated by this formula: $Q = (0.041) (QT) \sqrt{P}$ where QT = fluid output (fl oz/min) at 600 psi from the above table for the selected orifice size.								
† These tip sizes include a 150 mesh filter.								

Repair Kits, Related Manuals, and Accessories

Gun Part No.	Description	Manual Description	Repair Kits	Repair Kit Description
All guns in this manual.	60 kV and 85 kV Air-Assisted Spray Guns	Electrostatic Air-Assisted Spray Guns, Instructions-Parts	24N789	Air Seal Repair Kit
			24N706	Alternator Bearing Repair Kit

System Accessories

Gun Accessories

Part No.	Description
105749	Cleaning Brush.
111265	Non-silicone Lubricant, 4 oz (113 g).
116553	Dielectric Grease. 1 oz (30 ml)
24N319	Round Spray Kit. To convert a standard air—assisted spray gun to a round spray air cap. See manual 3A2499.
24N603	Gun Covers. For 40 kV and 60 kV guns. Box of 10.
24N604	Gun Covers. For 85 kV guns. Box of 10.
24N642	Ball Swivel, for gun air inlet. 1/4 npsm (left-hand thread)
24N758	Display Covers. Keeps Smart display clean. Package of 5.
24P170	Metal Trigger Kit.
24P172	Quick Adjust Valve. For quick change of fan size.
185105	Non-swivel Air Inlet; 1/4–18 npsm(m) (left-hand thread)
185493	Air Hose Adapter; 1/4 npt(m) x 1/4–18 npsm(m) (left-hand thread)
112534	Air Line Quick Disconnect Fitting.
26A294	ES On/Off Valve Restrictor for high atomization air applications. Use this accessory if the turbine light indicator is red and you want to maintain a higher application air pressure. Install the kit, then adjust the pressure as needed to ensure operation in the green light.

Part No.	Description
222011	Ground Wire and Clamp.
16P802	English Warning Sign. Available at no charge from Graco.
16P798	English Daily Care Sign.
16P799	English Setup Sign
24N528	Gun Flush Box Adapter. To convert existing gun flush boxes to hold Pro Xp guns.
24P312	Gun Washer Kit. To convert existing gun washers to clean Pro Xp guns.

Test Equipment

Part No.	Description
241079	Megohmmeter. 500 V output, 0.01–2000 megohms. Use for ground continuity and gun resistance tests. Not for use in hazardous areas.
722886	Paint Resistance Meter. Use for fluid resistivity test. See manual 307263. Not for use in hazardous areas.
722860	Paint Probe. Use for fluid resistivity test. See manual 307263. Not for use in hazardous areas.
245277	Test Fixture, High Voltage Probe, and kV Meter. Use to test the electrostatic voltage of the gun, and the condition of the alternator and power supply when being serviced. See manual 309455.

Hoses

Grounded Air Hoses

100 psi (0.7 MPa, 7 bar) Maximum Working Pressure

0.315 in. (8 mm) ID; 1/4 npsm(f) x 1/4 npsm(f)
left-hand thread

Part No.	Description
AirFlex Flexible Grounded Air Hose (Gray)	
244963	6 ft (1.8 m)
244964	15 ft (4.6 m)
244965	25 ft (7.6 m)
244966	36 ft (11 m)
244967	50 ft (15 m)
244968	75 ft (23 m)
244969	100 ft (30.5 m)

Part No.	Description
Standard Grounded Air Hose (Gray)	
223068	6 ft (1.8 m)
223069	15 ft (4.6 m)
223070	25 ft (7.6 m)
223071	36 ft (11 m)
223072	50 ft (15 m)
223073	75 ft (23 m)
223074	100 ft (30.5 m)
0.375 in. (10 mm) ID; 3/8 npsm(f) x 1/4 npsm(f) left-hand thread	
24A225	50 ft (15 m)
24A226	75 ft (23 m)

Part No.	Description
Grounded Air Hose with stainless steel braid ground path (Red)	
235068	6 ft (1.8 m)
235069	15 ft (4.6 m)
235070	25 ft (7.6 m)
235071	36 ft (11 m)
235072	50 ft (15 m)
235073	75 ft (23 m)
235074	100 ft (30.5 m)

Air Whip Hoses

100 psi (0.7 MPa, 7 bar) Maximum Working Pressure

0.188 in. (5 mm) ID; 1/4 npsm(m) x 1/4 npsm(f)
left-hand thread

Part No.	Description
Air Whip Hose with stainless steel braid ground path (Red)	
236130	3 ft (0.9 m)
236131	6 ft (1.8 m)

Fluid Hoses

3300 psi (22.7 MPa, 227 bar) Maximum Working
Pressure

1/4 in. (6 mm) ID; 1/4 npsm(fbe); nylon.

Part No.	Description
240793	25 ft (7.6 m)
240794	50 ft (15 m)

Fluid Whip Hoses

3200 psi (22 MPa, 220 bar) Maximum Working
Pressure

1/8 in. (3 mm) ID; 1/4 npsm(f) x 1/4 npt(m); nylon.

Part No.	Description
236134	3 ft (0.9 m)
236135	6 ft (1.8 m)

Operator Accessories

Part No.	Description
117823	Conductive Gloves, box of 12 (small)
117824	Conductive Gloves, box of 12 (medium)
117825	Conductive Gloves, box of 12 (large)
24N520	Comfort Grip. Snap-on grip increases handle size to reduce operator fatigue. Medium size.
24N521	Comfort Grip. Snap-on grip increases handle size to reduce operator fatigue. Large size.

Dimensions

ti19533a

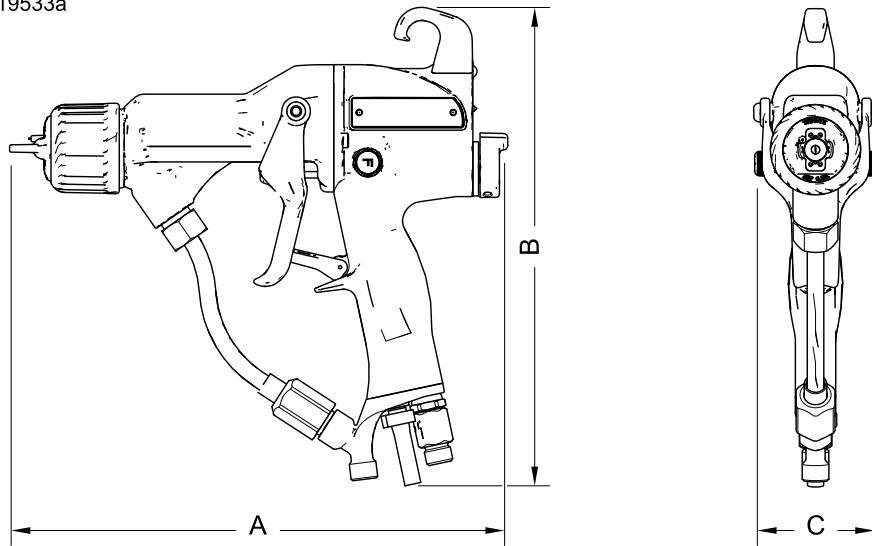

Figure 45

Gun Model	A, in. (mm)	B, in. (mm)	C, in. (mm)	Weight, oz (g)
H60T10	9.7 (246)	9.1 (231)	2.4 (61)	23.2 (659)
H85T10	10.7 (272)	9.2 (234)	2.4 (61)	25.8 (732)
H60M10	9.8 (249)	9.9 (251)	2.4 (61)	25.7 (728)
H85M10	10.8 (274)	9.9 (251)	2.4 (61)	28.3 (801)

Technical Data

Electrostatic Air-Assisted Spray Guns		
	U.S.	Metric
Maximum Working Fluid Pressure	3000 psi	21 MPa, 210 bar
Maximum Working Air Pressure	100 psi	0.7 MPa, 7.0 bar
Minimum Air Pressure at Gun Inlet	45 psi	0.32 MPa, 3.2 bar
Maximum Fluid Operating Temperature	120°F	48°C
Ambient Temperature	41°–122°F	5°–50°C
Paint Resistivity Range	3 megohm/cm to infinity	
Air Inlet Fitting	1/4 npsm(m) left-hand thread	
Fluid Inlet Fitting	1/4–18 npsm(m)	
Output Voltage	Pro Xp60 Models: 60 kV Pro Xp85 Models: 85 kV	
Maximum Current Draw	125 microamperes	
Sound Power (measured per ISO Standard 9216)	at 40 psi: 88.9 dB(A) at 100 psi: 99.7 dB(A)	at 0.28 MPa, 2.8 bar: 88.9 dB(A) at 0.7 MPa, 7.0 bar: 99.7 dB(A)
Sound Pressure (measured 1 m from gun)	at 40 psi: 86.0 dB(A) at 100 psi: 95.0 dB(A)	at 0.28 MPa, 2.8 bar: 86.0 dB(A) at 0.7 MPa, 7.0 bar: 95.0 dB(A)
Wetted Parts	PEEK, UHMWPE, FEP, PTFE, acetal, nylon, polyethylene	

Graco Pro Xp Warranty

Graco warrants all equipment referenced in this document which is manufactured by Graco and bearing its name to be free from defects in material and workmanship on the date of sale to the original purchaser for use. With the exception of any special, extended, or limited warranty published by Graco, Graco will, for a period of twelve months from the date of sale, repair or replace any part of the equipment determined by Graco to be defective. However, any deficiency in the barrel, handle, trigger, hook, internal power supply, and alternator (excluding turbine bearings) will be repaired or replaced for thirty-six months from the date of sale. This warranty applies only when the equipment is installed, operated and maintained in accordance with Graco's written recommendations.

This warranty does not cover, and Graco shall not be liable for general wear and tear, or any malfunction, damage or wear caused by faulty installation, misapplication, abrasion, corrosion, inadequate or improper maintenance, negligence, accident, tampering, or substitution of non-Graco component parts. Nor shall Graco be liable for malfunction, damage or wear caused by the incompatibility of Graco equipment with structures, accessories, equipment or materials not supplied by Graco, or the improper design, manufacture, installation, operation or maintenance of structures, accessories, equipment or materials not supplied by Graco.

This warranty is conditioned upon the prepaid return of the equipment claimed to be defective to an authorized Graco distributor for verification of the claimed defect. If the claimed defect is verified, Graco will repair or replace free of charge any defective parts. The equipment will be returned to the original purchaser transportation prepaid. If inspection of the equipment does not disclose any defect in material or workmanship, repairs will be made at a reasonable charge, which charges may include the costs of parts, labor, and transportation.

THIS WARRANTY IS EXCLUSIVE, AND IS IN LIEU OF ANY OTHER WARRANTIES, EXPRESS OR IMPLIED, INCLUDING BUT NOT LIMITED TO WARRANTY OF MERCHANTABILITY OR WARRANTY OF FITNESS FOR A PARTICULAR PURPOSE.

Graco's sole obligation and buyer's sole remedy for any breach of warranty shall be as set forth above. The buyer agrees that no other remedy (including, but not limited to, incidental or consequential damages for lost profits, lost sales, injury to person or property, or any other incidental or consequential loss) shall be available. Any action for breach of warranty must be brought within two (2) years of the date of sale.

GRACO MAKES NO WARRANTY, AND DISCLAIMS ALL IMPLIED WARRANTIES OF MERCHANTABILITY AND FITNESS FOR A PARTICULAR PURPOSE, IN CONNECTION WITH ACCESSORIES, EQUIPMENT, MATERIALS OR COMPONENTS SOLD BUT NOT MANUFACTURED BY GRACO. These items sold, but not manufactured by Graco (such as electric motors, switches, hose, etc.), are subject to the warranty, if any, of their manufacturer. Graco will provide purchaser with reasonable assistance in making any claim for breach of these warranties.

In no event will Graco be liable for indirect, incidental, special or consequential damages resulting from Graco supplying equipment hereunder, or the furnishing, performance, or use of any products or other goods sold hereto, whether due to a breach of contract, breach of warranty, the negligence of Graco, or otherwise.

FOR GRACO CANADA CUSTOMERS

The Parties acknowledge that they have required that the present document, as well as all documents, notices and legal proceedings entered into, given or instituted pursuant hereto or relating directly or indirectly hereto, be drawn up in English. Les parties reconnaissent avoir convenu que la rédaction du présente document sera en Anglais, ainsi que tous documents, avis et procédures judiciaires exécutés, donnés ou intentés, à la suite de ou en rapport, directement ou indirectement, avec les procédures concernées.

Graco Information

For the latest information about Graco products, visit www.graco.com.

To place an order, contact your Graco Distributor or call to identify the nearest distributor.

Phone: 612-623-6921 **or Toll Free:** 1-800-328-0211 **Fax:** 612-378-3505

All written and visual data contained in this document reflects the latest product information available at the time of publication.

Graco reserves the right to make changes at any time without notice.

For patent information, see www.graco.com/patents.

Original Instructions. This manual contains English, MM 3A2495

Graco Headquarters: Minneapolis

International Offices: Belgium, China, Japan, Korea

GRACO INC. AND SUBSIDIARIES • P.O. BOX 1441 • MINNEAPOLIS, MN 55440-1441 • USA

Copyright 2012, Graco Inc. All Graco manufacturing locations are registered to ISO 9001.

www.graco.com

Revision F, December 2016