

REACTOR[®] A-25/A-XP1

PLURAL COMPONENT PROPORTIONER

3A1570R

EN

Air operated, electrically heated, plural component proportioner

A-25: For spraying or dispensing 1:1 ratio polyurethane foam formulations and other 1:1 fast setting materials.

A-XP1: For spraying or dispensing 1:1 ratio polyurea formulations and other 1:1 fast setting materials.

Not for use in explosive atmosphere or hazardous locations.

This model is field-configurable to the following supply voltages:

200-240 VAC, 1 Phase

200-240 VAC, 3 Phase

350-415 VAC, 3 Phase

A-25:

2000 psi (14 MPa, 138 bar) Maximum Fluid Working Pressure

80 psi (550 kPa, 5.5 bar) Maximum Air Working Pressure

A-XP1:

3500 psi (24 MPa, 241 bar) Maximum Fluid Working Pressure

100psi (689 kPa, 6.9 bar) Maximum Air Working Pressure



Important Safety Instructions

Read all warnings and instructions in this manual. Save these instructions.

See page 3 for model information, including maximum working pressure and approvals.

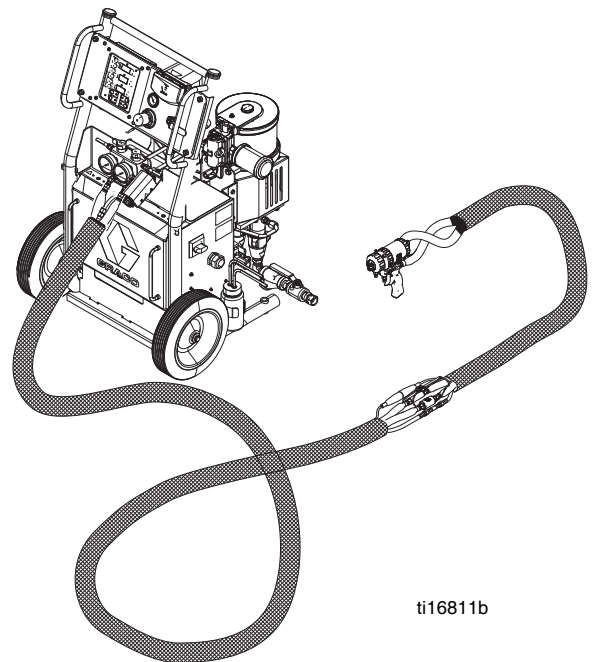

ti16811b

Contents

| | | | |
|---|-----------|--|-----------|
| Proportioner Models | 3 | Parts | 41 |
| Systems | 3 | Control Panel, A-25: 262575, A-XP1: 24Y176 | 45 |
| Related Manuals | 4 | Temperature Control | 46 |
| Warnings | 5 | Wheel Kit, 262695 | 46 |
| Important Isocyanate (ISO) Information | 8 | Fluid Manifold | 47 |
| Isocyanate Conditions | 8 | Fluid Inlet Kit, 234366 | 47 |
| Material Self-ignition | 9 | A-XP1: 10 kw Dual Zone Heater, 24Y163 | |
| Keep Components A and B Separate | 9 | A-25: 6 kw Dual Zone Heater, 24J788 | 48 |
| Moisture Sensitivity of Isocyanates | 9 | A-25 Air Motor Pump Assembly, 262573 | |
| Foam Resins with 245 fa Blowing Agents | 9 | A-XP1 Air Motor Pump Assembly, 24Y086 | 49 |
| Changing Materials | 9 | Air Tubing Connections | 50 |
| E02: High zone current | 12 | A-25 Breaker Module, 262576 | |
| E03: No zone current | 12 | A-XP1 Breaker Module, 24Y166 | 51 |
| E04: Fluid Temperature Sensor (FTS) or thermocouple disconnected | 12 | Reactor A-25/A-XP1 Wiring Schematic | 52 |
| E05: Control board over temperature | 13 | A-25 | 53 |
| E06: Communication cable unplugged | 13 | A-XP1 | 54 |
| E30: Momentary loss of communication | 13 | A-25 | 55 |
| E99: Loss of communication | 13 | A-XP1 | 56 |
| Before Beginning Repair | 14 | A-25 | 57 |
| Pressure Relief Procedure | 14 | A-XP1 | 58 |
| Shutdown | 14 | Technical Data | 59 |
| Park | 15 | Graco Standard Warranty | 60 |
| Flushing | 15 | Graco Information | 60 |
| Troubleshooting | 16 | | |
| Repair | 23 | | |
| Disconnect Pump | 23 | | |
| Connect Pump | 24 | | |
| Remove Air Motor | 25 | | |
| Install Air Motor | 25 | | |
| Recirculation / Over Pressure Relief Block | 26 | | |
| Air Inlet Filter / Water Separator (Auto Drain) | 26 | | |
| Temperature Control Module | 27 | | |
| Primary Heater | 29 | | |
| Heated Hose | 32 | | |
| Fluid Temperature Sensor (FTS) | 33 | | |
| Pump Lubrication System | 36 | | |
| Fluid Inlet Strainer Screen | 37 | | |
| Temperature Display | 37 | | |
| Accessories | 40 | | |
| Recommended Spare Parts | 40 | | |

Proportioner Models

All proportioners can be configured to operate on 350-415V (4 wire), 200-240V (3 wire), or 200-240V 1Ø.

| Part | Maximum Fluid Working Pressure psi (MPa, bar) | Maximum Air Working Set Pressure psi (kPa, bar) | Includes: | | Approvals |
|--------|--|--|--------------------------------|--------|--|
| | | | DataTrak (cycle count only) | Wheels | |
| 262572 | 2000 (14, 138) | 80 (550, 5.5) | --- | --- |  Intertek 3172585 <small>Conforms to ANSI/UL Std. 499 Certified to CAN/CSA Std. C22.2 No. 88</small> |
| 262614 | 2000 (14, 138) | 80 (550, 5.5) | 24A592 | ✓ | |
| 24Y164 | 3500 (24, 241) | 100 (689, 6.9) | --- | --- | |
| 24Y165 | 3500 (24, 241) | 100 (689, 6.9) | 24A592 | ✓ | |

Systems

All systems include a proportioner, spray gun, and 60 ft (18.3 m) of heated hose.

| Part | Maximum Working Pressure psi (MPa, bar) | Proportioner | Heated Hose | | Gun | |
|--------|--|--------------|--------------|-------------|------------|--------|
| | | | 50 ft (15 m) | 10 ft (3 m) | Model | Part |
| P22614 | 2000 (14, 138) | 262614 | 246678 | 246050 | Probler P2 | GCP2R1 |
| AP2614 | 2000 (14, 138) | 262614 | 246678 | 246050 | Fusion™ AP | 246101 |
| CS2614 | 2000 (14, 138) | 262614 | 246678 | 246050 | Fusion™ CS | CS01RD |
| P22572 | 2000 (14, 138) | 262572 | 246678 | 246050 | Probler P2 | GCP2R1 |
| AP2572 | 2000 (14, 138) | 262572 | 246678 | 246050 | Fusion™ AP | 246101 |
| CS2572 | 2000 (14, 138) | 262572 | 246678 | 246050 | Fusion™ CS | CS01RD |
| P2Y165 | 3500 (24, 241) | 24Y165 | 246679 | 246055 | Probler P2 | GCP2R1 |
| APY165 | 3500 (24, 241) | 24Y165 | 246679 | 246055 | Fusion™ AP | 246101 |
| P2Y164 | 3500 (24, 241) | 24Y164 | 246679 | 246055 | Probler P2 | GCP2R1 |
| APY164 | 3500 (24, 241) | 24Y164 | 246679 | 246055 | Fusion™ AP | 246101 |

Related Manuals





Manuals are available at www.graco.com.

Component manuals in English:

| Manual | Description |
|---------------|---|
| 3A1569 | Reactor A-25 Proportioner, Operation |
| 309577 | Proportioning Pump, Repair-Parts |
| 309815 | Feed Pump Kit, Instructions-Parts |
| 309827 | Feed Pump Air Supply Kit, Instructions-Parts |
| 309852 | Circulation and Return Tube Kit, Instructions-Parts |
| 309572 | Heated Hose, Instructions-Parts |
| 309550 | Fusion™ AP Spray Gun, Instructions-Parts |
| 312666 | Fusion™ CS Spray Gun, Instructions-Parts |
| 313213 | Probler P2 Spray Gun, Instructions-Parts |
| 313541 | DataTrak Kits, Installation-Parts |
| 312796 | NXT® Air Motor, Instructions-Parts |

Warnings

The following warnings are for the setup, use, grounding, maintenance, and repair of this equipment. The exclamation point symbol alerts you to a general warning and the hazard symbols refer to procedure-specific risks. When these symbols appear in the body of this manual, refer back to these Warnings. Product-specific hazard symbols and warnings not covered in this section may appear throughout the body of this manual where applicable.

|  <h2 style="margin: 0;">WARNING</h2> | |
|---|---|
|  | <p>ELECTRIC SHOCK HAZARD</p> <p>This equipment must be grounded. Improper grounding, setup, or usage of the system can cause electric shock.</p> <ul style="list-style-type: none"> • Turn off and disconnect power at main switch before disconnecting any cables and before servicing or installing equipment. • Connect only to grounded power source. • All electrical wiring must be done by a qualified electrician and comply with all local codes and regulations. |
|  | <p>TOXIC FLUID OR FUMES HAZARD</p> <p>Toxic fluids or fumes can cause serious injury or death if splashed in the eyes or on skin, inhaled or swallowed.</p> <ul style="list-style-type: none"> • Read Safety Data Sheet (SDS) for handling instructions and to know the specific hazards of the fluids you are using, including the effects of long-term exposure. • When spraying, servicing equipment, or when in the work area, always keep work area well ventilated and always wear appropriate personal protective equipment. See Personal Protective Equipment warnings in this manual. • Store hazardous fluid in approved containers, and dispose of it according to applicable guidelines. |
|  | <p>PERSONAL PROTECTIVE EQUIPMENT</p> <p>Always wear appropriate personal protective equipment and cover all skin when spraying, servicing equipment, or when in the work area. Protective equipment helps prevent serious injury, including long-term exposure; inhalation of toxic fumes, mists or vapors; allergic reaction; burns; eye injury and hearing loss. This protective equipment includes but is not limited to:</p> <ul style="list-style-type: none"> • A properly fitting respirator, which may include a supplied-air respirator, chemically impermeable gloves, protective clothing and foot coverings as recommended by the fluid manufacturer and local regulatory authority. • Protective eye wear and hearing protection. |
|  | <p>BURN HAZARD</p> <p>Equipment surfaces and fluid that's heated can become very hot during operation. To avoid severe burns:</p> <ul style="list-style-type: none"> • Do not touch hot fluid or equipment. |



WARNING



FIRE AND EXPLOSION HAZARD

Flammable fumes, such as solvent and paint fumes, in **work area** can ignite or explode. To help prevent fire and explosion:

- Use equipment only in well ventilated area.
- Eliminate all ignition sources; such as pilot lights, cigarettes, portable electric lamps, and plastic drop cloths (potential static arc).
- Keep work area free of debris, including solvent, rags and gasoline.
- Do not plug or unplug power cords, or turn power or light switches on or off when flammable fumes are present.
- Ground all equipment in the work area. See **Grounding** instructions.
- Use only grounded hoses.
- Hold gun firmly to side of grounded pail when triggering into pail.
- If there is static sparking or you feel a shock, **stop operation immediately**. Do not use equipment until you identify and correct the problem.
- Keep a working fire extinguisher in the work area.



SKIN INJECTION HAZARD









High-pressure fluid from gun, hose leaks, or ruptured components will pierce skin. This may look like just a cut, but it is a serious injury that can result in amputation. **Get immediate surgical treatment.**

- Engage trigger lock when not spraying.
- Do not point gun at anyone or at any part of the body.
- Do not put your hand over the fluid outlet.
- Do not stop or deflect leaks with your hand, body, glove, or rag.
- Follow the **Pressure Relief Procedure** when you stop spraying and before cleaning, checking, or servicing equipment.
- Tighten all fluid connections before operating the equipment.
- Check hoses and couplings daily. Replace worn or damaged parts immediately.





WARNING

| | |
|---|--|
|   | <p>EQUIPMENT MISUSE HAZARD</p> <p>Misuse can cause death or serious injury.</p> <ul style="list-style-type: none"> • Do not operate the unit when fatigued or under the influence of drugs or alcohol. • Do not exceed the maximum working pressure or temperature rating of the lowest rated system component. See Technical Data in all equipment manuals. • Use fluids and solvents that are compatible with equipment wetted parts. See Technical Data in all equipment manuals. Read fluid and solvent manufacturer's warnings. For complete information about your material, request MSDS from distributor or retailer. • Do not leave the work area while equipment is energized or under pressure. Turn off all equipment and follow the Pressure Relief Procedure when equipment is not in use. • Check equipment daily. Repair or replace worn or damaged parts immediately with genuine manufacturer's replacement parts only. • Do not alter or modify equipment. • Use equipment only for its intended purpose. Call your distributor for information. • Route hoses and cables away from traffic areas, sharp edges, moving parts, and hot surfaces. • Do not kink or over bend hoses or use hoses to pull equipment. • Keep children and animals away from work area. • Comply with all applicable safety regulations. |
|  | <p>PRESSURIZED ALUMINUM PARTS HAZARD</p> <p>Use of fluids that are incompatible with aluminum in pressurized equipment can cause serious chemical reaction and equipment rupture. Failure to follow this warning can result in death, serious injury, or property damage.</p> <ul style="list-style-type: none"> • Do not use 1,1,1-trichloroethylene, methylene chloride, other halogenated hydrocarbon solvents or fluids containing such solvents. • Many other fluids may contain chemicals that can react with aluminum. Contact your material supplier for compatibility. |
|    | <p>THERMAL EXPANSION HAZARD</p> <p>Fluids subjected to heat in confined spaces, including hoses, can create a rapid rise in pressure due to the thermal expansion. Over-pressurization can result in equipment rupture and serious injury.</p> <ul style="list-style-type: none"> • Open a valve to relieve the fluid expansion during heating. • Replace hoses proactively at regular intervals based on your operating conditions. |
|   | <p>MOVING PARTS HAZARD</p> <p>Moving parts can pinch, cut or amputate fingers and other body parts.</p> <ul style="list-style-type: none"> • Keep clear of moving parts. • Do not operate equipment with protective guards or covers removed. • Pressurized equipment can start without warning. Before checking, moving, or servicing equipment, follow the Pressure Relief Procedure and disconnect all power sources. |

Important Isocyanate (ISO) Information

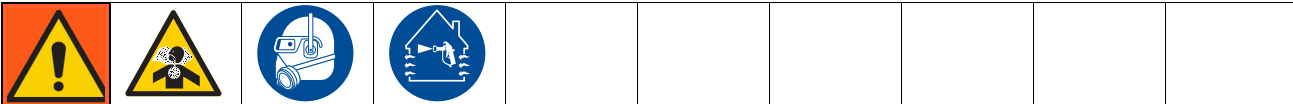

Isocyanates (ISO) are catalysts used in two-component materials.

Isocyanate Conditions





Spraying or dispensing fluids that contain isocyanates creates potentially harmful mists, vapors, and atomized particulates.

- Read and understand the fluid manufacturer’s warnings and Safety Data Sheet (SDS) to know specific hazards and precautions related to isocyanates.
- Use of isocyanates involves potentially hazardous procedures. Do not spray with this equipment unless you are trained, qualified, and have read and understood the information in this manual and in the fluid manufacturer’s application instructions and SDS.
- Use of incorrectly maintained or mis-adjusted equipment may result in improperly cured material which could cause off gassing and offensive odors. Equipment must be carefully maintained and adjusted according to instructions in the manual.
- To prevent inhalation of isocyanate mists, vapors and atomized particulates, everyone in the work area must wear appropriate respiratory protection. Always wear a properly fitting respirator, which may include a supplied-air respirator. Ventilate the work area according to instructions in the fluid manufacturer’s SDS.
- Avoid all skin contact with isocyanates. Everyone in the work area must wear chemically impermeable gloves, protective clothing and foot coverings as recommended by the fluid manufacturer and local regulatory authority. Follow all fluid manufacturer recommendations, including those regarding handling of contaminated clothing. After spraying, wash hands and face before eating or drinking.
- Hazard from exposure to isocyanates continues after spraying. Anyone without appropriate personal protective equipment must stay out of the work area during application and after application for the time period specified by the fluid manufacturer. Generally this time period is at least 24 hours.
- Warn others who may enter work area of hazard from exposure to isocyanates. Follow the recommendations of the fluid manufacturer and local regulatory authority. Posting a placard such as the following outside the work area is recommended:



| | |
|--|-------------------------------|
|  WARNING | |
|  | TOXIC FUMES HAZARD |
| DO NOT ENTER DURING SPRAY FOAM APPLICATION OR FOR ___ HOURS AFTER APPLICATION IS COMPLETE | |
| DO NOT ENTER UNTIL: | |
| DATE: _____ | |
| TIME: _____ | |

Material Self-ignition

| | | | | |
|---|---|--|--|--|
|  |  | | | |
|---|---|--|--|--|

Some materials may become self-igniting if applied too thick. Read material manufacturer's warnings and Safety Data Sheet (SDS).

Keep Components A and B Separate

| | | | | |
|---|---|---|--|--|
|  |  |  | | |
|---|---|---|--|--|

Cross-contamination can result in cured material in fluid lines which could cause serious injury or damage equipment. To prevent cross-contamination:

- **Never** interchange component A and component B wetted parts.
- Never use solvent on one side if it has been contaminated from the other side.

Moisture Sensitivity of Isocyanates

Exposure to moisture (such as humidity) will cause ISO to partially cure, forming small, hard, abrasive crystal that become suspended in the fluid. Eventually a film will form on the surface and the ISO will begin to gel, increasing in viscosity.

| NOTICE | | | | |
|--|--|--|--|--|
| Partially cured ISO will reduce performance and the life of all wetted parts. | | | | |
| <ul style="list-style-type: none"> • Always use a sealed container with a desiccant dryer in the vent, or a nitrogen atmosphere. Never store ISO in an open container. • Keep the ISO pump wet cup or reservoir (if installed) filled with appropriate lubricant. The lubricant creates a barrier between the ISO and the atmosphere. • Use only moisture-proof hoses compatible with ISO. • Never use reclaimed solvents, which may contain moisture. Always keep solvent containers closed when not in use. • Always lubricate threaded parts with an appropriate lubricant when reassembling. | | | | |

NOTE: The amount of film formation and rate of crystallization varies depending on the blend of ISO, the humidity, and the temperature.

Foam Resins with 245 fa Blowing Agents

Some foam blowing agents will froth at temperatures above 90°F (33°C) when not under pressure, especially if agitated. To reduce frothing, minimize preheating in a circulation system.



Changing Materials

| NOTICE | | | | |
|---|--|--|--|--|
| Changing the material types used in your equipment requires special attention to avoid equipment damage and downtime. | | | | |
| <ul style="list-style-type: none"> • When changing materials, flush the equipment multiple times to ensure it is thoroughly clean. • Always clean the fluid inlet strainers after flushing. • Check with your material manufacturer for chemical compatibility. • When changing between epoxies and urethanes or polyureas, disassemble and clean all fluid components and change hoses. Epoxies often have amines on the B (hardener) side. Polyureas often have amines on the B (resin) side. | | | | |

DataTrak Diagnostic Codes

DataTrak can diagnose several problems with the pump. When the monitor detects a problem, the LED will flash and a diagnostic code will appear on the display.

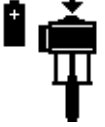
To acknowledge the diagnosis and return to the normal operating screen, press  once to wake up the display, and once more to clear the diagnostic code screen.

| Symbol | Code | Code Name | Diagnosis | Cause |
|---|------|-------------|---|---|
|  E2 | E-2 | Diving Down | Leak during downstroke. | Worn intake valve. |
|  E3 | E-3 | Low Battery | Battery voltage too low to stop runaway. | Low battery. Replace battery; see page 39. |
|  E6 Fuse 250mA | E-6 | Blown Fuse | Fuse is blown. Replace fuse; see page 39. | <ul style="list-style-type: none"> Faulty solenoid or solenoid wiring. Extreme temperatures (above 140°F [60°C]). |

Temperature Control Diagnostic Codes

Temperature control diagnostic codes appear on temperature display.

These alarms turn off heat. E99 clears automatically when communication is regained. Codes E03 through

E06 can be cleared by pressing . For other codes,

turn main power OFF  then ON  to clear.

| Code | Code Name | Alarm Zone |
|------|----------------------------------|------------|
| 01 | High fluid temperature | Individual |
| 02 | High zone current | Individual |
| 03 | No zone current | Individual |
| 04 | FTS or thermocouple disconnected | Individual |
| 05 | Control board over temperature | Individual |
| 06 | Communication cable unplugged | Individual |
| 30 | Momentary loss of communication | All |
| 99 | Loss of communication | All |

For hose zone only, if FTS is disconnected at startup, display will show hose current 0A.

E01: High fluid temperature

Causes of E01 Errors

- Thermocouple A or B (361) senses a fluid temperature above 230°F (110°C).
- Fluid temperature sensor (FTS) senses a fluid temperature above 230°F (110°C).
- Overtemperature switch (359) senses a fluid temperature above 230°F (110°C) and opens. At 190°F (87°C) the switch closes again.
- Thermocouple A or B (361) fails, is damaged, is not touching the heater element (358), or has a poor connection to the temperature control module.
- Overtemperature switch (359) fails in the open position.
- The temperature control module fails to turn off any heat zone.
- Zone power wires or thermocouples are switched from one zone to another.
- Failed heater element where thermocouple is installed.
- Loose wire
- Jumper wire covered in heat shrink in the wiring harness near the single over temperature switch connectors on the heater, is loose or incorrectly wired

Checks



Troubleshooting this equipment requires access to parts that may cause electric shock or other serious injury if work is not performed properly. Have a qualified electrician perform all electrical troubleshooting. Be sure to shut off all power to the equipment before repairing.

Check which zone is displaying the E01 error.

1. Check that connector B is firmly plugged into temperature control module (see FIG. 6, page 27).
2. Clean and re-plug connections.

3. Check connections between the temperature control module and over-temperature switch (359), and between temperature control module and thermocouples A and B (361) or FTS (21) [depending on which zone is displaying E01]. See Table 2, page 27. Ensure that all wires are securely connected to connector B.
4. Remove connector B from temperature control module, and check continuity of overtemperature switch, thermocouples A and B, or FTS by measuring resistance across the pins on the plug end; see Table 1.

Table 1: Sensor Connector Continuity Checks

| Pins | Description | Reading |
|---------|----------------|---|
| 1 & 2 | OT switch | nearly 0 ohms |
| 3 & 4 | Jumpered | nearly 0 ohms |
| 5 & 6 | Thermocouple A | 4-6 ohms |
| 8 & 9 | Thermocouple B | 4-6 ohms |
| 11 & 12 | FTS | approximately 35 ohms per 50 ft (15.2 m) of hose, plus approximately 10 ohms for FTS at 70°F (21°C) |
| 10 & 12 | FTS | open |

Before doing the following checks, note which zone (A, B, FTS, or all) has high fluid temperature.

5. Verify fluid temperature, using an external temperature sensing device.
 - **If temperature *is* too high (sensor reading is 229°F [109°C] or above):**
6. Check if thermocouples A and B are damaged, or not contacting the heater element, page 31.
7. To test that temperature control module turns off when equipment reaches temperature setpoint:
 - a. Set temperature setpoints far below displayed temperature.
 - b. Turn zone on. If temperature rises steadily, power module is failing.

- c. Verify by swapping with another power module. See **Replacing Temperature Control Assembly Modules**, page 28.
 - d. If the swapped module does not fix the problem, the power module is not the cause.
8. Verify continuity of heater elements with an ohmmeter, see page 29.

E02: High zone current



1. Turn main power OFF

2. Relieve pressure, page 14.

Disconnect whip hose.

3. Disconnect hose connector (D) at Reactor.
4. Using an ohmmeter, check between the two terminals of the connector (D). There should be no continuity.
5. Exchange zone module with another one. Turn zone on and check for error (see page 28). If error disappears, replace faulty module.

For hose zone: If error still occurs, perform **Transformer Primary Check** and **Transformer Secondary Check**, starting on page 34.

When there is a high current error, the LED on that zone's module will turn red while the error is displayed.

E03: No zone current

1. Check for tripped circuit breaker inside electrical cabinet or at power source for that zone. Replace circuit breaker if it trips habitually.
2. Check for loose or broken connection at that zone.
3. Exchange zone module with another one. Turn zone on and check for error (see page 28). If error disappears, replace faulty module.
4. If E03 occurs for all zones, the 238CR contactor may not be closing. Verify wiring from heater control to contactor coil.
 - a. *Hose zone:* test hose continuity, page 32.

- b. Perform **Transformer Primary Check** and **Transformer Secondary Check**, starting on page 34.

When a no current error occurs, the LED on this specific zone's module turns red when the error is displayed.

E04: Fluid Temperature Sensor (FTS) or thermocouple disconnected

1. Check temperature sensor connections to long green connector (B) on temperature control module, page 27. Unplug and re-plug sensor wires.
2. Test fluid temperature sensor continuity with ohmmeter, page 11.
3. If an error occurred for the hose zone, check FTS connections at each section of hose (see page 32).
4. If an error occurred for the hose zone, test FTS by plugging directly into machine.

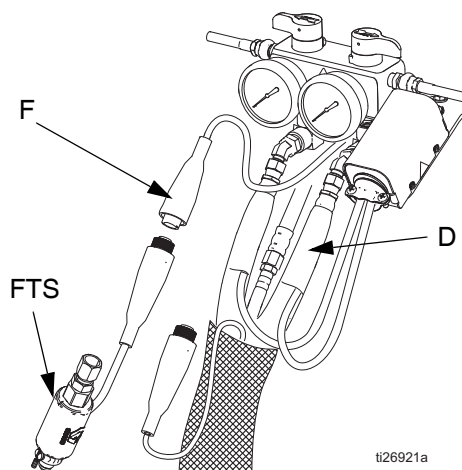

5. To verify heater control module is not causing the problem, use a wire to short-circuit the two pins corresponding to the FTS (red and yellow for A or B zone, red and purple for hose). The display will show the control heater module temperature.
6. If an error occurred for the hose zone, temporarily use manual current control mode. Refer to Reactor Operation manual.

E05: Control board over temperature

Each module has an on-board temperature sensor. Heat is turned off if module temperature exceeds 185°F (85°C) within the heater module.

1. Check that fan above electrical cabinet is operating.
2. Check that electrical cabinet door is properly installed.
3. Check for obstructions blocking cooling holes in bottom of electrical cabinet.
4. Clean heatsink fins behind heater control modules.
5. Ambient temperature may be too high. Allow Reactor to cool by moving to a cooler location.

E06: Communication cable unplugged

1. Unplug and re-plug cable that connects heater control module to heater module.
2. Replace communication cable if problem persists.

Communication Diagnostic Codes

E30: Momentary loss of communication

Communications between the display and the motor control board or the temperature control module have been momentarily lost. Normally, when communication is lost, the corresponding display will show E99. The corresponding control board will register E30 (The red LED will flash 30 times). If communications are reconnected, the display can show the E30 for a small time (no more than about two seconds). It should not be possible for E30 to be shown continuously, unless there is a loose connection causing the display and the board to continuously lose and regain communication.

Check all wiring between the display and the control board.

E99: Loss of communication

Communications between the display and the temperature control module has been lost. When communication is lost, the display will show E99.

1. Check all wiring between the display and the temperature control module. Pay close attention to the wire crimping on plug J13 for temperature display and connector for control module.



Step 2 measures line voltage and should be done by a qualified electrician. If work is not performed properly it may cause electric shock or other serious injury.

2. Measure the incoming voltage to the module (it should be ~ 200-240VAC).
3. If it was only receiving 1 leg of the 200-240Vac the board may light up, and still not function properly. Correct the incoming voltage problem.

Before Beginning Repair



Repairing this equipment requires access to parts that may cause electric shock or other serious injury if work is not performed properly. Electrical troubleshooting must be done by a qualified electrician. Be sure to shut off all power to equipment and lock out power at the source before repairing.

1. Flush if necessary. See **Flushing**, page 15.
2. Turn main heater power OFF .
3. Relieve pressure. See **Pressure Relief Procedure**.

Pressure Relief Procedure



The Fusion AP gun is shown.

1. Turn off feed pumps and agitator if used.
2. Park component A pump. Follow **Park**; see page 15.
3. Close the air inlet valve.
4. Engage gun piston safety lock.

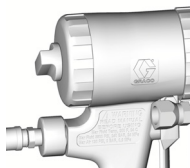

ti2409a

5. Close gun fluid inlet valves A and B.

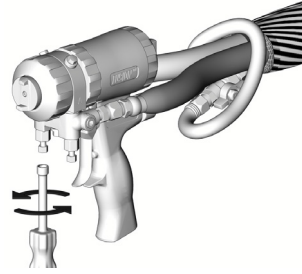

ti2421a

6. Close pump inlet supply valves.

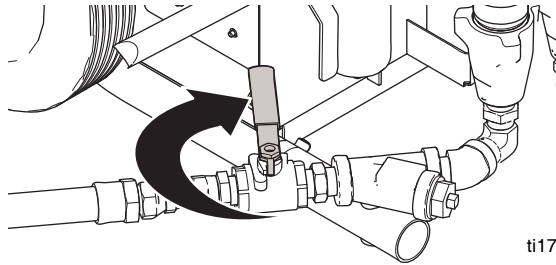

ti17716a

Shutdown

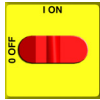
1. Turn main heater power OFF .
2. Follow **Park**.
3. Check and fill wet-cups (AK, Z).

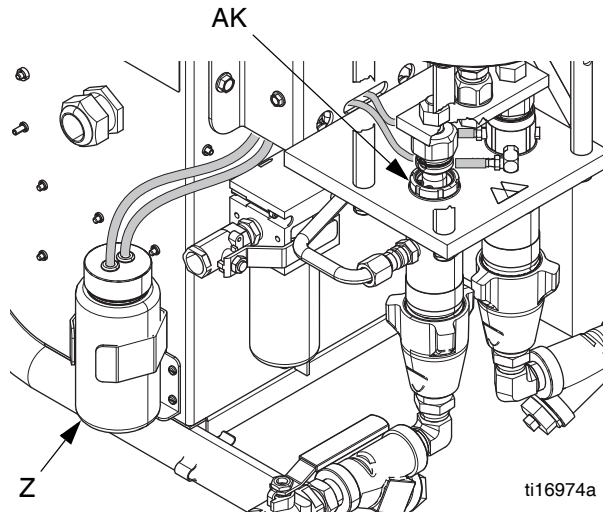

ti16974a

4. Follow gun shutdown procedure. See gun manual.

Park

Park the pumps at the end of the day to cycle component A pump to home position, submerging displacement rod.

1. Open the park valve.

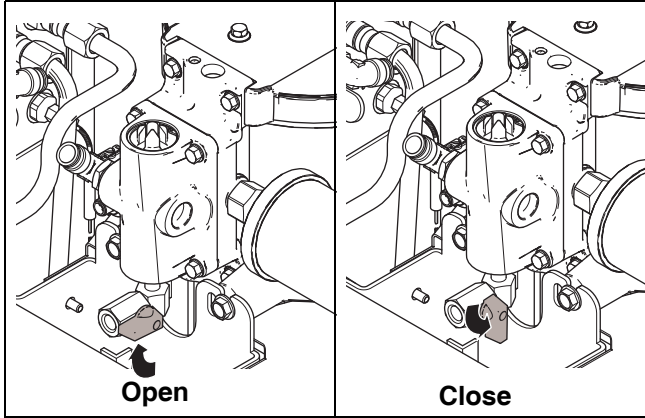

2. Trigger the gun until pumps stops at the bottom and relieves pressure.
3. Close the air motor shutoff valve.
4. Close the park valve.

Flushing

| | | | | |
|---|--|--|--|--|
| | | | | |
| Flush equipment only in a well-ventilated area. Do not spray flammable fluids. Do not turn on heaters while flushing with flammable solvents. | | | | |

- Flush out old fluid with new fluid, or flush out old fluid with a compatible solvent, such as toluene, naphtha, or mineral spirits solvent (also called white spirit) before introducing new fluid.
- Use lowest possible pressure when flushing.
- To flush feed hoses, pumps, and the heater separately from the heated hoses, set PRESSURE RELIEF/SPRAY valves (SA, SB) to PRESSURE RELIEF/CIRCULATION. Flush through bleed lines (N).

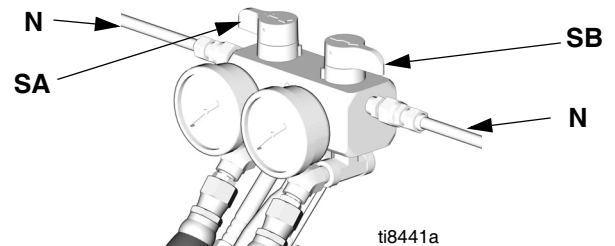

- To flush entire system, circulate through gun fluid manifold (with manifold removed from gun).
- Always leave hydraulic oil or a non-water based, non-water absorbent fluid in system. Do not use water.

| | | | | |
|--|--|--|--|--|
| | | | | |
| Only use flush solvents that are compatible with Fluoroelastomer seals. Non-compatible solvents will damage seals and cause hazardous conditions, such as high pressure leaks and pressure switch failure. | | | | |

Troubleshooting



Before performing any troubleshooting procedures:

1. Relieve pressure, page 14.

2. Turn main power OFF

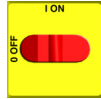

3. Allow equipment to cool.

Problems

Try the recommended solutions in the order given for each problem, to avoid unnecessary repairs. Also, determine that all circuit breakers, switches, and controls are properly set and wiring is correct before assuming there is a problem.

Power

| PROBLEM | CAUSE | SOLUTION |
|--|---|---|
| Heat zones do not operate | No power | Connect power cord Turn Main Disconnect Switch ON |
| | Power cord not connected properly | Check connections |
| No power when disconnect switch is turned on; using 200-240V, 1 phase or 200-240V, 3 phase power | Power terminal jumper still at 350-415V, 3 phase position, as shipped from factory | Place jumpers in correct position; see Operation manual and label inside front lower cabinet. |
| External main supply power circuit breaker trips and Reactor disconnect switch fails when switch is turned on. | Power terminal jumper was left in 200-240V, 1 phase position. When using 200-240V, 3 phase or 350-415V, 3 phase power | Place jumpers in correct position; see Operation manual. Replace main power disconnect switch; see page 41. |
| No temperature display lights at startup | No power | Connect power cord Turn Main Disconnect Switch ON |
| | Control power fuses blown | Check and replace fuses on long terminal strip |

Pumps and Pressures



| PROBLEM | CAUSE | SOLUTION |
|--------------------------------------|--|---------------------------------|
| Pump does not run up and down | Motor control valve closed | Open air motor shutoff valve |
| | No air supply | Air supply line not connected |
| | | Open inlet air ball valve |
| | Air pressure regulators set at 0 psi | Turn up air pressure regulators |
| Air motor shuttle valve is centered. | Push button on top of air motor shuttle valve. | |
| Pump runs but no fluid pressure | Fluid inlet ball valves closed | Open fluid inlet ball valves |

| PROBLEM | CAUSE | SOLUTION |
|---|---|---|
| Fluid pressure low or dropping | Air supply pressure low when spraying | Increase inlet air pressure |
| | | Increase air compressor size to meet flow requirements |
| | | Remove airline quick disconnects |
| | | Use 3/8 in. (0.95 cm) ID or larger air supply hose. Use 1/2 in. (12.7 mm) if longer than 25 ft (7.6 m). |
| | Icing in air motor exhausts or mufflers | Check inlet filter water separator; see page 26. Stop spraying while ice melts. |
| Pump output low, but pressure is normal | Obstructed gun impingement ports or filters | Flush and clean gun; see gun manual |
| One pressure gauge drops when pumps are stalled on both the upstroke and the downstroke | Leaking pump throat | Repair pump; see 309577 |
| | Leak between pump and gun | Check fluid tubes, heater, and hoses |
| | | Pressure Relief/Spray valve leaking back to supply |
| Spray gun is leaking on one side or plugged on the other side | Clean and repair spray gun | |
| One pressure gauge drops when pumps are stalled on the downstroke, but not the upstroke | Inlet ball check not sealing | Clean or replace; see 309577 |
| | Inlet check seat o-ring not sealing | Repair pump; see 309577 |
| One pressure gauge drops when pumps are stalled on the upstroke, but not the downstroke | Piston check ball not sealing | Repair pump; see 309577 |
| | Piston packing not sealing | Repair pump; see 309577 |
| | Loose piston stud in pump | Repair pump; see 309577 |
| | Bad inside sleeve seal | Repair o-ring; see 309577 |
| A side rich; lack of B side | A side gauge is low | B side restriction downstream of gauge. Check gun check valve screen, mix module, or mix manifold restrictor. |
| | | A side impingement port is worn. |
| | B side gauge is low | B side material supply problem. Check B side inlet strainer and pump intake valve. |
| B side rich; lack of A side | A side gauge is low | A side material supply problem. Check A side inlet strainer and pump intake valve. |
| | | A side restriction downstream of gauge. Check gun check valve screen, mix module, or mix manifold restrictor. |
| | B side gauge is low | B side impingement port is worn. |

| PROBLEM | CAUSE | SOLUTION |
|---|--|---|
| Fluid pressures not balanced between A and B side | Fluid viscosities not equal | Adjust A and B temperature settings to balance viscosity. Sometimes normal if pressure offset is below 200 psi (14 bar) Preheat material in drums by recirculating; see Operation manual |
| | Inlet Y-strainer screen plugged on low pressure side | Clean inlet filter screen |
| | Gun port or filter plugged on high pressure side | Clean or replace; see gun manual |
| | Pump inlet ball not seating or sticking | Clean seating; see pump manual |
| | Drum fluid outlet supply hose too small | Use 3/4 in. (1.9 cm) ID hose with short length |
| | Low side feed pump not working | Turn on or repair feed pump |
| | Pressure Relief/Spray valve leaking back to supply | |
| Pump does not reverse direction | Obstruction of air motor or pumps | Check and clear obstruction |
| Unequal fluid pressure between UP/DOWN stroke | Feed pumps boost pressure on up stroke. | Reduce feed pump pressures |
| Air motor doesn't move with air pressure applied | Damaged air valve | Replace or service air valve. See Air Motor manual. |
| | Damaged pilot valve | |
| | Park valve left open or leaking | Replace valve. See Air Motor manual. |
| Pump movement speed is erratic | Worn air motor seals | Replace seals. See Air Motor manual. |
| | Worn pump seals | Replace seals; see Pump manual. |

Electronics

| Problem | Cause | Solution |
|--|------------------------------------|---|
| Display does not illuminate. | No power. | Plug in power cord. Turn disconnect ON  |
| | Low voltage. | Ensure input voltage is within specifications, page 37. |
| | Loose wire. | Check connections, page 37. |
| | Display disconnected. | Check cable connections, page 37. |
| Temperature display does not illuminate. | Display disconnected. | Check cable connections, page 37. |
| | Display cable damaged or corroded. | Clean connections; replace cable if is damaged. |

| Problem | Cause | Solution |
|---|---|---|
| Erratic display; display turns on and off. | Low voltage. | Ensure input voltage is within specifications, page 37. |
| | Poor display connection. | Check cable connections, page 37. Replace damaged cable. |
| | Display cable damaged or corroded. | Clean connections; replace cable if is damaged. |
| | Display cable not grounded. | Ground cable, page 38. |
| | Display extension cable too long. | Must not exceed 100 ft (30.5 m) |
| Hose display reads OA at startup. | FTS disconnected or not installed. | Verify proper installation of FTS (see Operation manual), or adjust FTS to desired current setting. |
| Display does not respond properly to button pushes. | Poor display connection. | Check cable connections, page 37. Replace damaged cable. |
| | Display cable damaged or corroded. | Clean connections; replace cable if is damaged. |
| | Ribbon cable on display circuit board disconnected or broken. | Connect cable (page 37) or replace. |
| | Broken display button. | Replace, page 37. |
| No hose heat. | Loose hose electrical connections. | Check connections. Repair as necessary. |
| | Circuit breakers tripped. | Reset breakers (CB1 or CB2), page 35. |
| | Hose zone not turned on. | Press  zone  key. |
| | A and B temperature setpoints too low. | Check. Increase if necessary. |
| | Failed temperature control module. | Open cabinet. Check if board LED is blinking. If not, check power wiring connections to ensure module has power. If board has power and LED is not blinking, replace module, page 27. |
| Low hose heat. | A and B temperature setpoints too low. | Increase A and B setpoints. Hose designed to maintain temperature, not increase temperature. |
| | Hose temperature setpoint too low. | Check. Increase if necessary to maintain heat. |
| | Flow too high. | Use smaller mix chamber. Decrease pressure. |
| | Low current; FTS not installed. | Install FTS, see operation manual. |
| | Hose heat zone not turned on long enough. | Allow hose to heat up, or preheat fluid. |
| | Loose hose electrical connections. | Check connections. Repair as necessary. |

Heater



| PROBLEM | CAUSE | SOLUTION |
|--|---|--|
| Primary heater(s) does not heat. | Heat turned off. | Press A or B zone I keys. |
| | Temperature control alarm. | Check temperature display for diagnostic code, page 10. |
| | Signal failure from thermocouple. | See E04: Fluid Temperature Sensor (FTS) or thermocouple disconnected , page 12. |
| Control of primary heat is abnormal; high temperature overshoots or E01 error occurs intermittently. | Dirty thermocouple connections. | Examine connection of thermocouples to long green plug on heater control board. Unplug and re-plug thermocouple wires, cleaning off any debris. Unplug and re-plug long green connector. |
| | Thermocouple not contacting heater element. | Loosen ferrule nut (N), push in thermocouple (361) so tip (T) contacts heater element (358). Holding thermocouple tip (T) against heater element, tighten ferrule nut (N) 1/4 turn past tight. See page 31 for illustration. |
| | Failed heater element. | See Primary Heater , page 29. |
| | Signal failure from thermocouple. | See E04: Fluid Temperature Sensor (FTS) or thermocouple disconnected , page 12. |
| | Thermocouple wired incorrectly. | See E04: Fluid Temperature Sensor (FTS) or thermocouple disconnected , page 12. Power up zones one at a time and verify that temperature for each zone rises. |

Hose Heat System

| PROBLEM | CAUSE | SOLUTION |
|--|---|--|
| Hose heats but heats slower than usual or it does not reach temperature. | Ambient temperature is too cold. | Use auxiliary hose heat system. |
| | FTS failed or not installed correctly. | Check FTS, page 12. |
| | Low supply voltage. | Verify line voltage. Low line voltage significantly reduces power available to hose heat system, affecting longer hose lengths. |
| Hose does not maintain temperature while spraying. | A and B setpoints too low. | Increase A and B setpoints. Hose is designed to maintain temperature, not to increase it. |
| | Ambient temperature is too cold. | Increase A and B setpoints to increase fluid temperature and keep it steady. |
| | Flow too high. | Use smaller mix chamber. Decrease pressure. |
| | Hose was not fully preheated. | Wait for hose to heat to correct temperature before spraying. |
| | Low supply voltage. | Verify line voltage. Low line voltage significantly reduces power available to hose heat system, affecting longer hose lengths. |
| Hose temperature exceeds setpoint. | A and/or B heaters are overheating material. | Check primary heaters for either a thermocouple problem or a failed element attached to thermocouple, page 12. |
| | Faulty thermocouple connections. | Verify that all FTS connections are snug and that pins of connectors are clean. Examine connection of thermocouples to long green plug on heater control board. Unplug and re-plug thermocouple wires, cleaning off any debris. Unplug and re-plug long green connector on heater control board. |
| | Missing/damaged insulation around FTS, causing the hose heat to be ON constantly. | Make sure bundle has adequate insulation evenly covering the entire length and connection joints. |



| PROBLEM | CAUSE | SOLUTION |
|---|---|---|
| Erratic hose temperature. | Faulty thermocouple connections. | Verify that all FTS connections are snug and that pins of connectors are clean. Examine connection of thermocouples to long green plug on heater control board. Unplug and re-plug thermocouple wires, cleaning off any debris. Unplug and re-plug long green connector. |
| | FTS not installed correctly. | FTS should be installed close to end of hose in same environment as gun. Verify FTS installation, page 33. |
| | Missing/damaged insulation around FTS, causing the hose heat to be ON constantly. | Make sure bundle has adequate insulation evenly covering the entire length and connection joints. |
| Hose does not heat. | FTS failed or is not contacting correctly. | Check FTS, page 12. |
| | FTS not installed correctly. | FTS should be installed close to end of hose in same environment as gun. Verify FTS installation, page 33. |
| | Temperature control alarm. | Check temperature display or diagnostic code, page 33. |
| Hoses near Reactor are warm, but hoses downstream are cold. | Shorted connection or failed hose heating element. | <p>With hose heat on and temperature setpoint above displayed hose zone temperature, verify voltage between connectors at each section of hose.</p> <p>Voltage should drop incrementally for each section of hose further from Reactor. Use safety precautions when hose heat is turned on.</p> |

Repair

| | | | | |
|---|---|--|--|--|
|  |  | | | |
|---|---|--|--|--|

Unless otherwise noted, all repair procedures must be completed with incoming power switched OFF and locked out at the source. Any electrical repair or troubleshooting required beyond the scope of this manual must be performed by a qualified electrician. Shut off air inlet ball valve and shut off all air supply pressure.

Disconnect Pump

| | | | | |
|---|---|--|--|--|
|  |  | | | |
|---|---|--|--|--|

Air motor shaft, yoke, pump rod and connecting rod move during operation. Moving parts can cause serious injury such as pinching or amputation. Keep hands and fingers away from connecting rod during operation.

See manual 309577 for pump repair instructions.

1. Turn main heater power OFF 
2. Follow **Flushing**, page 15.
3. Follow **Pressure Relief Procedure**, page 14.
4. Follow **Park** instructions, page 15.
5. Shut off both feed pumps and close both inlet supply valves (F).

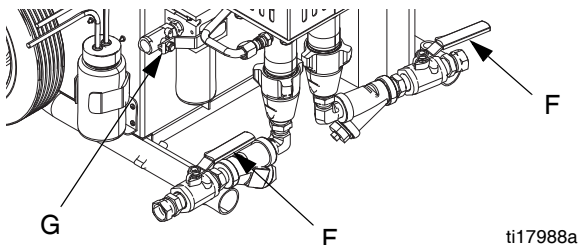

6. Shut off inlet air ball valve (G).
7. Remove screws (13, 15) and pump covers (63).

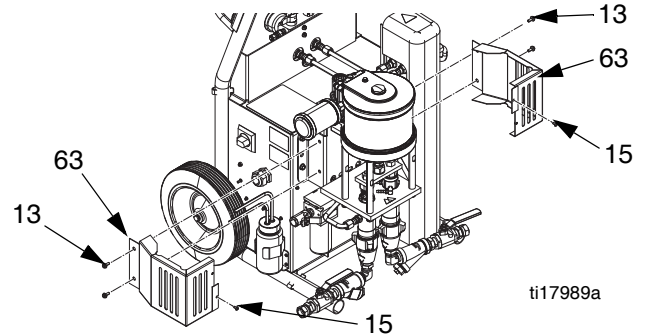

8. Disconnect A side (21) and B side (23) steel outlet tubes from adapters (312).

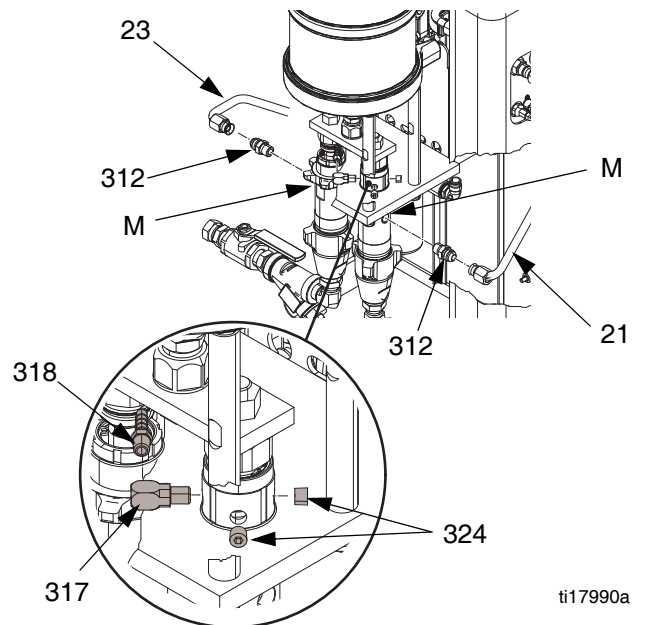

9. Remove adapter (312) from fluid outlet (M).
10. For A Side pump, disconnect barb fitting (318), elbow fitting (317), and two pipe plugs (324).

It is not necessary to cut tubes connected to barb fittings.

11. Push retaining wire clip (307) up. Push retaining pin (306) out.

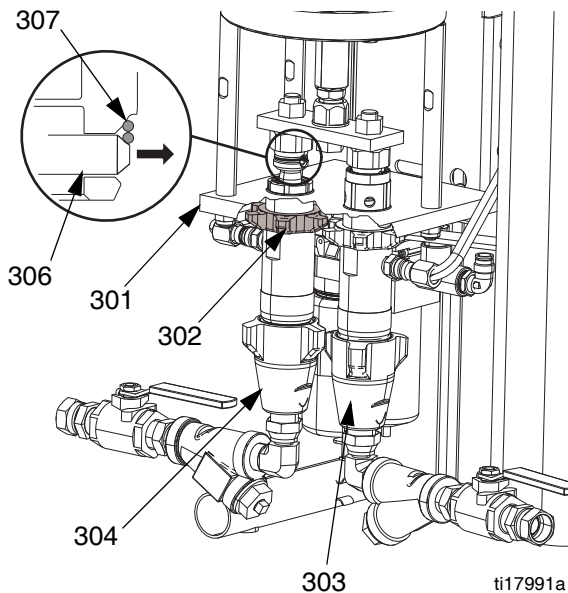

12. Loosen lock nut (302) by hitting firmly with a non-sparking hammer.
13. Unscrew pump out of pump mounting plate (301).
14. See pump manual for repair procedures and replacement parts.

Connect Pump

1. Ensure locknut (302) is screwed on pump with flat side up. Grease pump mounting threads in plate and pump cylinders (303, 304) with lithium grease. Screw pump into pump mounting plate (301) until top of pump thread is above mounting plate 1/2 to 1 1/2 threads above flush.

Pump rod connecting links (302) should be positioned so that pins (306) are in line with each other.

2. Align pump rod hole with link hole. Push retaining pin (306) in. Pull retaining wire clip (307) down to cover pin ends.
3. Tighten locknut (302) by hitting firmly with a non-sparking hammer.
4. Install adapter (312) in fluid outlet. Connect A side (21) and B side (23) steel outlet tubes.
5. For Iso A pump only:
 - a. Install two pipe plugs (324).
 - b. Reconnect two tubing lines (N) from ISO Pump Lube reservoir. Flush and refill reservoir with TSL 206995.
6. Refill Resin B pump wet cup with TSL 206995.

Remove Air Motor

1. Press in tube fitting ferrules and pull out tubing (65) to disconnect air line.
2. Disconnect DataTrak communication cable, if installed.
3. Place wrench on adapter (315) and a another wrench on lock nut (313). Remove lock nut (313).

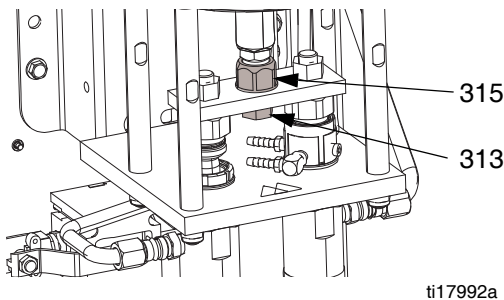

FIG. 1

4. Remove four nuts (310) from tie rods (309).

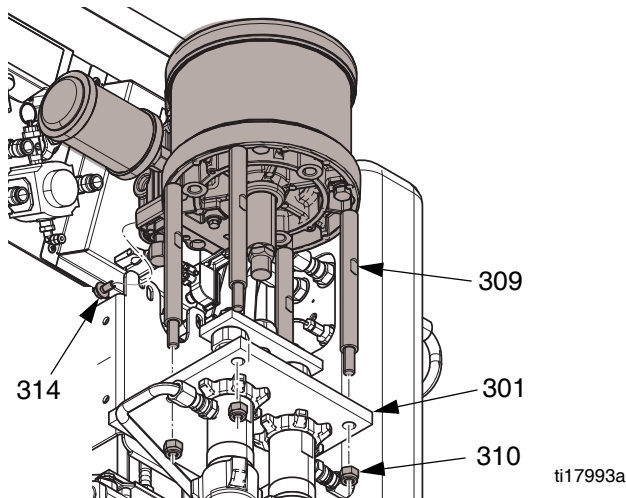

FIG. 2

5. Loosen two screws (314) behind air motor bracket. Carefully lift air motor and tie rods away from the proportioner frame and plate (301).

6. Lay air motor on a clean flat work space. Place a wrench on the tie rod flats (309) and hold one of other tie rods with your hand to keep the air motor (308) in place. Remove the tie rods from the air motor.

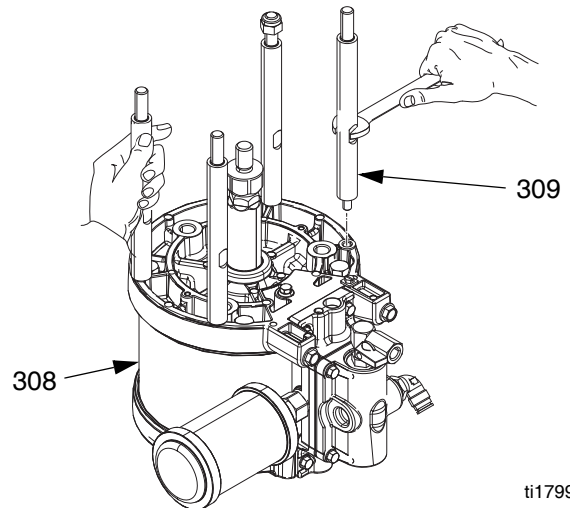

FIG. 3

7. Use a wrench to hold the piston rod in place and remove the adapter (315) with another wrench. See FIG. 1.
8. See air motor manual for repair instructions.

Install Air Motor

1. Apply medium blue thread lock on adapter (315). Use a wrench to hold the piston rod in place and install the adapter (315) with another wrench. Torque to 32-38 ft-lbs (43-51 N•m). See FIG. 1.
2. Install tie rods (309) in the bottom of the air motor (308). See FIG. 3.
3. Install tie rods through plate (301). Ensure screws (314) fit in the bracket slots (311). Install screws (314). See FIG. 2.
4. Tighten nut (313) to 32-38 ft-lbs (43-51 N•m).
5. Evenly torque four tie rod nuts (310) in small increments to 27-32 ft-lbs (37-43N•m). See FIG. 2.

Recirculation / Over Pressure Relief Block

Valves can be serviced with the block on the machine (see page 47 for parts view). For thorough cleaning, remove the block assembly as follows.

1. Disconnect two fluid tubes connected to back of recirculation block (3).
2. Loosen and remove two screws (10) in back of recirculation block.

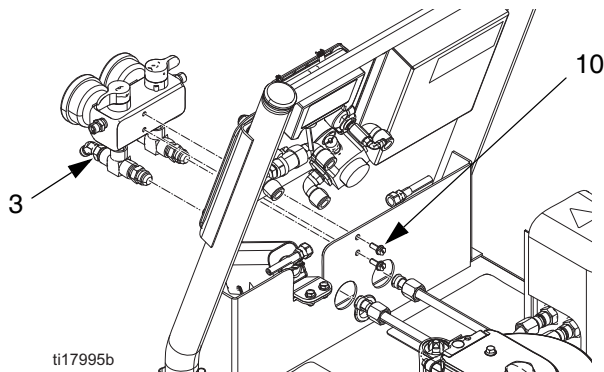

FIG. 4

3. See **Fluid Manifold**, page 47. Clean and inspect all parts for damage. Ensure that the seat (8a) and gasket (8b) are positioned inside each valve cartridge (8).
4. Apply PTFE pipe sealant to all tapered pipe threads before reassembling.
5. Reassemble in reverse order, following all notes on page 47.

Air Inlet Filter / Water Separator (Auto Drain)

Air Filter Element Removal

1. Close air inlet valve (302) on filter (301).
2. Hold in metal spring clip and twist black cover counterclockwise to remove.

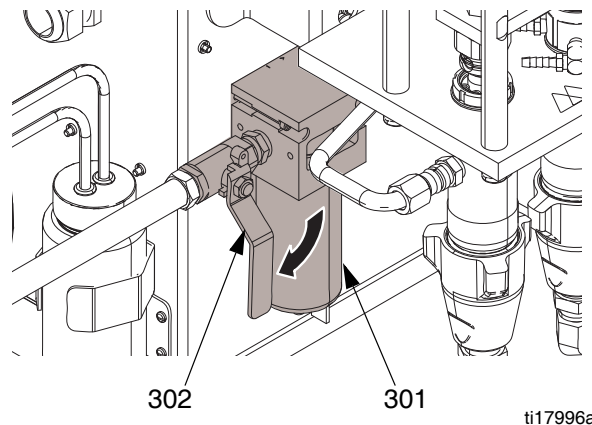

FIG. 5

3. Unscrew clear drain cover by hand.
4. Unscrew black filter element retainer to remove element.
5. Inspect filter element. Clean or replace.

Air Filter Element Installation

1. Insert cleaned or replacement filter (15D909).
2. Hand-screw filter retainer into place.
3. Hand-screw clear drain cover until tight.
4. Reposition black cover and turn. Make sure it "snaps" back into place.

Temperature Control Module

Table 2: Temperature Control Module Connections

| Connector | | Description |
|-------------------|--------------------------|---|
| DISPLAY (C) | | Display |
| SENSOR (B) | PIN | |
| | 1, 2 | OVERTEMPERATURE A; Overtemperature switch A |
| | 3, 4 | OVERTEMPERATURE B; Overtemperature switch B |
| | 5 | HEATER T/C A, R; Thermocouple (red) |
| | 6 | HEATER T/C A, Y; Thermocouple (yellow) |
| | 7 | Not used |
| | 8 | HEATER T/C B, R; Thermocouple (red) |
| | 9 | HEATER T/C B, Y; Thermocouple (yellow) |
| | 10 | HOSE T/C S; FTS (silver unshielded bare wire) |
| | 11 | HOSE T/C R; FTS (red) |
| 12 | HOSE T/C P; FTS (purple) | |
| DATA A | | Data Reporting |
| POWER/RELAY (G) | | Communication to power input and contactor control output |
| BOOT (F) | | Software bootloader |
| PROGRAM (E) | | Software programming |
| COMMUNICATION (D) | | Communication to power boards |

Table 3: Temperature Control Module Connections

| Connector | Description |
|-------------------|--------------------------------|
| COMMUNICATION (H) | Communication to control board |
| POWER (J) | Power to heater |

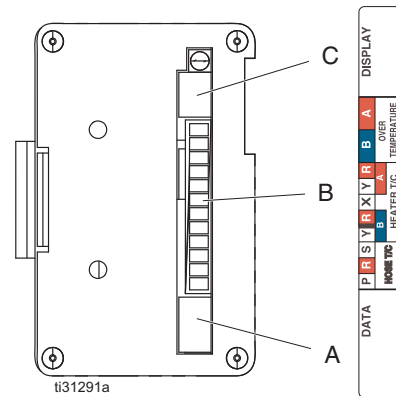
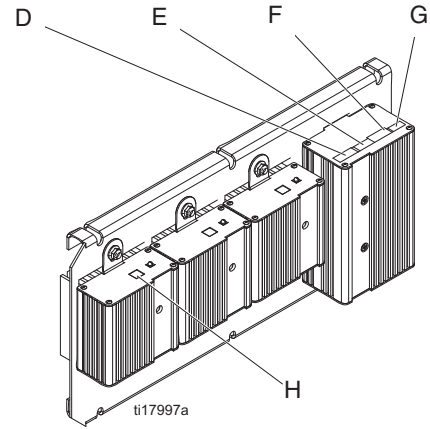

Right Side of Control Heater Module

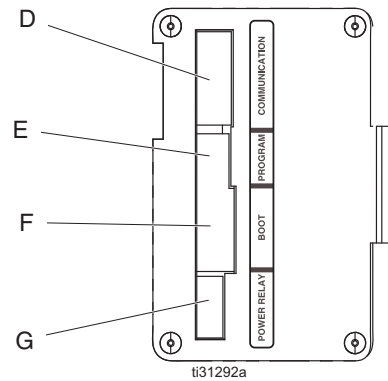



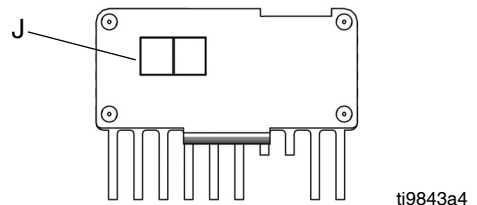

Left Side of Control Heater Module





Right Side of Power Modules

FIG. 6: Temperature Control Module Connections

Test SCR Circuit

1. Test the SCR circuit in the on position:
 - a. Make sure everything is connected, including the hose.
 - b. Turn main power ON  .
 - c. Adjust the hose heat setpoint **above** the ambient hose temperature.
 - d. Turn on  heat zone by pressing  .
 - e. Hold down  to view electrical current.
 Hose current should ramp up to 45A. If there is no hose current, see **E03: No zone current**, page 12. If hose current exceeds 45A, see **E02: High zone current**, page 12. If hose current stays several amps below 45A, hose is too long or voltage is too low.

2. Test the SCR circuit in the off position:
 - a. Make sure everything is connected, including the hose.
 - b. Turn main power ON  .
 - c. Adjust the hose heat setpoint **below** the ambient hose temperature.
 - d. Turn on  heat zone by pressing  .

Using a voltmeter, carefully measure the voltage at the hose connector. You should not get a voltage reading. If you do, the SCR on the temperature control module is bad. Replace the temperature control assembly.

Replacing Temperature Control Assembly Modules

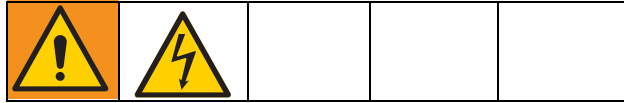





NOTICE

Before handling assembly, put on static conductive wrist strap to protect against static discharge which can damage assembly. Follow instructions provided with wrist strap.

1. Turn main power off  . Disconnect power supply.
2. Relieve pressure, page 14.
3. Refer to electrical diagrams. See **Reactor A-25/A-XP1 Wiring Schematic**, page 52. Temperature control assembly is on left side inside cabinet.
4. Remove bolts that secure transformer assembly and slide assembly to side in cabinet.
5. Put on static conductive wrist strap.
6. Disconnect all cables and connectors from assembly. See **Temperature Control Module**, page 27.
7. Remove nuts and take entire temperature control assembly to workbench.
8. Replace defective module.
9. Install assembly in reverse order.

Primary Heater

| | | | | |
|---|---|---|---|--|
|  |  |  |  | |
| Read Warnings on page 5. Wait for heater to cool before repairing. | | | | |

Line Voltage

The primary heaters output their rated wattage at 230 Vac. Low line voltage will reduce power available and the heaters will not perform at full capability.

Heater Element

1. Turn main power OFF . Disconnect power supply.
2. Relieve pressure, page 14.
3. Wait for heaters to cool.
4. Remove heater shroud.
5. See FIG. 7. Disconnect heater element wires from heater wire connector. Test with ohmmeter.

| Heater Rod Element Wattage | Ohms |
|----------------------------|-------|
| 1500 | 30-35 |

6. To remove heater element, first remove thermocouple (361) to avoid damage, see step 7, page 31.
7. Remove heater element (358) from housing (351). Be careful not to spill any fluid left in housing.
8. Inspect element. It should be relatively smooth and shiny. If there is a crusted, burnt, ash-like material adhered to element or sheath shows pitting marks, replace element.
9. Install new heater element (358), holding mixer (360) so it does not block thermocouple port (P).
10. Reinstall thermocouple, page 31.
11. Reconnect heater element leadwires to heater wire connector.
12. Replace heater shroud.

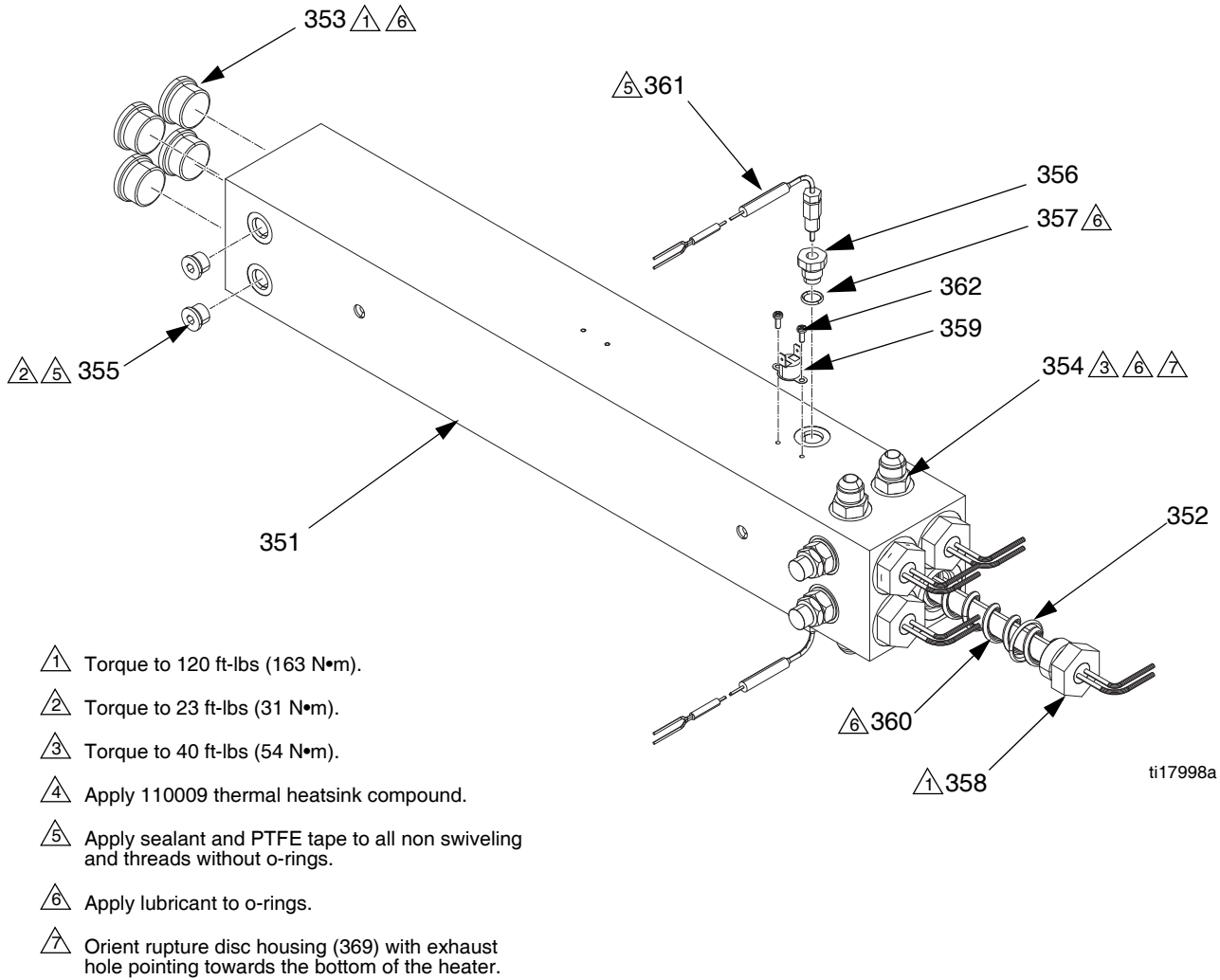
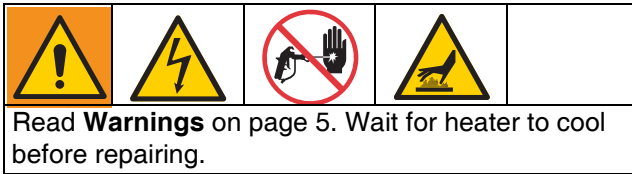

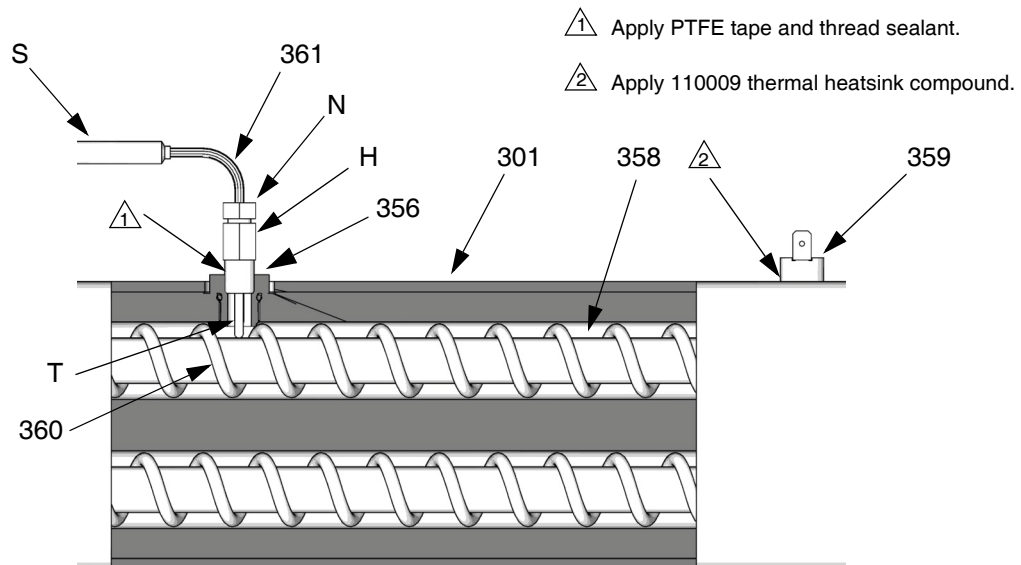

FIG. 7. 6 or 10 kW Dual Zone Heater

Thermocouple



1. Turn main power OFF . Disconnect power supply.
2. Relieve pressure, page 14.
3. Wait for heaters to cool.
4. Remove heater shroud.
5. Disconnect thermocouple wires from B on temperature control module. See Table 2, page 27 and FIG. 6, page 27.
6. Feed thermocouple wires out of cabinet. Note path as wires must be replaced in the same way.
7. See FIG. 8. Loosen ferrule nut (N). Remove thermocouple (361) from heater housing (351), then remove thermocouple housing (H). Do not remove the thermocouple adapter (356) unless necessary. If adapter must be removed, ensure that mixer (360) is out of the way when replacing the adapter.
8. Replace thermocouple, FIG. 8.
 - a. Remove protective tape from thermocouple tip (T).
 - b. Apply PTFE tape and thread sealant to male threads and tighten thermocouple housing (H) into adapter (356).
 - c. Push in thermocouple (361) so tip (T) contacts heater element (358).
 - d. Holding thermocouple (T) against heater element, tighten ferrule nut (N) 1/4 turn past tight.
9. Route wires (S) into cabinet and thread into bundle as before. Reconnect wires to board.
10. Replace heater shroud.
11. Turn on heaters A and B simultaneously to test. Temperatures should rise at same rate. If one heater is low, loosen ferrule nut (N) and tighten thermocouple housing (H) to ensure thermocouple tip (T) contacts element (358).



ti7924a

FIG. 8. Thermocouple

Overtemperature Switch

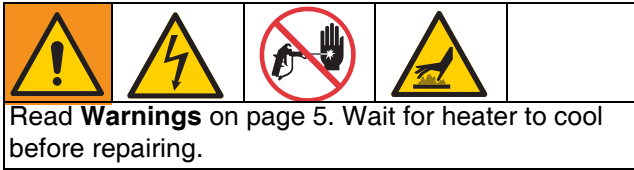

1. Turn main power OFF . Disconnect power supply.
2. Relieve pressure, page 14.
3. Wait for heaters to cool.
4. Remove heater shroud.
5. Disconnect one leadwire from over-temperature switch (359), FIG. 8. Test across switch with ohmmeter. Resistance must be approximately 0 ohms.
6. If switch fails test, remove wires and screws. Discard failed switch. Apply thermal compound 110009, install new switch in same location on housing (351), and secure with screws (311). Reconnect wires.

If wires need replacement, disconnect temperature control module. See Table 2, page 27 and FIG. 6, page 27

Heated Hose

Refer to the heated hose manual for hose replacement parts.

Check Hose Power Connectors

1. Turn main power OFF . Disconnect power supply.
2. Relieve pressure, page 14.

NOTE: Whip hose must be connected.

3. Disconnect Reactor power harness (PH) from hose termination box terminal block (TB).

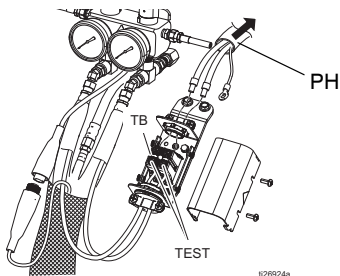

4. **For Series A only:** Disconnect hose connector (D) at Reactor.

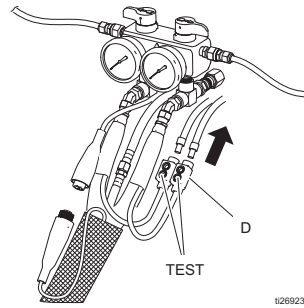

5. Using an ohmmeter, check between the two terminals of the connector (TEST). There should be continuity.
6. If hose fails test, retest at each length of hose, including whip hose, until failure is isolated.

Check FTS Cables

1. Turn main power OFF . Disconnect power supply.
2. Relieve pressure, page 14.
3. Disconnect FTS cable (F) at Reactor, FIG. 9.

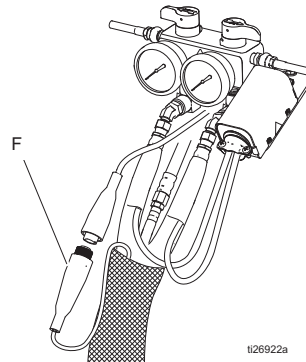

FIG. 9. Heated Hose

4. Test with ohmmeter between pins of cable connector.

| Pins | Result |
|--------|--|
| 1 to 2 | approximately 35 ohms per 50 ft (15.2 m) of hose, plus approximately 10 ohms for FTS |
| 1 to 3 | infinity |

5. If cable fails test, retest at FTS, page 33.

Fluid Temperature Sensor (FTS)

Test/Removal

1. Turn main power OFF . Disconnect power supply.
2. Relieve pressure, page 14.
3. Remove tape and protective covering from FTS. Disconnect hose cable (F). Test with ohmmeter between pins of cable connector.

| Pins | Result |
|------------------------------------|-----------------------|
| 1 to 2 | approximately 10 ohms |
| 1 to 3 | infinity |
| 3 to FTS groundscrew | 0 ohms |
| 1 to FTS component A fitting (ISO) | infinity |

4. If FTS fails any test, replace FTS.
5. Disconnect air hoses (C, L), and electrical connectors (D).
6. Disconnect FTS from whip hose (W) and fluid hoses (A, B).
7. Remove ground wire (K) from ground screw on underside of FTS.
8. Remove FTS probe (H) from component A (ISO) side of hose.

Installation

The Fluid Temperature Sensor (FTS) is supplied. Install FTS between main hose and whip hose. See Heated Hose manual 309572 for instructions.

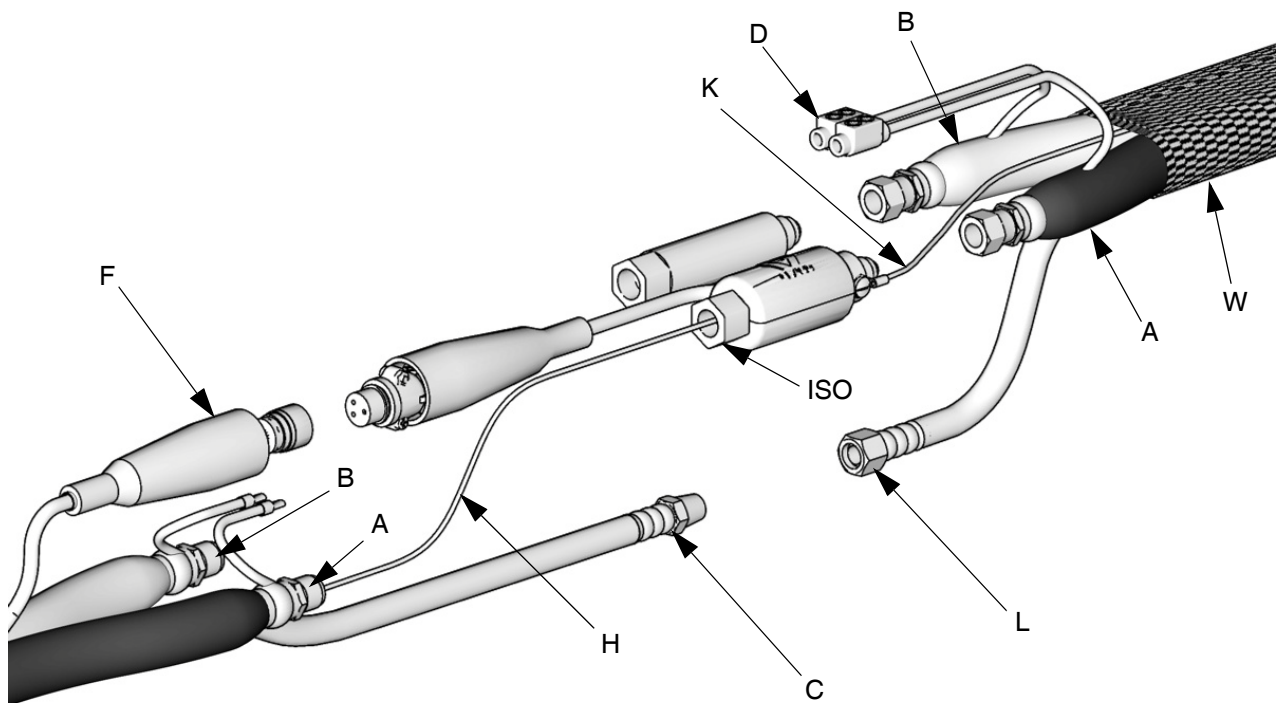

ti9581c

FIG. 10: Fluid Temperature Sensor and Heated Hoses

Transformer Primary Check

1. Turn main power OFF .
2. Locate the two smaller (10 AWG) wires coming out of transformer. Trace these wires back to contactor and circuit breaker (911). Use an ohmmeter to test for continuity between two wires; there should be continuity.

Transformer Secondary Check

1. Turn main power OFF .
2. Locate the two larger (6 AWG) wires coming out of transformer. Trace these wires back to large green connector under hose control module and circuit breaker (909). Use an ohmmeter to test for continuity between two wires; there should be continuity.

If you are not sure which wire in green plug under hose module connects to transformer, test both wires. One wire should have continuity with the other transformer wire in breaker (909) and the other wire should not.

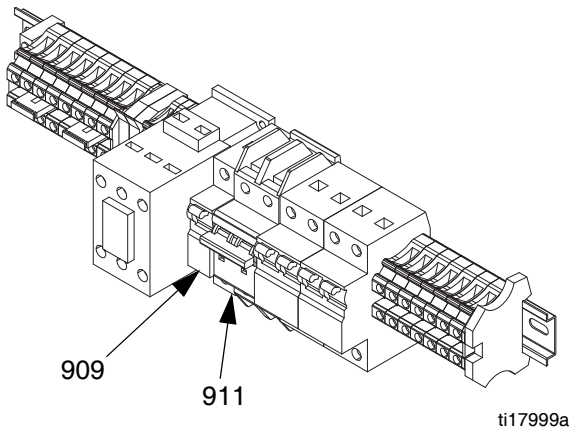

FIG. 11: Circuit Breaker Module

3. To verify transformer voltage, turn on hose zone. Measure voltage from 178CB-2 to HPOD-1; see **Reactor A-25/A-XP1 Wiring Schematic**, page 52.

| Model | Secondary Voltage |
|---------|-------------------|
| 310 ft. | 90 Vac* |
| 210 ft. | 62 Vac* |

* For 230 Vac line voltage.

Replace Transformer

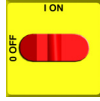

1. Turn main power OFF . Disconnect power supply.
2. Open Reactor cabinet.
3. Remove bolts holding transformer to cabinet floor. Slide transformer forward.
4. Disconnect the transformer wires; see **Reactor A-25/A-XP1 Wiring Schematic**, page 52.
5. Remove transformer from cabinet.
6. Install new transformer in reverse order.

Replace Circuit Breaker Module

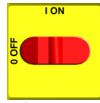

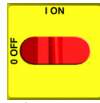
1. Turn main power OFF . Disconnect power supply. Turn circuit breakers on to test.
2. Relieve pressure, page 14.
3. Using an ohmmeter, check for continuity across circuit breaker (top to bottom). If no continuity, trip breaker, reset, and retest. If still no continuity, replace breaker as follows:
 - a. Refer to electrical diagrams and table below. Disconnect wires and remove bad breaker.

To reference cables and connectors, see the electrical diagrams and parts drawings on page 50 and 52.

- b. Install new breaker and reconnect wires.

| Ref. | Size | | Component |
|------|------|-------|-------------------------|
| | A-25 | A-XP1 | |
| CB1 | 50 A | 50 A | Hose Secondary (single) |
| CB2 | 40 A | 30 A | Hose Primary (double) |
| CB3 | 25 A | 30 A | Heater A (double) |
| CB4 | 25 A | 30 A | Heater B (double) |

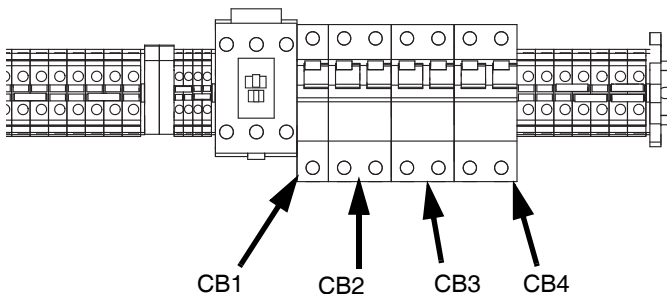

FIG. 12

Pump Lubrication System



Check the condition of the ISO pump lubricant daily. Change the lubricant if it becomes a gel, its color darkens, or it becomes diluted with isocyanate.

Gel formation is due to moisture absorption by the pump lubricant. The interval between changes depends on the environment in which the equipment is operating. The pump lubrication system minimizes exposure to moisture, but some contamination is still possible.

Lubricant discoloration is due to continual seepage of small amounts of isocyanate past the pump packings during operation. If the packings are operating properly, lubricant replacement due to discoloration should not be necessary more often than every 3 or 4 weeks.

To change pump lubricant:

1. Relieve pressure, page 14.
2. Lift the lubricant reservoir (LR) out of the bracket (RB) and remove the container from the cap. Holding the cap over a suitable container, remove the check valve and allow the lubricant to drain. Reattach the check valve to the inlet hose (ST). See FIG. 13.
3. Drain the reservoir and flush it with clean lubricant.
4. When the reservoir is flushed clean, fill with fresh lubricant.
5. Thread the reservoir onto the cap assembly and place it in the bracket.
6. The lubrication system is ready for operation. No priming is required.

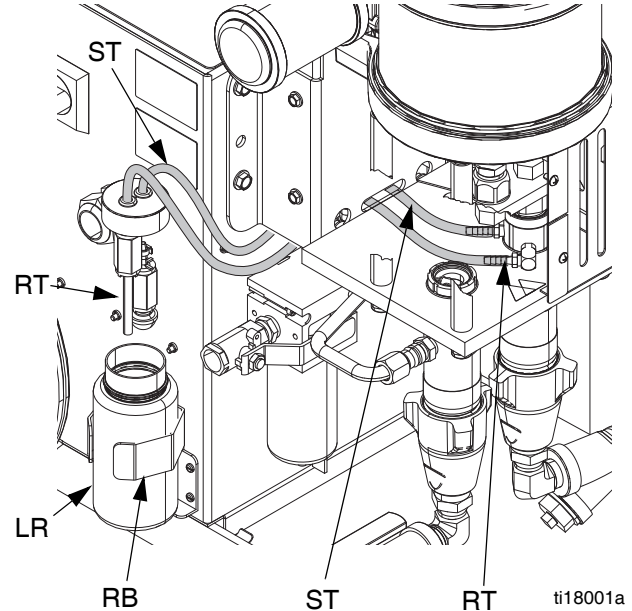

FIG. 13. Pump Lubrication System

Fluid Inlet Strainer Screen



The inlet strainers filter out particles that can plug the pump inlet check valves. Inspect the screens daily as part of the startup routine, and clean as required.

Isocyanate can crystallize from moisture contamination or from freezing. If the chemicals used are clean and proper storage, transfer, and operating procedures are followed, there should be minimal contamination of the A-side screen.

Clean the A-side screen only during daily startup. This minimizes moisture contamination by immediately flushing out any isocyanate residue at the start of dispensing operations.

1. Close the fluid inlet valve at the pump inlet and shut off the appropriate feed pump. This prevents material from being pumped while cleaning the screen.
2. Place a container under the strainer base to catch drain off when removing the strainer plug (C).
3. Remove the screen (A) from the strainer manifold. Thoroughly flush the screen with compatible solvent and shake it dry. Inspect the screen. No more than 25% of the mesh should be restricted. If more than 25% of the mesh is blocked, replace the screen. Inspect the gasket (B) and replace as required.
4. Ensure the pipe plug (D) is screwed into the strainer plug (C). Install the strainer plug with the screen (A) and gasket (B) in place and tighten. Do not over-tighten. Let the gasket make the seal.
5. Open the fluid inlet valve, ensure that there are no leaks, and wipe the equipment clean. Proceed with operation.

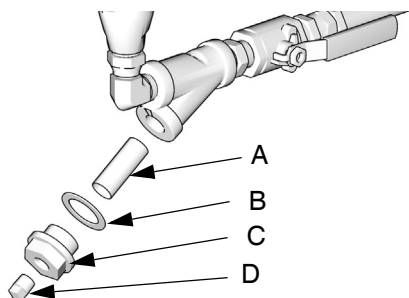

Ti10974a

Fig. 14. Fluid Inlet Strainer

Temperature Display



NOTICE

Before handling board, put on static conductive wrist strap to protect against static discharge which can damage assembly. Follow instructions provided with wrist strap.

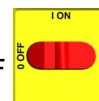

1. Turn main power OFF. Disconnect power supply.
2. Relieve pressure, page 14.
3. Refer to **Reactor A-25/A-XP1 Wiring Schematic**, page 52.
4. Put on static conductive wrist strap.
5. Disconnect main display cable (106) at lower left corner of display module; see FIG. 15.
6. Remove screws (116) and cover (105); see FIG. 15.
7. Disconnect cable connector from back of temperature display (102). See FIG. 15.
8. Disconnect ribbon cable(s) (R) from back of display; see FIG. 15.
9. Remove nuts (103) and plate (101).
10. Disassemble display, see detail in FIG. 15.
11. Replace board (102a) or membrane switch (102b) as necessary.
12. Reassemble in reverse order, see FIG. 15. Apply medium strength thread sealant where shown. Be sure display cable ground wire (G) is secured between cable bushing and cover (105) with screws (107).

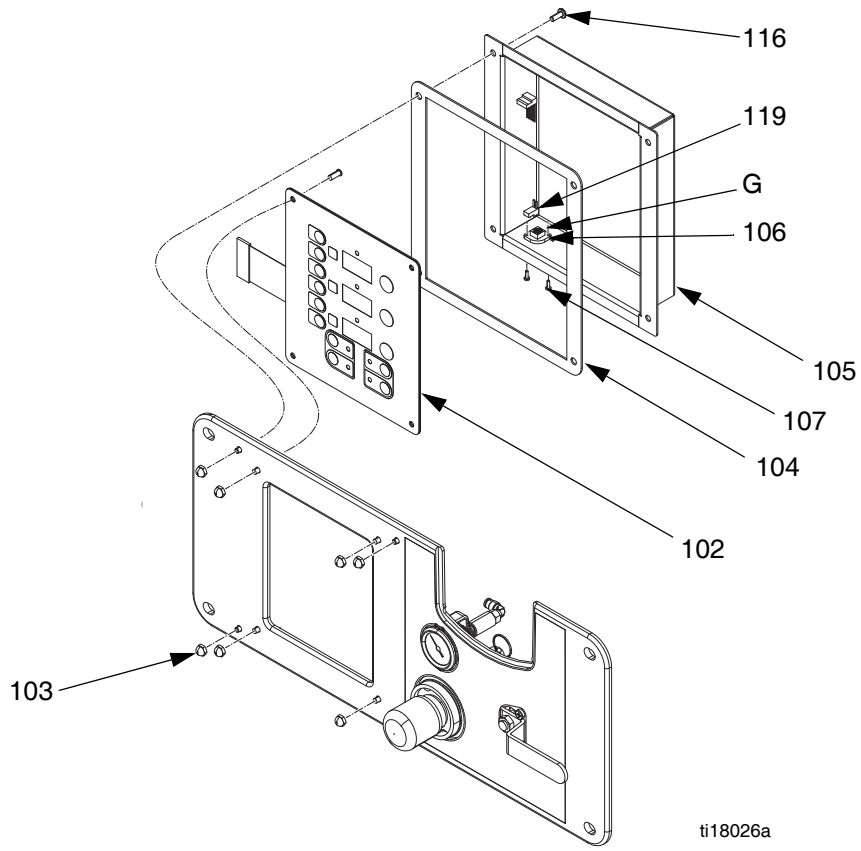

Detail of Membrane Switches and Temperature Display Board

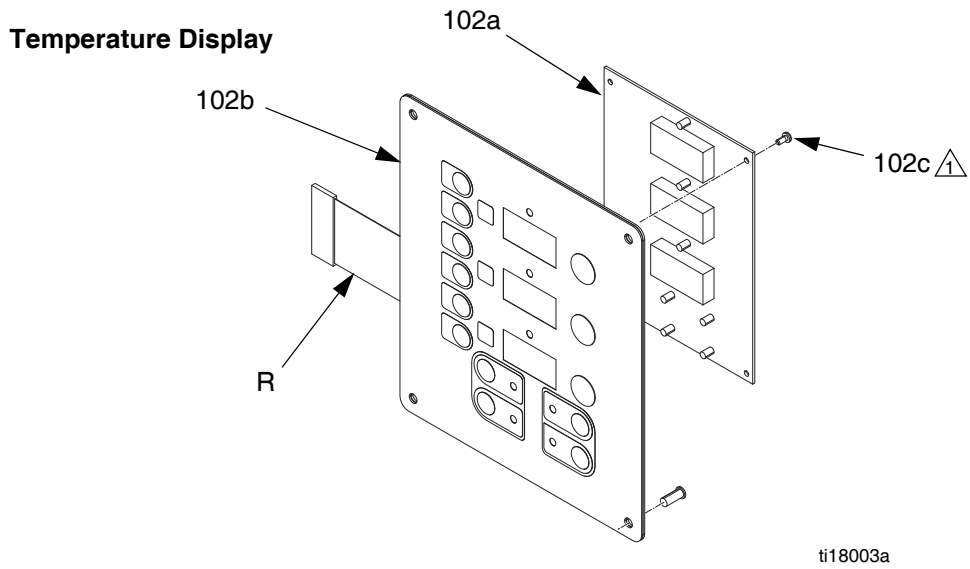



FIG. 15. Display Module

Replace DataTrak Battery or Fuse

| | | | | |
|---|---|--|--|--|
|  |  | | | |
|---|---|--|--|--|

The battery and fuse must be replaced in a non-hazardous location.

Use only the following approved replacement batteries. Use of an unapproved battery will void Graco's warranty and FM and Ex approvals.

- Ultralife lithium # U9VL
- Duracell alkaline # MN1604
- Energizer alkaline # 522
- Varta alkaline # 4922

Use only a Graco-approved replacement fuse. Order Part 24C580.

Replace Battery

1. Unscrew cable from the back of the reed switch assembly. See FIG. 16.
2. Remove the cable from the two cable clips.

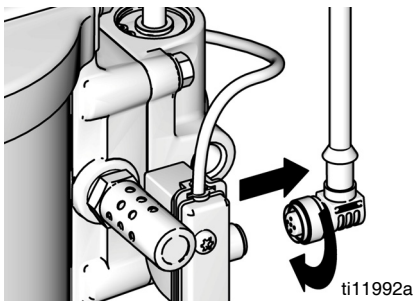

FIG. 16. Disconnect DataTrak

3. Remove DataTrak module from bracket. See FIG. 17. Take module and attached cable to a non-hazardous location.

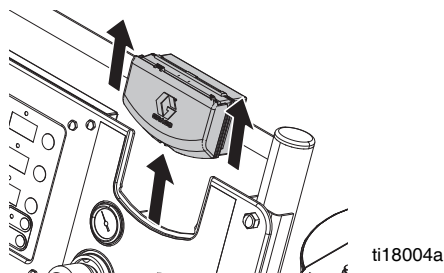

FIG. 17. Remove DataTrak

4. Remove two screws on back of module to access battery.
5. Disconnect the used battery and replace with an approved battery. See FIG. 18.

Replace Fuse

1. Remove the screw, metal strap, and plastic holder.
2. Pull the fuse away from the board.
3. Replace with a new fuse.

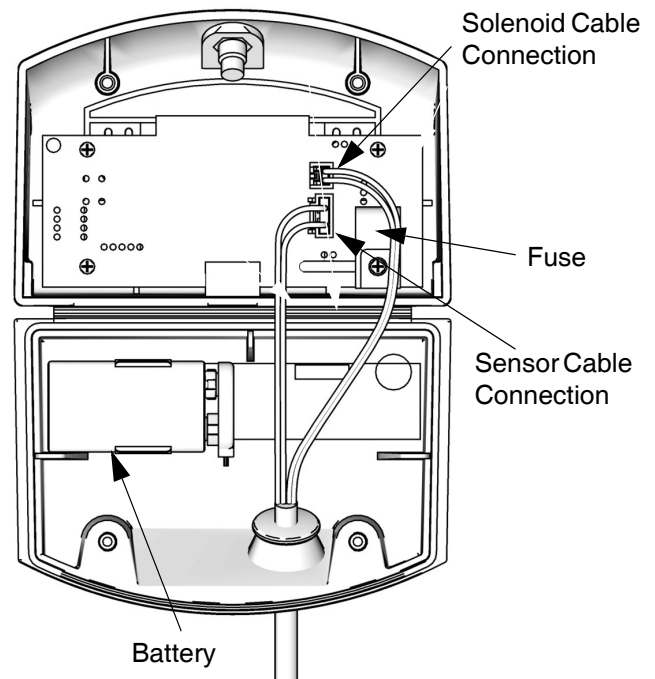

FIG. 18. DataTrak Battery and Fuse Location

Accessories

Feed Pump Kits

Pumps, hoses, and mounting hardware to supply fluids to Reactor. Includes 246483 Air Supply Kit. See 309815.

246483 Air Supply Kit

Hoses and fittings to supply air to feed pumps, agitator, and gun air hose. Included in feed pump kits. See 309827.

246978 Circulation Kit

Return hoses and fittings to make circulation system. Includes two 246477 Return Tube Kits. See 309852.

246477 Return Tube Kit

Desiccant dryer, return tube, and fittings for one drum. Two included in 246978 Circulation Kit. See 309852.

TSL (Throat Seal Liquid)

206995 1 qt (1 liter) bottle

206996 1 gal. (3.8 liter) container

24A592 DataTrak with Cycle Count Only Kit

DataTrack and reed switch for NXT Air Motor. See manual 313541.

Heated Hoses

A-25: 2000 psi (14 MPa, 138 bar)

A-XP1: 3500 psi (24 MPa, 241 bar)

50 ft (15.2 m) and 25 ft (7.6 m) lengths, 1/4 in. (6 mm), 3/8 in. (10 mm), or 1/2 in. (13 mm) diameter, 2000 psi (14 MPa, 140 bar) or 3500 psi (24 MPa, 241 bar). See 309572.

Heated Whip Hoses

A-25: 2000 psi (14 MPa, 138 bar)

A-XP1: 3500 psi (24 MPa, 241 bar)

10 ft (3 m) whip hose, 1/4 in. (6 mm) or 3/8 in. (10 mm) diameter, 2000 psi (14 MPa, 140 bar) or 3500 psi (24 MPa, 241 bar). See 309572.

Fusion Spray Gun

Air Purge Gun available in round or flat pattern. See 309550. Mechanical Purge Gun available in round or flat pattern. See manual 309856. Clear Shot Gun available in round or flat pattern. See manual 312666.

P2 Spray Gun

Probler P2 Gun available in round or flat pattern. See 313213.

Y-Strainer Screen

Replacement strainer screen for fluid Y-strainer; 20 mesh.

| Part | Description |
|--------|-------------------|
| 26A349 | 20 mesh (2 pack) |
| 26A350 | 20 mesh (10 pack) |
| 255082 | 80 mesh (2 pack) |
| 255083 | 80 mesh (10 pack) |

15D909 Air Filter Element

Replacement air filter element; 5 micron.

262695 Wheel Kit

All hardware and wheels to convert model 262572.

Recommended Spare Parts

Keep the following spare parts on hand to reduce downtime.

| Model | Part | Description |
|----------------|--------|---|
| A-25 | 262648 | Pump, Resin (B) side |
| | 246421 | Resin (B) Pump Repair Kit for 262648 pump |
| | 262647 | Pump, ISO (A) side |
| | 15C851 | ISO (A) Pump Repair Kit for 262647 pump |
| | 246963 | Wet Cup Kit for 262647 pump |
| A-XP1 | 24Y174 | Pump, Resin (B) side |
| | 24Y175 | Pump, ISO (A) side |
| | 17K351 | ISO (A) Pump Repair Kit for 24Y175 |
| | 17K352 | Resin (B) Pump Repair Kit for 24Y174 |
| A-25 and A-XP1 | 206995 | TSL bottle, 1 qt (1 liter) |
| | 101078 | Y-Strainer; includes 26A349 element |
| | 26A349 | Element, Y-Strainer, 20 mesh |
| | 15D909 | Element, air filter, 5 micron |
| | 239914 | Valve, recirc/spray; includes seat and gasket |

Parts

262572, Bare Reactor A-25 / 24Y164, A-XP1 Bare

262614, Reactor A-25 with DataTrak and Wheels / 24Y165, A-XP1 with DataTrak and Wheels

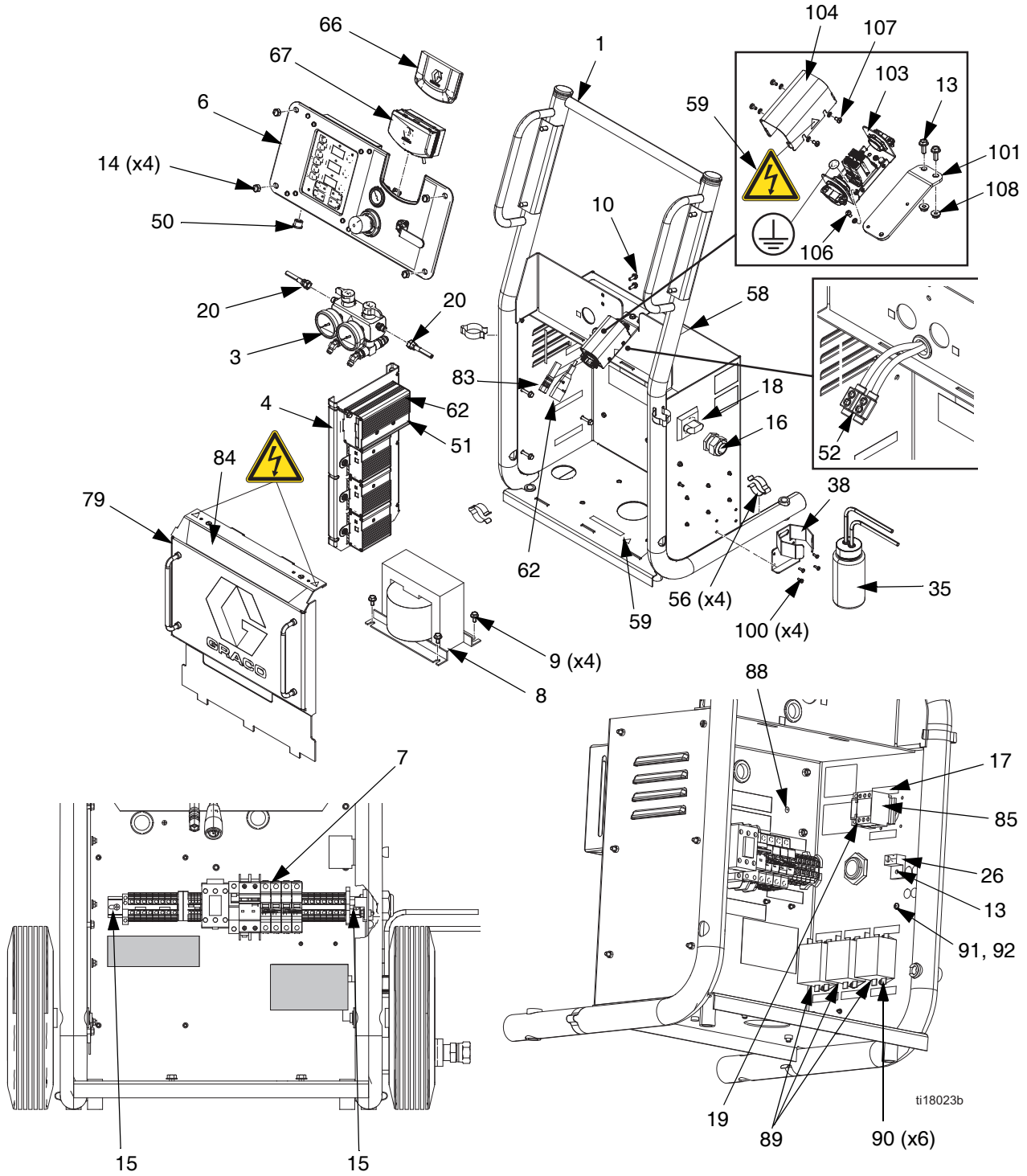

Parts

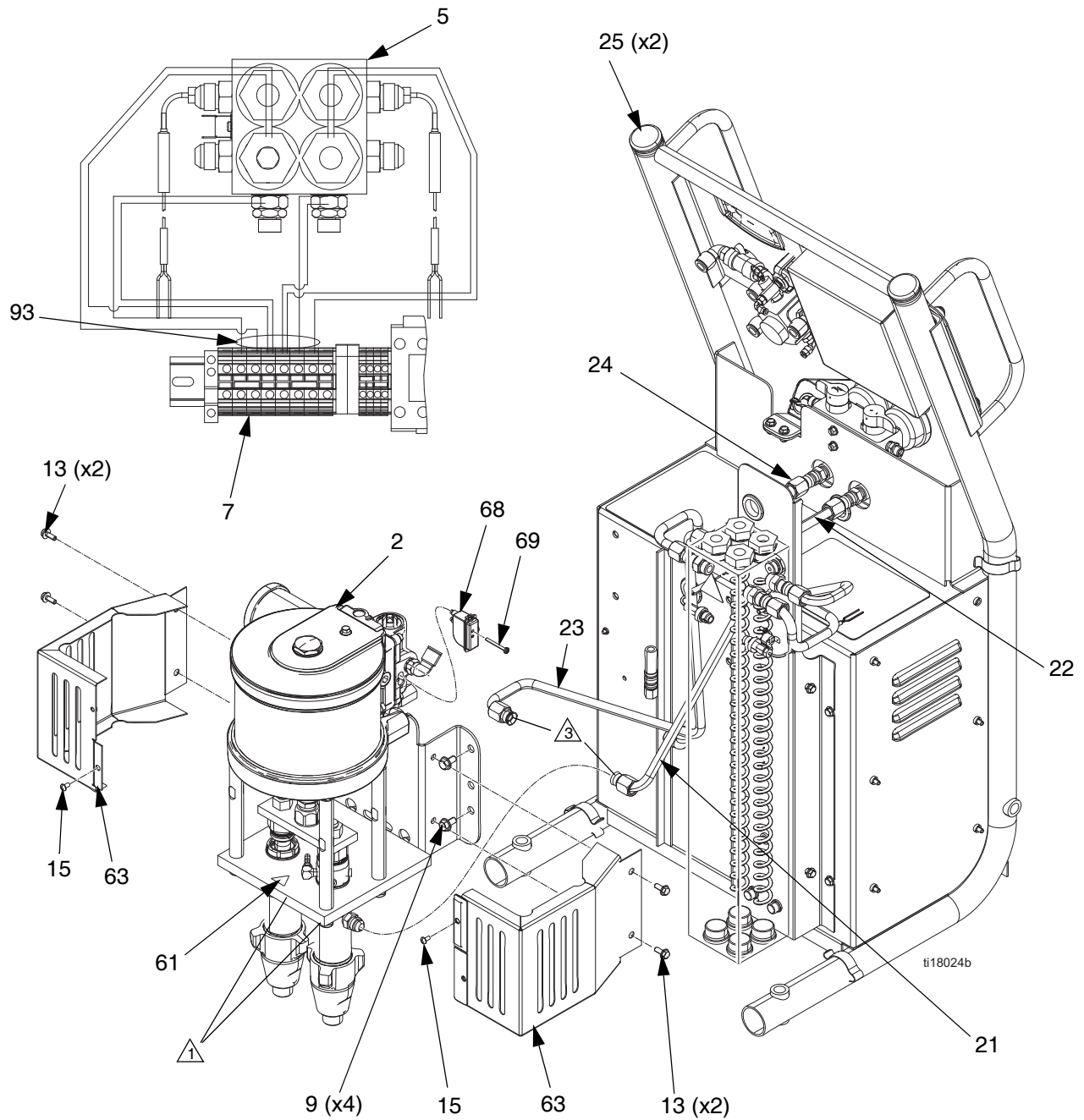

ti18024a

- ⚠ 1 Torque pump locking nuts to 66-74 ft-lbs (90-100 N•m).
- ⚠ 2 Apply anaerobic polyacrylate pipe sealant to all non-swiveling pipe threads.
- ⚠ 3 Torque tube ends to 212-265 in-lbs (24-30 N•m).
- ⚠ 4 Connect ground wire (94) from motor lug to ground lug in cabinet.
- ⚠ 5 For Series A only

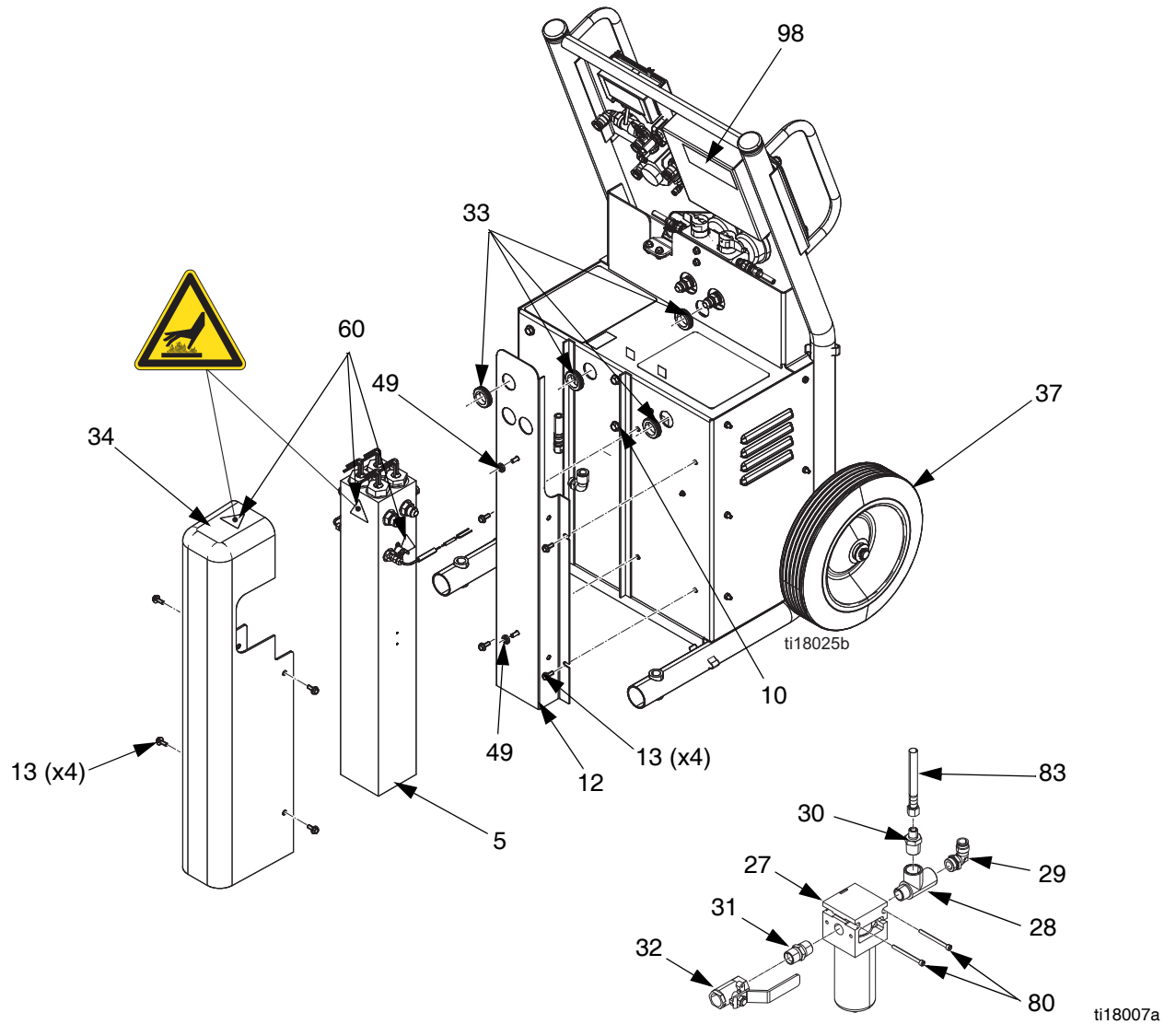

262572, Bare Reactor A-25 / 24Y164, Bare Reactor A-XP1
262614, Reactor A-25 with DataTrak and Wheels / 24Y165, Reactor A-XP1 with DataTrak and Wheels

| Ref. | Part | Description | Qty. | | | | |
|------|--------|--|------|----|--------|---|---|
| 1 | --- | CART | 1 | 6 | 262575 | PANEL (A-25), control; see page 45 | 1 |
| 2 | 262573 | PUMP (A-25); see page 49 | 1 | | 24Y167 | PANEL (A-XP1), control; see page 45 | |
| | 24Y086 | PUMP (A-XP1); see page 49 | | 7 | 262576 | MODULE (A-25), breaker; see page | 1 |
| 3 | 262577 | MANIFOLD (A-25), relief; see page 47 | 1 | | 24Y166 | MODULE (A-XP1), breaker; see page 51 | |
| | 24Y177 | MANIFOLD (A-XP1), relief; see page 47 | | 8 | 247840 | TRANSFORMER, 2790va, 230/62 | 1 |
| 4 | --- | PANEL, control, heater; see page 46 | 1 | 9 | 111799 | SCREW, cap, hex hd; M8 x 1.25 | 8 |
| 5 | 24J788 | HEATER (A-25), system, (6.0kw, 230v); see page 48 | 1 | 10 | 108296 | SCREW, mach, hex wash hd; 1/4-20 UNC-2A | 4 |
| | 24Y163 | HEATER (A-XP1), system, (6.0kw, 230v); see page 48 | | 11 | 125621 | SCREW, machine, hex washer, hd; M6 x 1 | 6 |
| | | | | 12 | 16G917 | BRACKET, heater | 1 |

Parts

| | | | | | | | |
|------|--------|-------------------------------------|----|------|--------|--|----|
| 13 | 114182 | SCREW, mach, hex flange; M6 x 1 | 15 | 65 | --- | TUBE, polyurethane, rnd, black; 5.12 | 1 |
| 14 | 117623 | NUT, cap, 3/8-16 | 4 | | | ft (1.56 m); see page 50 | |
| 15 | 106084 | SCREW, mach, pan hd; M5 x 0.8 | 2 | 66★ | --- | INSERT, control panel | 2 |
| 16 | 117682 | BUSHING, strain relief | 1 | 67† | 24B563 | KIT, DataTrak | 1 |
| 17 | 123970 | SWITCH (A-25), disconnect, 40a | 1 | 68†✱ | 24B659 | SWITCH, reed assy | 1 |
| | 123969 | SWITCH (A-XP1), disconnect, 40a | 1 | 69†✱ | --- | FASTENER, screw, pan head, m4 x | 1 |
| | | | | | | 35mm | |
| 18 | 123971 | KNOB (A-25), disconnect, operator | 1 | 79 | 262581 | COVER, electrical, assembly | 1 |
| | 123967 | KNOB (A-XP1), disconnect, operator | 1 | 80 | --- | SCREW, shcs, m5x60 | 2 |
| 19 | 123972 | SWITCH (A-25), fourth pole | 1 | 82‡ | 15H187 | WIRE, jumper, w/quick disconnect | 1 |
| | 123968 | SWITCH (A-XP1), fourth pole | 1 | 83 | 16P244 | HOSE, coupled, 2.63 ft. (0.8 m) | 1 |
| 20 | 17H018 | COUPLING, hose | 2 | 84 | --- | LABEL, product | 1 |
| 21 | 16G921 | TUBE, fluid, A, heater, inlet | 1 | 85▲ | 16J808 | LABEL, warning, disconnect wiring | 1 |
| 22 | 16G922 | TUBE, fluid, A, heater, outlet | 1 | 88 | 195874 | SCREW, phillips, pan hd; M4 x 8 | 1 |
| 23 | 16G923 | TUBE, fluid, B, heater, inlet | 1 | 89 | 16K669 | FILTER, electrical | 3 |
| 24 | 16G924 | TUBE, fluid, B, heater, outlet | 1 | 90 | 115266 | SCREW, cap, socket hd; M5 x 10 | 6 |
| 25 | 112125 | PLUG, tube | 2 | 91 | --- | SCREW, pan hd; M5 x 16 | 1 |
| 26 | 117666 | TERMINAL, ground | 1 | 92 | --- | WASHER, #10, external tooth lock | 1 |
| 27 | 15D795 | FILTER, air, 40 micron | 1 | 93 | --- | TUBE, pe, spiral, wrapping; 1.2 ft (0.4 | 1 |
| 28 | 107128 | TEE, service | 1 | | | m) | |
| 29 | 16X096 | ELBOW, male, swivel | 1 | 94 | 16M086 | WIRE, ground, pump | 1 |
| 30 | 162449 | NIPPLE, reducing | 1 | 95‡ | 114601 | CONDUIT, flexible, non-metallic | 1 |
| 31 | 158491 | NIPPLE | 1 | 96‡ | --- | SLEEVE, heat-shrink, 2:1; 0.75 ft, 1/2 | 1 |
| 32 | 262660 | VALVE, ball, 1/2 npt x 1/2 npt | 1 | | | in. ID, 1/4 in. OD | |
| 33 | 114269 | GROMMET, rubber | 4 | 97‡ | 120573 | BRIDGE, plug-in, jumper | 4 |
| 34 | 16G918 | COVER, heater | 1 | 98 | 16M088 | LABEL, error codes | 1 |
| 35 | 246995 | BOTTLE, assembly, complete | 1 | 99‡ | 114958 | STAP, tie | 10 |
| 36 | 234366 | KIT, fluid inlet, pair; see page 47 | 1 | 100 | 105676 | SCREW, pan hd | 4 |
| 37† | 262695 | KIT, wheel; see page 45 | 2 | 101 | 17D892 | BRACKET, connector | 1 |
| 38 | 16M152 | BRACKET, lube, reservoir | 1 | 103 | 24W204 | ENCLOSURE, terminal block | 1 |
| 44‡ | 247791 | HARNESS, wire, hose | 1 | 104 | 25A234 | ENCLOSURE, cover | 1 |
| 45‡ | 261669 | KIT, fluid temp sensor, coupler | 1 | 106 | 16P338 | SCREW, serrated hex hd 10-32 x .25 | 2 |
| 49 | 167002 | INSULATOR, heat | 2 | 107 | 16X129 | SCREW, Phillips, tooth, 8-32 x .375 | 5 |
| 50 | 16J433 | HARNESS, wire, display, ext. | 1 | 108 | 15U698 | NUT, M6, serrated flange | 2 |
| 51 | 16J434 | HARNESS, over temp, a-side, b-side | 1 | | | | |
| 52* | 261821 | CONNECTOR, wire, 6awg | 1 | | | ▲ Replacement Danger and Warning labels, tags, and cards | |
| 53†* | --- | FLUID, oxide inhibitor | 1 | | | are available at no cost. | |
| 54‡ | 206994 | FLUID, TSL, 8 oz. bottle | 1 | | | † Only used with 262614. | |
| 55‡ | 206995 | FLUID, TSL, 1 qt. | 1 | | | ★ Only used with 262572. | |
| 56 | 186494 | CLIP, spring | 4 | | | ✱ Included in Reed Switch Kit 24B659. | |
| 58▲ | 15G280 | LABEL, warning | 1 | | | ‡ Not shown. | |
| 59▲ | 189930 | LABEL, caution | 2 | | | * For series A only. | |
| 60▲ | 189285 | LABEL, caution | 3 | | | | |
| 61▲ | 15H108 | LABEL, pinch point | 1 | | | | |
| 62 | 15B380 | CABLE, hose, control | 1 | | | | |
| 63 | 16G952 | COVER, pump | 2 | | | | |
| 64 | --- | TUBE, polyethylene, rnd; 3/4 OD; | 1 | | | | |
| | | 0.75 ft (0.2 m); see page 50 | | | | | |

Control Panel, A-25: 262575, A-XP1: 24Y176

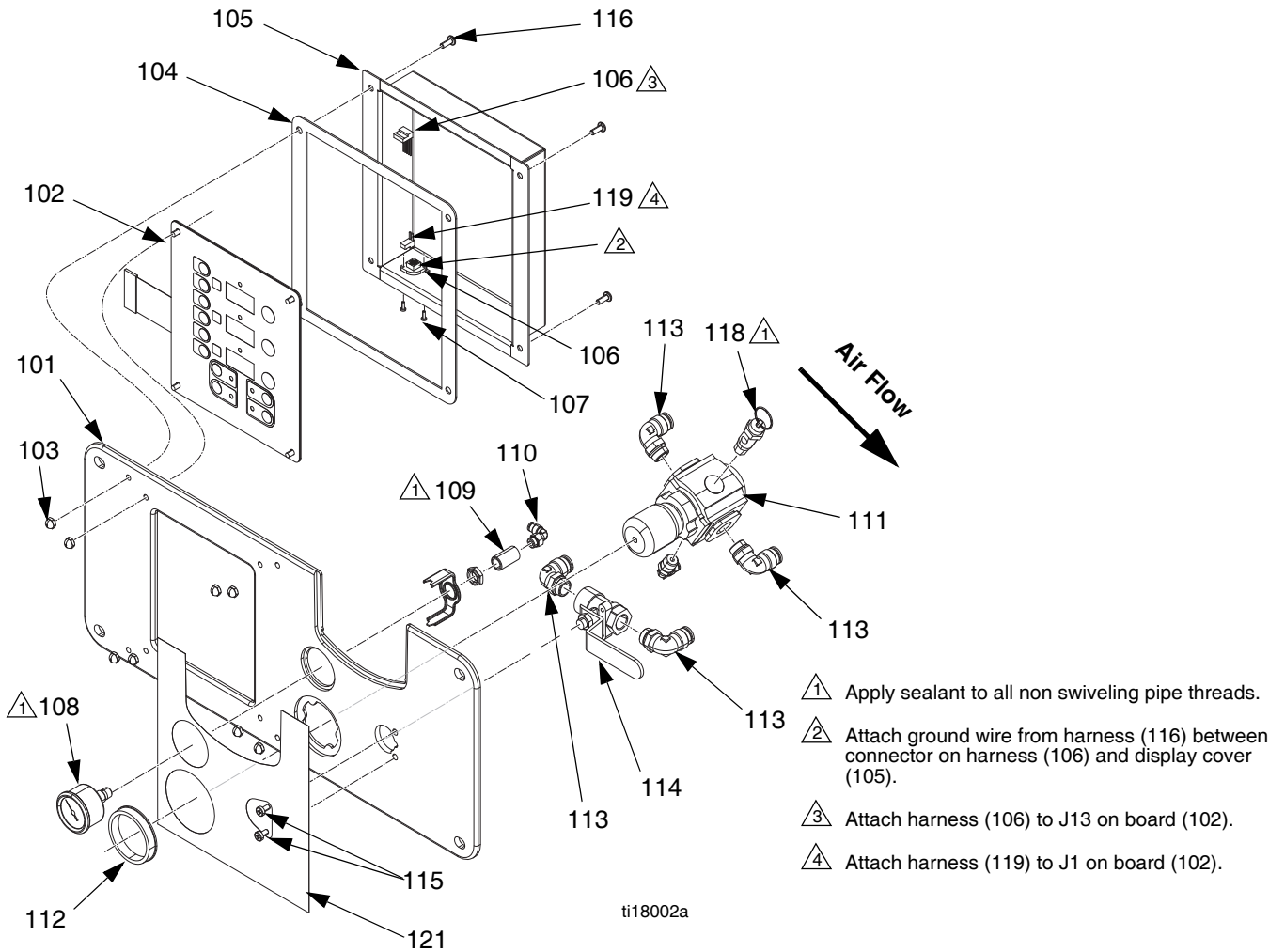

| Ref. | Part | Description | Qty. |
|------|--------|---|------|
| 101 | 16G912 | PLATE, display | 1 |
| 102 | 24G883 | DISPLAY, temperature; includes 102a-102c | 1 |
| 102a | 24G882 | BOARD, circuit | 1 |
| 102b | 246479 | SWITCH, membrane | 1 |
| 102c | 112324 | SCREW | 4 |
| 103 | 117523 | NUT, cap (#10) | 8 |
| 104 | 16G958 | GASKET, display cover | 1 |
| 105 | 16G913 | COVER, display | 1 |
| 106 | 16J432 | HARNESS, wire, display | 1 |
| 107 | --- | SCREW, pan head, phillips | 2 |
| 108 | 116257 | GAUGE, pressure | 1 |
| 109 | 100451 | COUPLING, 1/8 npt | 1 |
| 110 | 114151 | FITTING, elbow, male, swivel | 1 |
| 111 | 15T536 | REGULATOR, air, 3/8 npt | 1 |
| 112 | 16F810 | NUT, regulator, steel | 1 |
| 113 | 16X066 | FITTING, elbow, male, swivel | 4 |
| 114 | 114362 | VALVE, ball, air | 1 |
| 115 | 110637 | SCREW, mach, pan head | 2 |
| 116 | 331342 | SCREW, screw 10-24 x1/2 in. ph 4 pn hd | 1 |
| 117 | 114469 | FITTING, elbow, m swivel | 1 |
| 118 | 116643 | VALVE (A-25), relief, air, 90 psi (620.5 kPa) | 1 |
| | 113498 | VALVE (A-XP1), relief, air, 100 psi (620.5 kPa) | 1 |
| 119 | 16J431 | HARNESS, jumper, heater display | 1 |
| 121 | 16K525 | LABEL, control | 1 |

Temperature Control

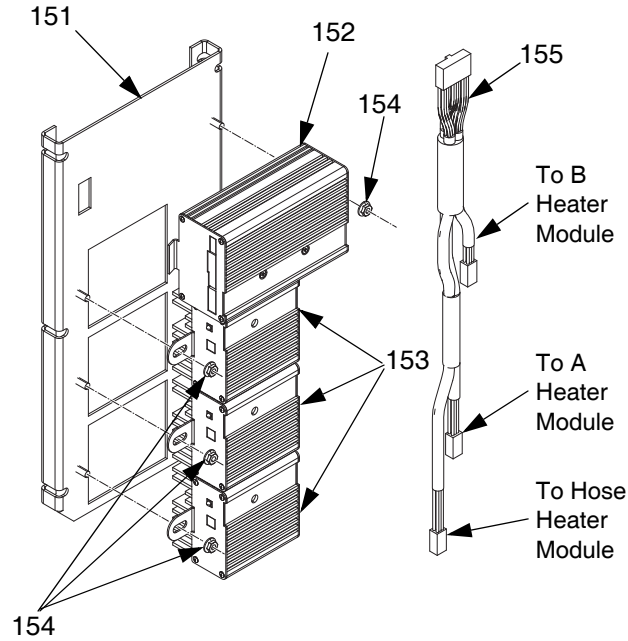

| Ref. | Part | Description | Qty. |
|------|--------|-----------------------------|------|
| 151 | 16G925 | PANEL, pod, mounting | 1 |
| 152 | 247827 | MODULE, heater control | 1 |
| 153 | 247828 | MODULE, heater | 3 |
| 154 | 114183 | NUT, hex, flanged, serrated | 4 |
| 155 | 247801 | CABLE, communication | 1 |

Wheel Kit, 262695

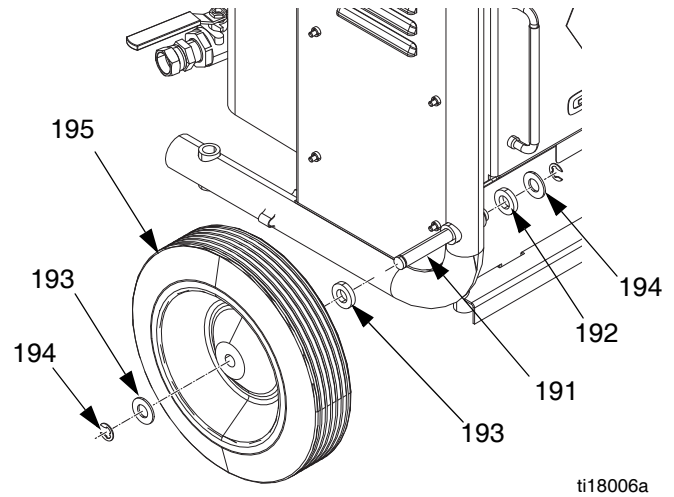

| Ref. | Part | Description | Qty. |
|-------|--------|-------------------------------|------|
| 191 † | 16H182 | AXLE, wheel | 2 |
| 192 † | 111841 | WASHER, plain 5/8 | 4 |
| 193 † | 191824 | WASHER, space | 4 |
| 194 † | 101242 | RING, retaining, ext. | 4 |
| 195 † | 16G920 | WHEEL, semi pneumatic, offset | 2 |

† Only used with 262614. Available as add on wheel kit 262695.

Fluid Manifold

A-25: 262577
A-XP1: 24Y177

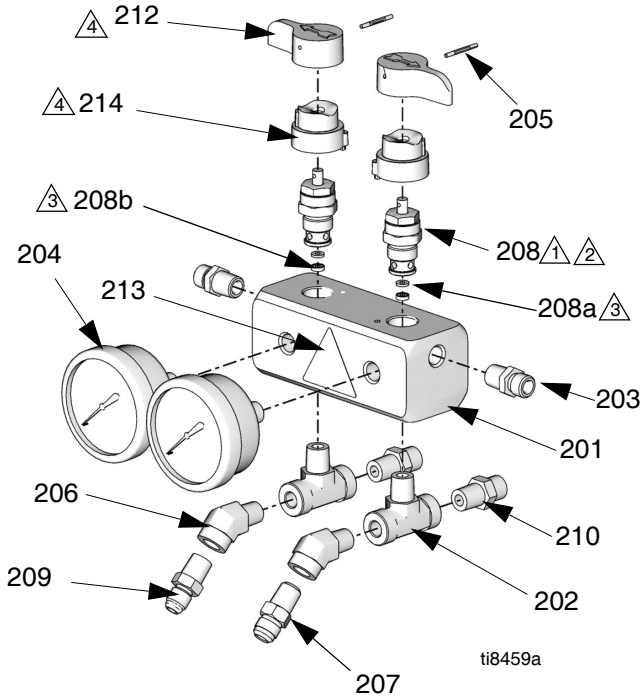

- ▲1 Apply sealant and torque to 250 in-lbs (28 N•m).
- ▲2 Use blue thread lock on valve cartridge threads into manifold.
- ▲3 Part of item 208.
- ▲4 Apply lubricant to mating surfaces.
- ▲5 Apply pipe sealant to all NPT threads.

| Ref. | Part | Description | Qty. |
|------|--------|-------------------------------------|------|
| 201 | 24K993 | MANIFOLD, recirculation | 1 |
| 202 | 108638 | FITTING, pipe, tee | 2 |
| 203 | 162453 | FITTING, (1/4 npsm x 1/4 npt) | 2 |
| 204 | 113641 | GAUGE (A-25), pressure, fluid, SST | 2 |
| | 115523 | GAUGE (A-XP1), pressure, fluid, SST | 2 |
| 205 | 111600 | PIN, grooved | 2 |
| 206 | 119789 | FITTING, elbow, street, 45 deg, | 2 |
| 207 | 116704 | ADAPTER, 3/8 JIC x 1/4 npt | 1 |
| 208 | 239914 | VALVE, drain; includes 208a, 208b | 2 |
| 208a | --- | SEAT | 2 |
| 208b | --- | GASKET | 2 |
| 209 | 119998 | ADAPTER, 5/16 JIC x 1/4 npt | 1 |
| 210 | 116702 | FITTING, union, 1/4 npt x 3/8 JIC | 2 |
| 212 | 187625 | HANDLE, valve, drain | 2 |
| 213▲ | 189285 | LABEL, caution | 1 |
| 214 | 224807 | BASE, valve | 2 |

▲ Replacement Danger and Warning labels, tags, and cards are available at no cost.

Fluid Inlet Kit, 234366

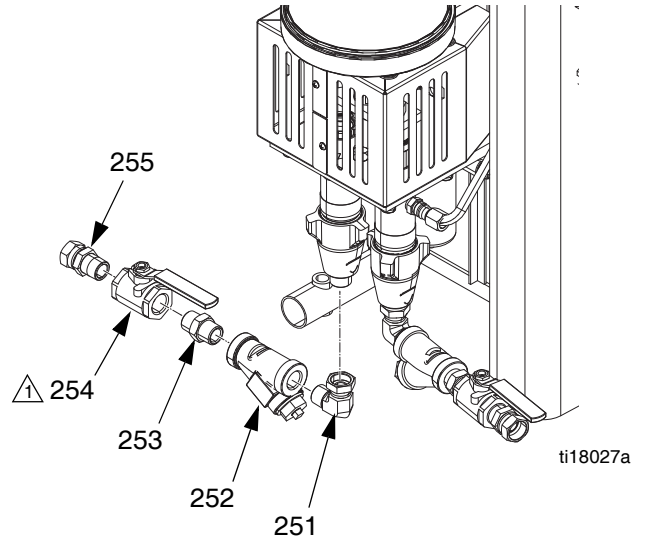

- ▲1 Assemble ball valves in orientation shown.
- ▲2 Apply anaerobic polyacrylate pipe sealant to all NPT connections.

| Ref. | Part | Description | Qty. |
|------|--------|---|------|
| 251 | 160327 | UNION, adapter, 90°; 3/4 npt(m) x 3/4-14 npt(f) | 2 |
| 252 | 101078 | Y-STRAINER; 20 m screen | 2 |
| 253 | C20487 | NIPPLE, 3/4 npt | 2 |
| 254 | 109077 | VALVE, ball; 3/4 npt (fbe) | 2 |
| 255 | 118459 | UNION, swivel; 3/4-14 npt(m)x 3/4-14 npt(f) | 2 |
| 256 | 26A349 | ELEMENT, 20 mesh | 2 |

A-XP1: 10 kw Dual Zone Heater, 24Y163
A-25: 6 kw Dual Zone Heater, 24J788

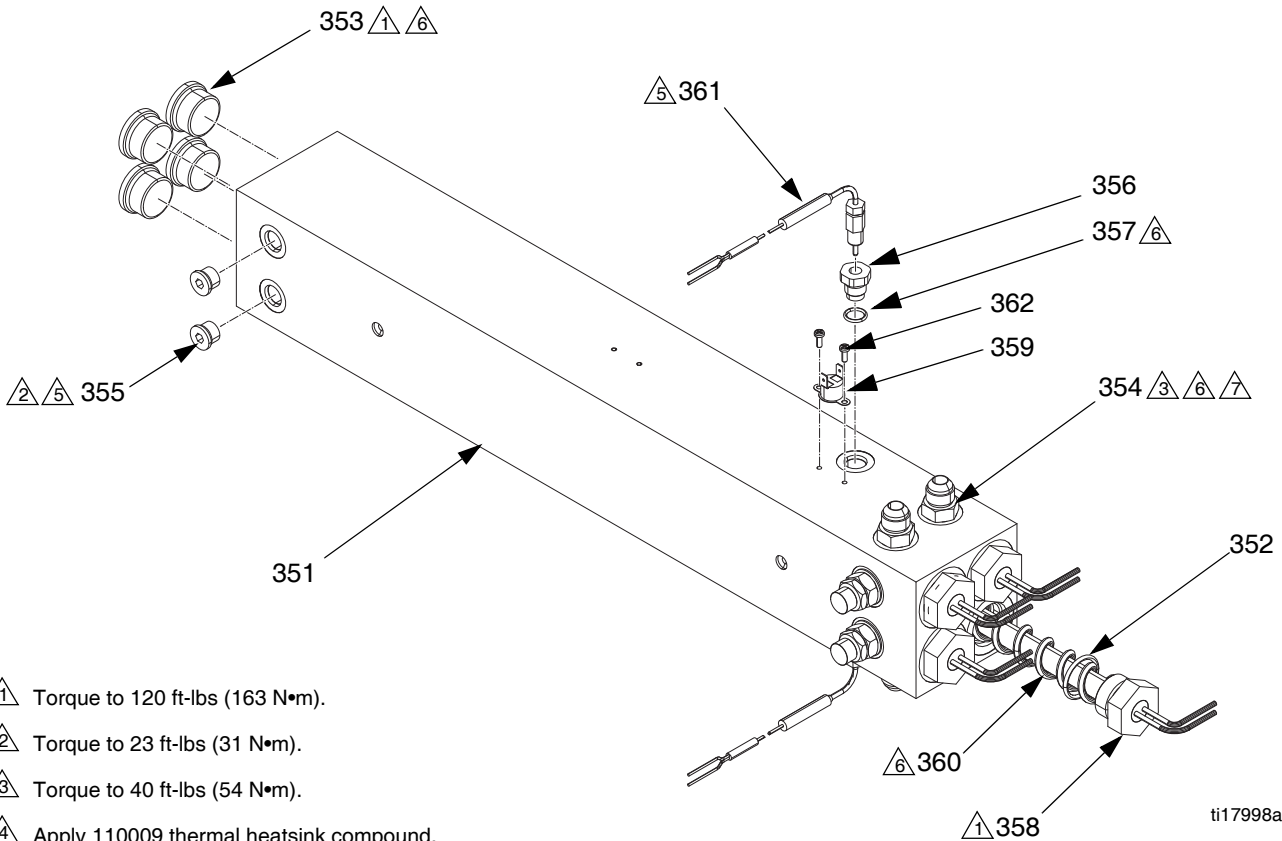

ti17998a

- ① Torque to 120 ft-lbs (163 N•m).
- ② Torque to 23 ft-lbs (31 N•m).
- ③ Torque to 40 ft-lbs (54 N•m).
- ④ Apply 110009 thermal heatsink compound.
- ⑤ Apply sealant and PTFE tape to all non swiveling and threads without o-rings.
- ⑥ Apply lubricant to o-rings.
- ⑦ Orient rupture disc housing (369) with exhaust hole pointing towards the bottom of the heater.

| Ref. | Part | Description | Qty. |
|------|--------|---|------|
| 351 | --- | HEATER, dual zone | 1 |
| 352 | 124132 | O-RING | 4 |
| 353 | 15H305 | FITTING, plug hollow hex 1-3/16 sae | 4 |
| 354 | 121309 | FITTING, adapter, sae-orb x jic | 4 |
| 355 | 15H304 | FITTING, plug 9/16 sae | 2 |
| 356 | 15H306 | ADAPTER, thermocouple, 9/16 x 1/8 | 2 |
| 357 | 120336 | O-RING, packing | 2 |
| 358 | 16A112 | HEATER (A-25), immersion, (1500w, 230v) | 4 |
| 359 | 15B137 | SWITCH, over temperature | 1 |
| 360 | 15B135 | MIXER, immersion heater | 4 |
| 361 | 117484 | SENSOR | 2 |
| 362 | --- | SCREW, mach, pnh | 2 |
| 369 | 247520 | KIT, rupture disc | 2 |

A-25 Air Motor Pump Assembly, 262573

A-XP1 Air Motor Pump Assembly, 24Y086

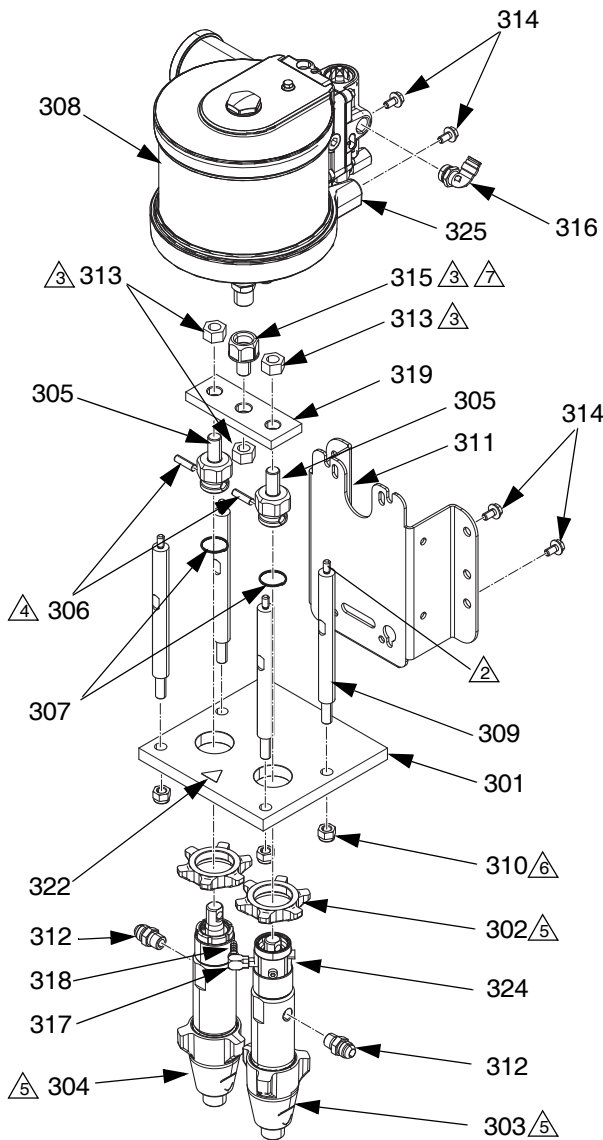

| Ref. | Part | Description | Qty. |
|------|--------|---|------|
| 301 | 16G915 | PLATE, Mounting, Cylinder | 1 |
| 302 | 193031 | NUT, retaining | 2 |
| 303 | 262647 | PUMP (A-25), displacement, w/lube; iso | 1 |
| | 24Y175 | PUMP (A-XP1), displacement, w/lube; iso | 1 |
| 304 | 262648 | PUMP (A-25), displacement; resin | 1 |
| | 24Y174 | PUMP (A-XP1), displacement; resin | 1 |
| 305 | 15J132 | LINK (A-25), connecting | 2 |
| | 17F967 | LINK (A-XP1), connecting | 2 |
| 306 | 183210 | PIN (A-25), str, hdls | 2 |
| | 176818 | PIN (A-XP1), str, hdls | 2 |
| 307 | 183169 | SPRING (A-25), retaining | 2 |
| | 176817 | SPRING (A-XP1), retaining | 2 |
| 308 | M12LP0 | MOTOR, air, NXT, 6 in., cycle only; see manual 312796 | 1 |
| 309 | 16G929 | ROD, tie | 4 |
| 310 | 125266 | NUT, lock, nylon, m12 | 4 |
| 311 | 16G926 | BRACKET, pump mounting | 1 |
| 312 | 117833 | ADAPTER (A-25), 3/4-16 JIC x 3/8 NPT | 2 |
| | 121310 | ADAPTER (A-XP1), 3/4-16 JIC x 3/8 NPT | 2 |
| 313 | 120553 | NUT, center lock, 5/8-18 | 3 |
| 314 | 111799 | SCREW, cap, hex hd | 4 |
| 315 | 16G914 | ADAPTER, rod | 1 |
| 316 | 16X096 | ELBOW, male, swivel | 1 |
| 317 | 15K783 | ELBOW, street, 90° | 1 |
| 318 | 116746 | FITTING, barbed, plated | 2 |
| 319 | 16G916 | PLATE, yoke, pump | 1 |
| 322 | 15H108 | LABEL, pinch point | 1 |
| 324 | 100139 | PLUG, PIPE | 2 |
| 325 | 15B565 | VALVE, 1/4 npt, park | 1 |

- 1 Apply PTFE tape and sealant to non-swiveling pipe threads.
- 2 Torque to 88.5-124 in.-lbs (10-14 N•m).
- 3 Torque to 77-85 ft-lbs (105-115 N•m). Torque nut (313) after assembly of item pin (306) and spring (307).
- 4 Install adapters so that pins (306) will be in-line with each other.
- 5 Lubricate threads of pump cylinders (303, 304) and plate (301) with lubricant prior to assembly into mounting plate. Assemble pump cylinder 1/2 thread above flush to one and one half thread above flush of mounting pate surface.
- 6 Torque to 27-32 ft-lbs (37-43 N•m).
- 7 Use blue thread lock (medium).

Air Tubing Connections

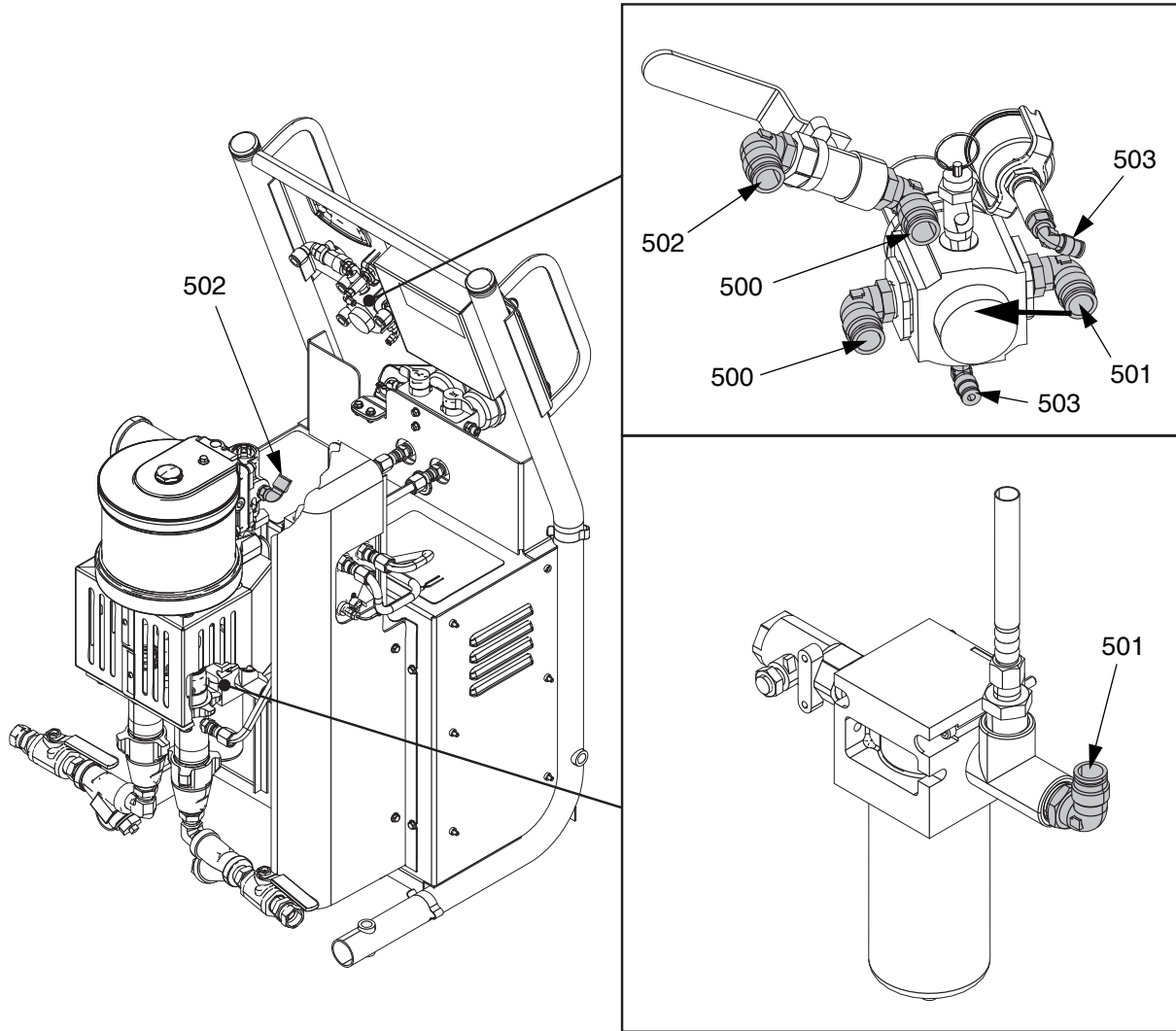

ii18009h

| Ref. | Length ft (m) | Connection | | Material | Color | Outside Diameter |
|------|------------------|------------|-----|----------|-------|-------------------|
| | | From | To | | | |
| 64 | 0.75 ft (0.23 m) | 503 | 503 | UHMWPE | Black | 5/32 in. (4 mm) |
| 65 | 2.66 ft (0.8 m) | 501 | 501 | Nylon | Black | 1/2 in. (12.7 mm) |
| 65 | 1.66 ft (0.5 m) | 502 | 502 | Nylon | Black | 1/2 in. (12.7 mm) |
| 65 | 0.75 ft (0.23 m) | 500 | 500 | Nylon | Black | 1/2 in. (12.7 mm) |

A-25 Breaker Module, 262576
A-XP1 Breaker Module, 24Y166

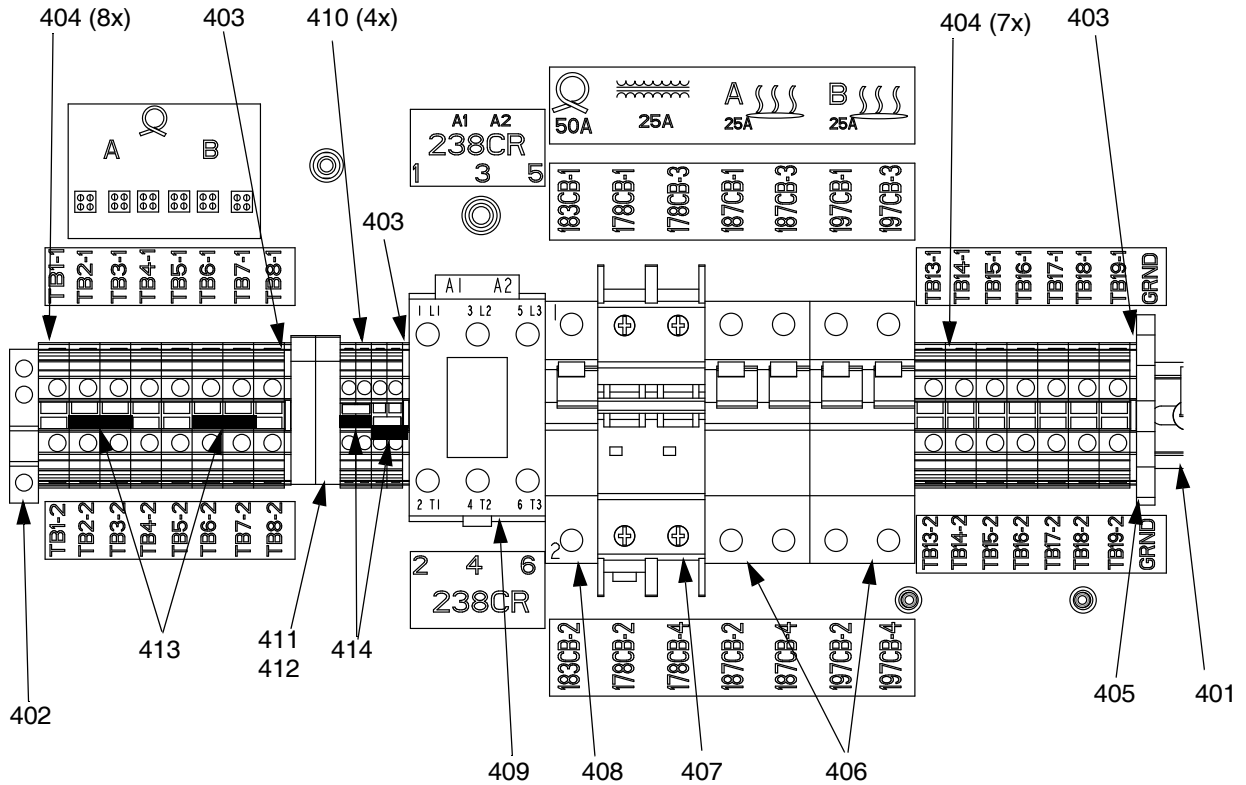

A-25:

| Ref. | Part | Description | Qty. |
|------|--------|---------------------------------------|------|
| 401 | 16H309 | RAIL, mounting | 1 |
| 402 | 112446 | BLOCK, clamp end | 1 |
| 403 | 120490 | COVER, end | 3 |
| 404 | 120570 | BLOCK, terminal | 15 |
| 405 | 255046 | BLOCK, terminal ground | 1 |
| 406 | 255050 | CIRCUIT BREAKER (A-25), 25a, 2p | 2 |
| 407 | 24M176 | CIRCUIT BREAKER (A-2), 30a, 2p | 1 |
| 408 | 255026 | CIRCUIT BREAKER, 1 pole, 50a, c curve | 1 |
| 409 | 255022 | RELAY, contactor, 65a, 3p | 1 |
| 410 | 120491 | BLOCK, terminal | 4 |
| 411 | 255043 | HOLDER, fuse term.block 5x20mm | 2 |
| 412 | 116225 | FUSE, 1a, 5x20mm | 2 |
| 413 | 120573 | BRIDGE, plug-in, (jumper) | 2 |
| 414 | 120485 | BRIDGE, plug-in, (jumper) | 2 |
| 415 | 16J534 | HARNESS (A-25), wiring | 1 |

A-XP1:

| Ref. | Part | Description | Qty. |
|------|--------|---------------------------------------|------|
| 401 | 16H309 | RAIL, mounting | 1 |
| 402 | 112446 | BLOCK, clamp end | 1 |
| 403 | 120490 | COVER, end | 3 |
| 404 | 120570 | BLOCK, terminal | 15 |
| 405 | 255046 | BLOCK, terminal ground | 1 |
| 407 | 123299 | CIRCUIT BREAKER (A-2), 30a, 2p | 3 |
| 408 | 255026 | CIRCUIT BREAKER, 1 pole, 50a, c curve | 1 |
| 409 | 255022 | RELAY, contactor, 65a, 3p | 1 |
| 410 | 120491 | BLOCK, terminal | 4 |
| 411 | 255043 | HOLDER, fuse term.block 5x20mm | 2 |
| 412 | 116225 | FUSE, 1a, 5x20mm | 2 |
| 413 | 120573 | BRIDGE, plug-in, (jumper) | 2 |
| 414 | 120485 | BRIDGE, plug-in, (jumper) | 2 |
| 415 | 17G102 | HARNESS (A-25), wiring | 1 |

Reactor A-25/A-XP1 Wiring Schematic

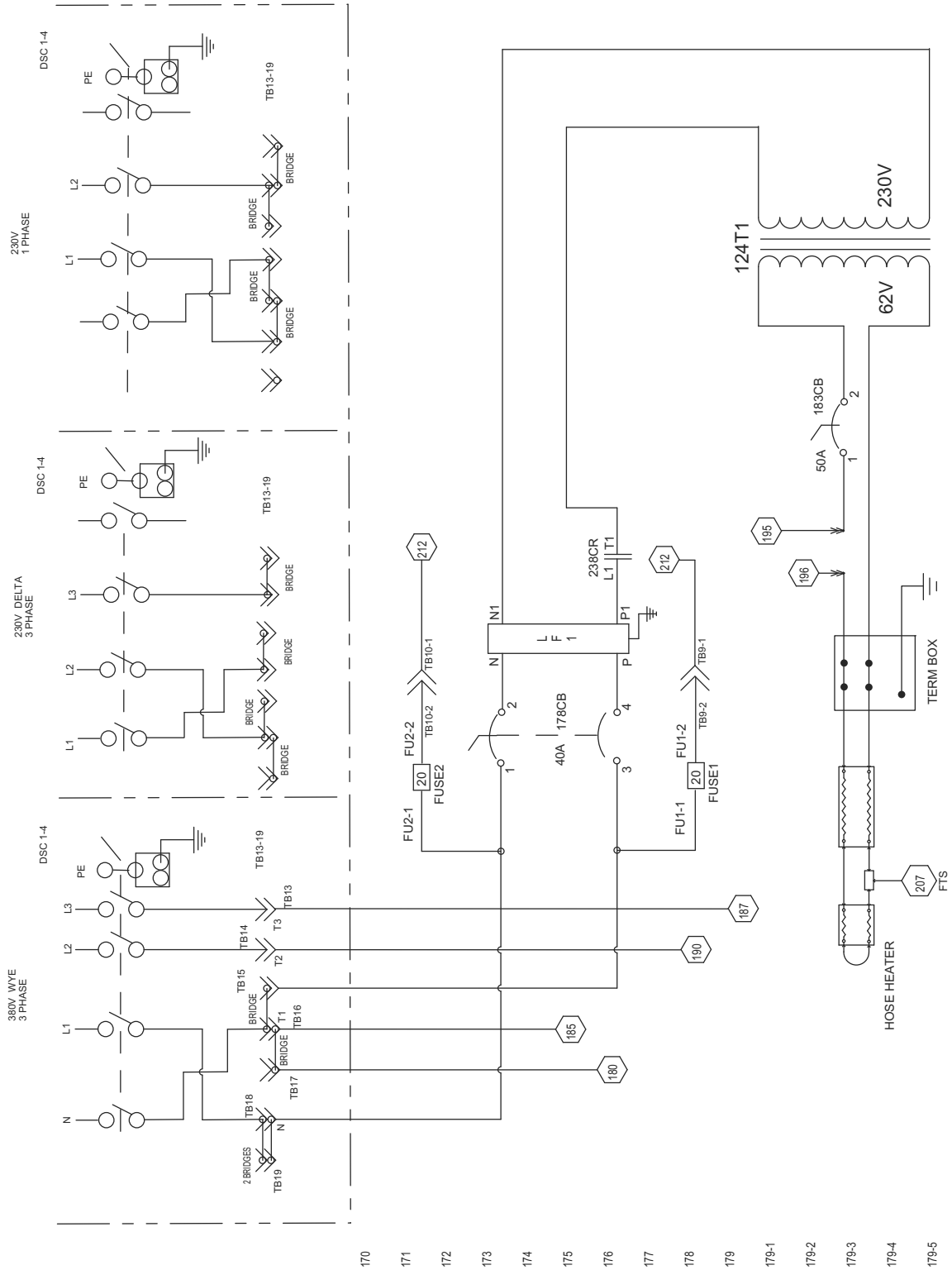

126925a

A-25

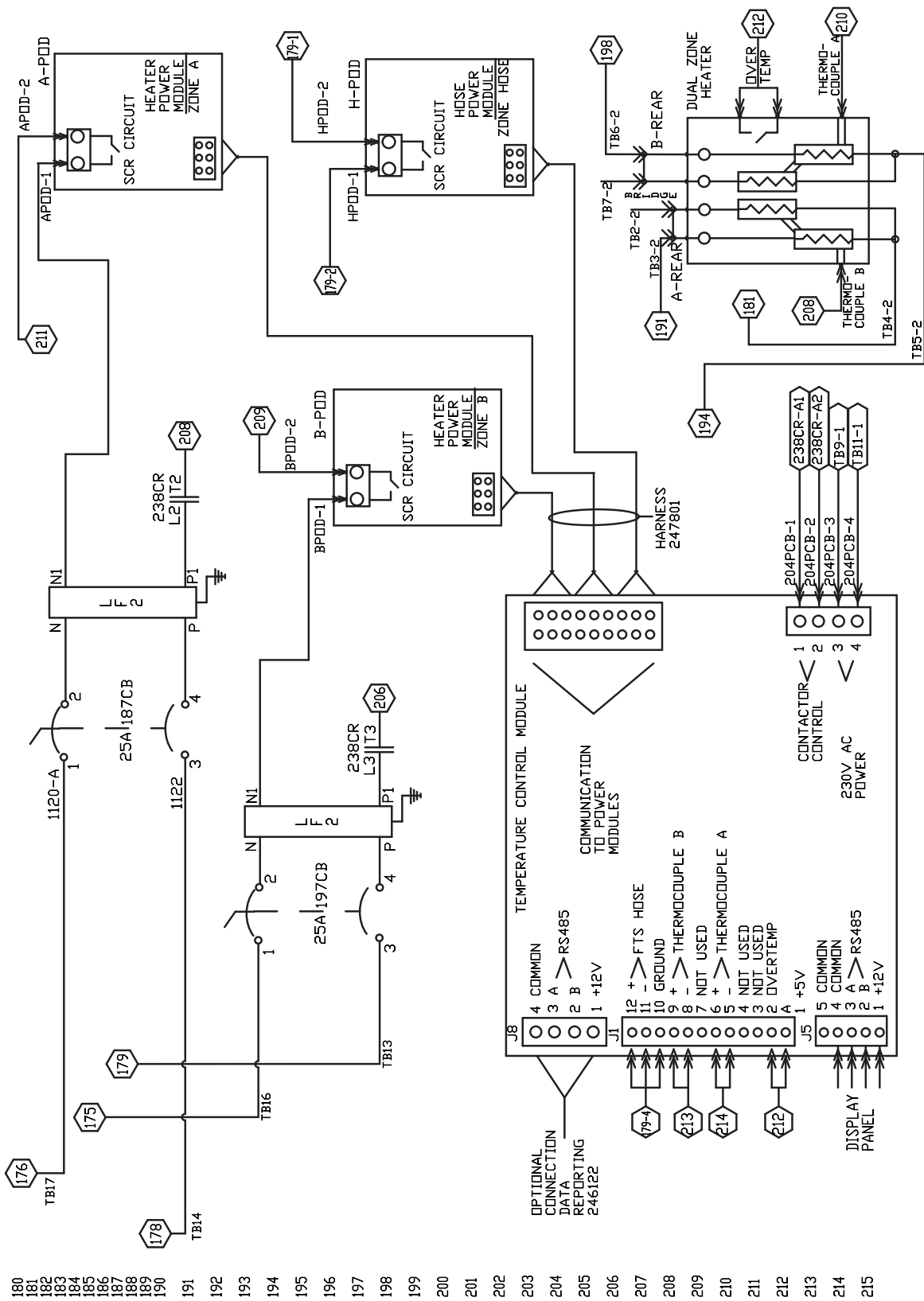

- 180
- 181
- 182
- 183
- 184
- 185
- 186
- 187
- 188
- 189
- 190
- 191
- 192
- 193
- 194
- 195
- 196
- 197
- 198
- 199
- 200
- 201
- 202
- 203
- 204
- 205
- 206
- 207
- 208
- 209
- 210
- 211
- 212
- 213
- 214
- 215

A-XP1

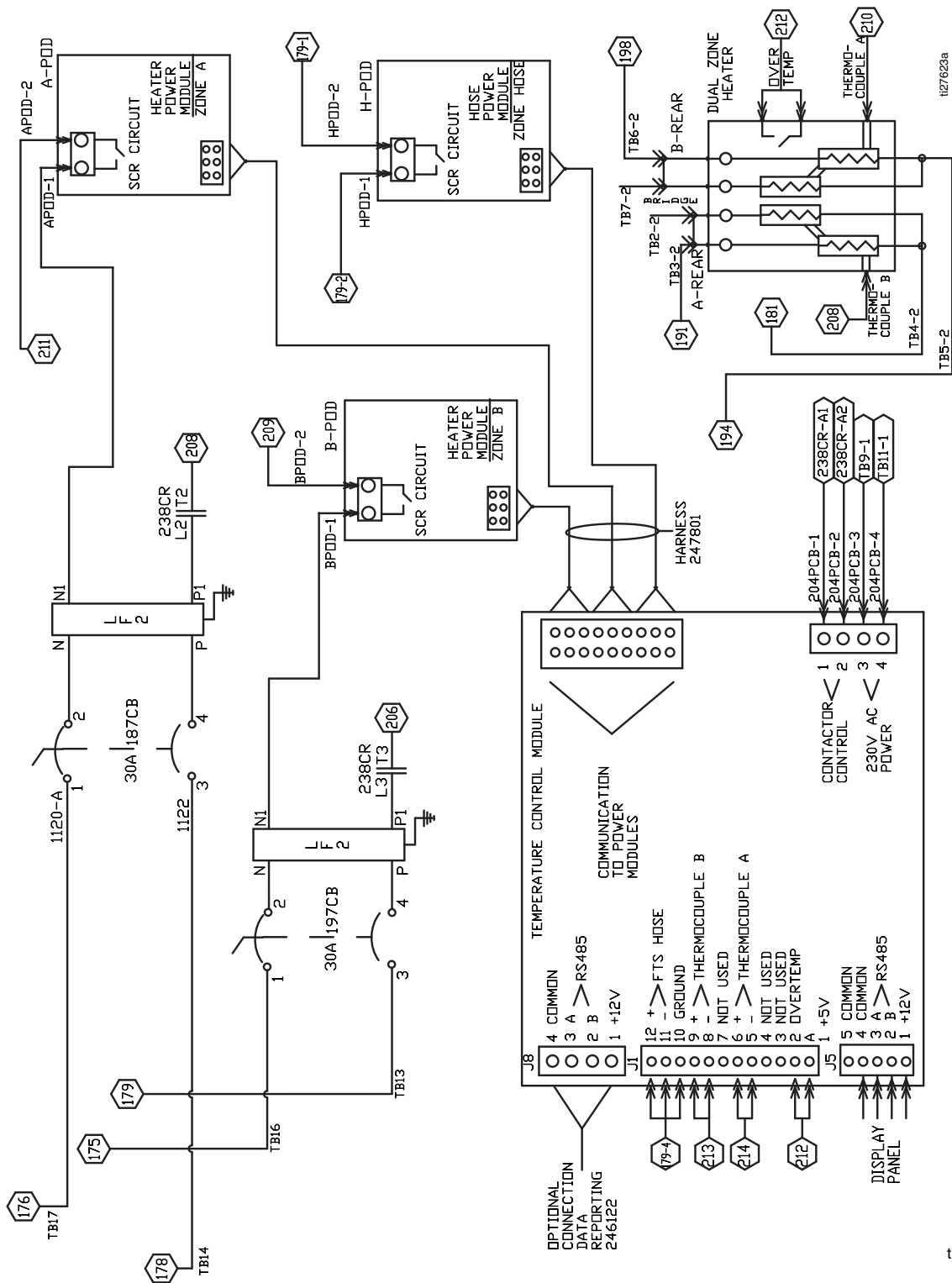

180
181
182
183
184
185
186
187
188
189
190
191
192
193
194
195
196
197
198
199
200
201
202
203
204
205
206
207
208
209
210
211
212
213
214
215

ti27623a

ti27623a

A-25

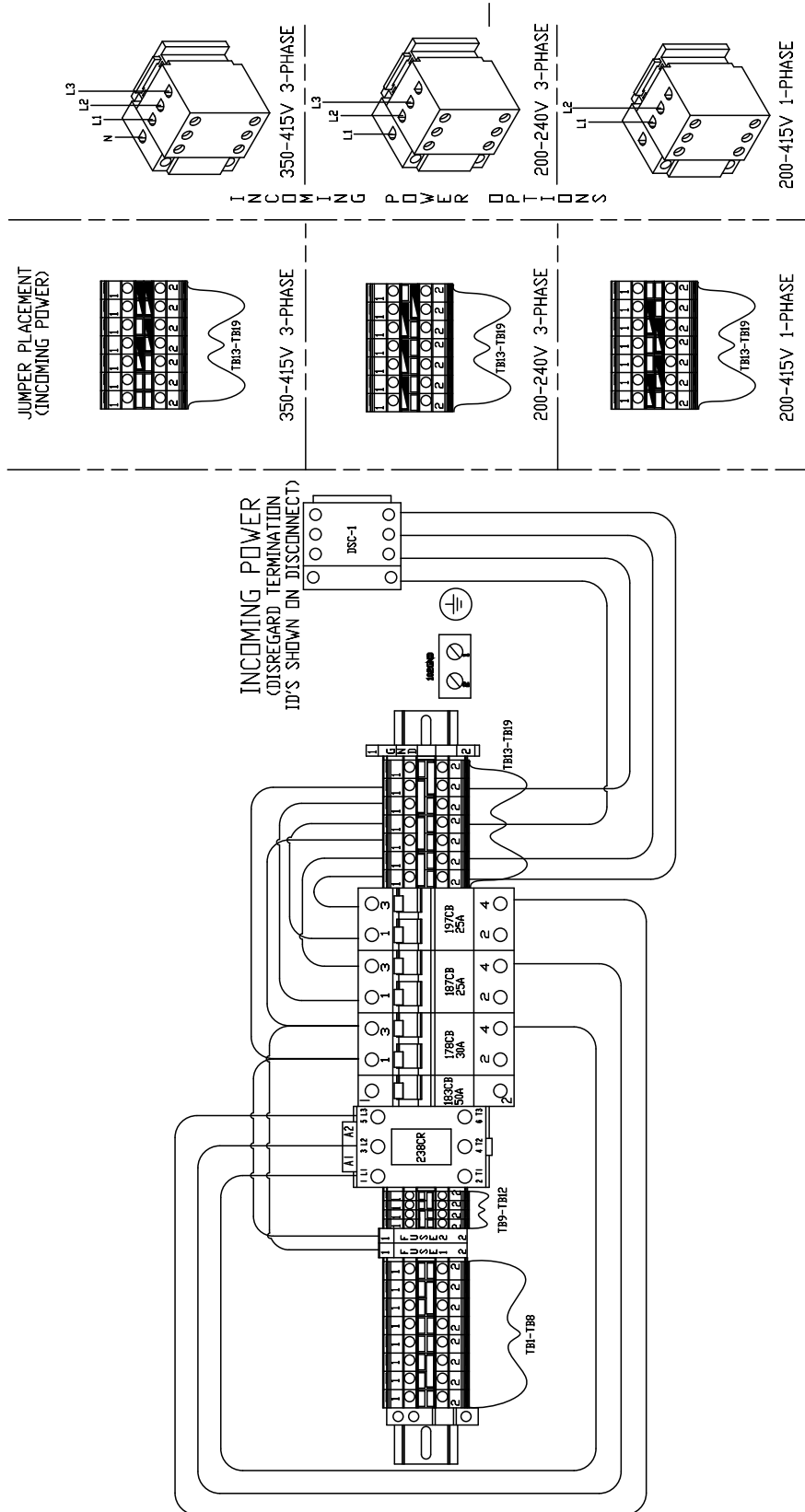

A-XP1

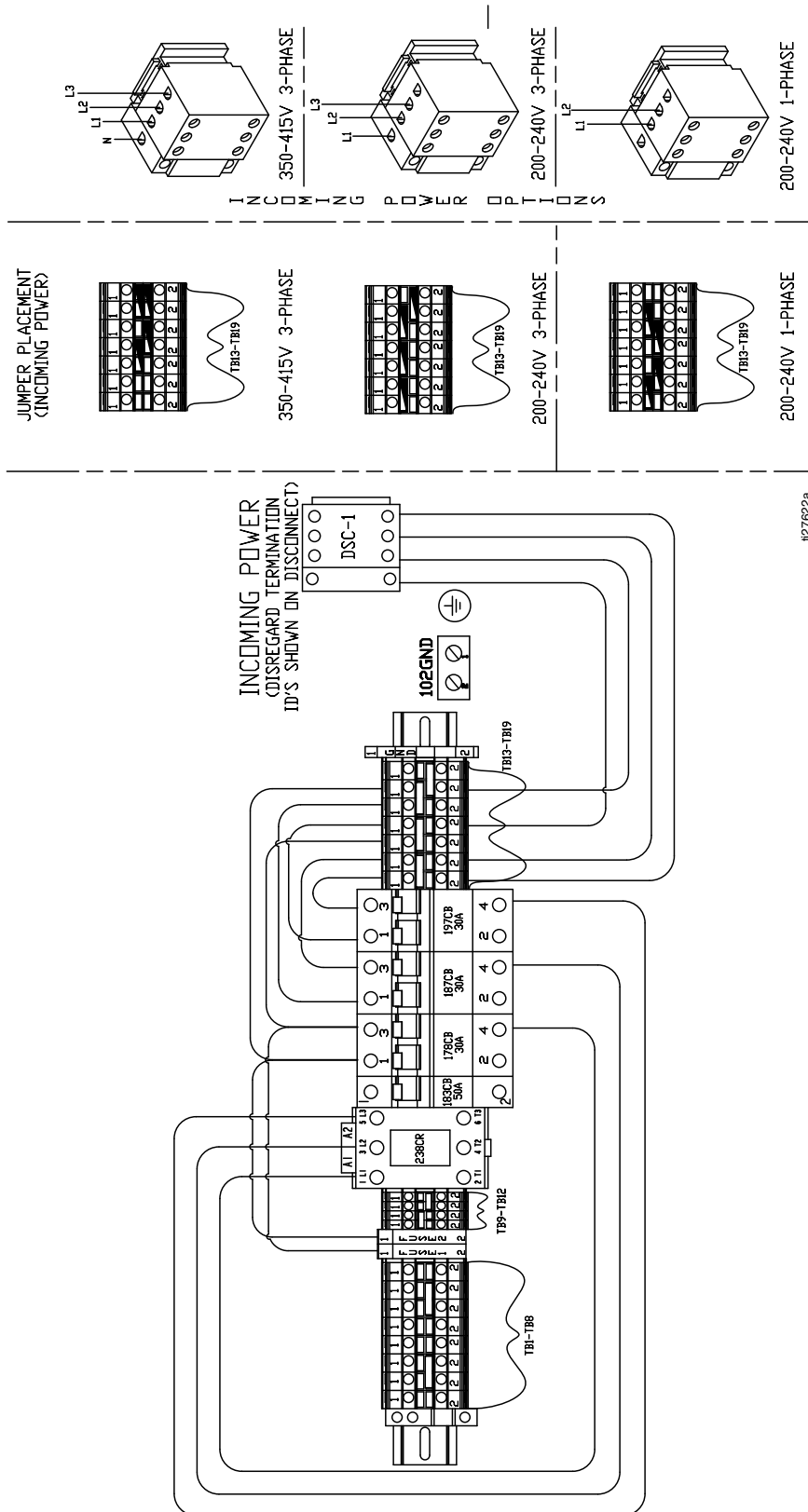

A-25

Simplified Schematic, Heater Controls

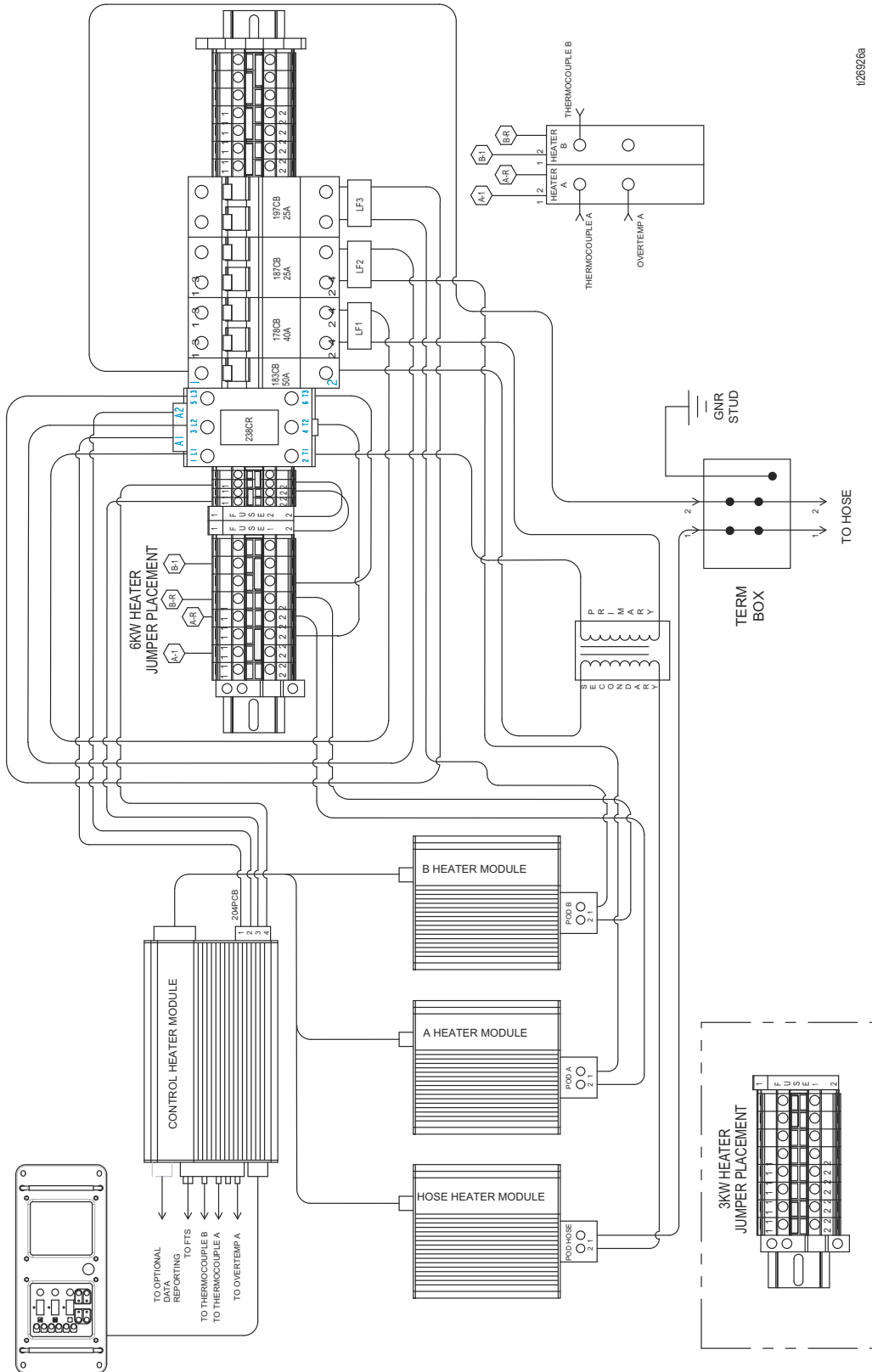

1226926a

A-XP1

Simplified Schematic, Heater Controls

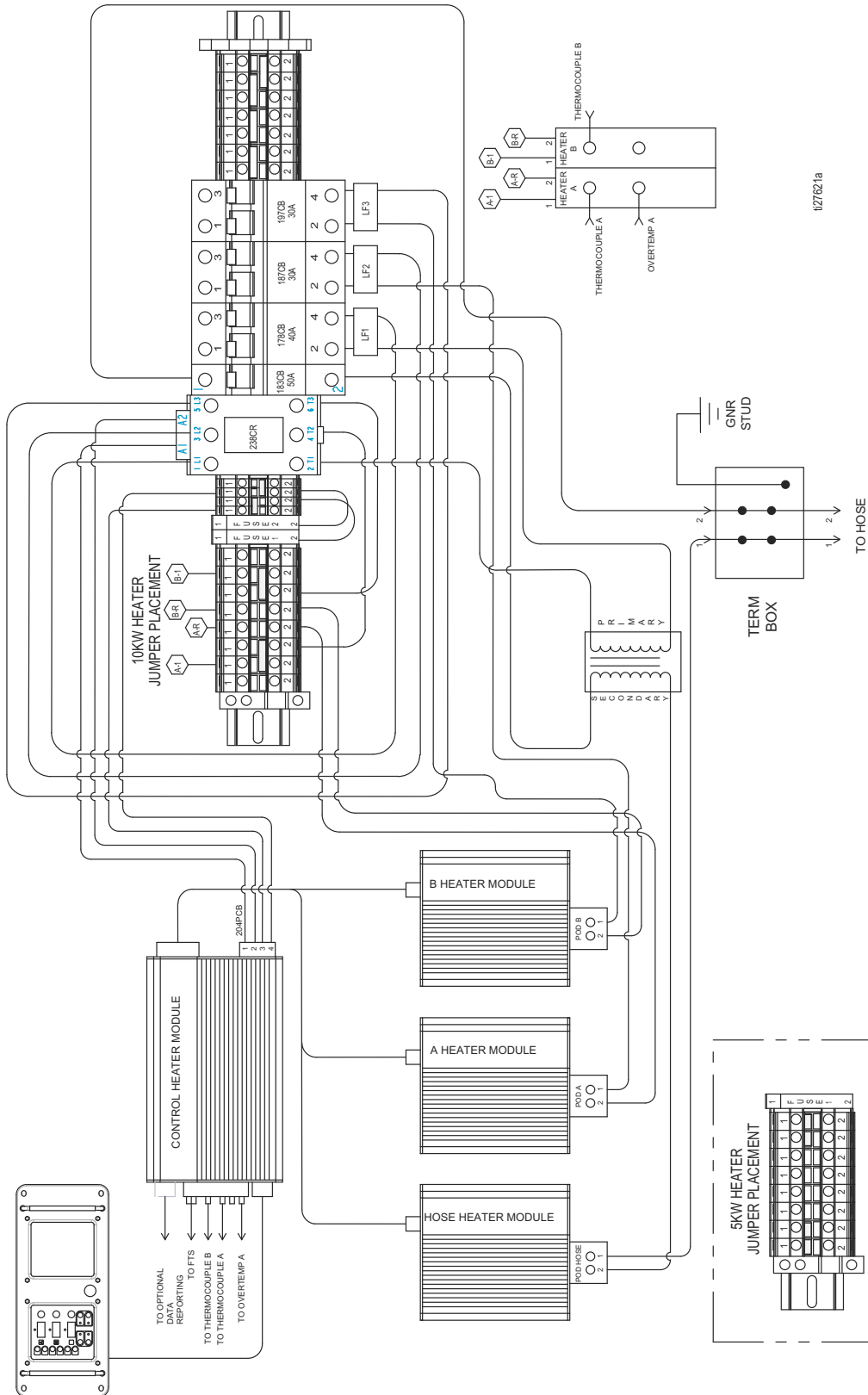

Technical Data

| Category | Data | |
|--|--|---|
| | A-25 | A-XP1 |
| Maximum Fluid Working Pressure | 2000 psi (14 MPa, 138 bar) | 3500 psi (24 MPa, 241 bar) |
| Maximum Air Supply Pressure | 125 psi (0.9 MPa, 9 bar) | 125 psi (0.9 MPa, 9 bar) |
| Maximum Air Working Pressure | 80 psi (550 kPa, 5.5 bar) | 100 psi (689 MPa, 6.9 bar) |
| Pressure Ratio | 25:1 | 35:1 |
| Air consumption | 28 scfm (0.8m ³ /min) 02 tip at 1500 psi install pressure | 32 scfm (0.9 m ³ /min) 00 tip at 2000 psi stall pressure |
| Machine Maximum Power with hose | 9000 Watts | 13,000 Watts |
| Voltage Tolerance (50/60 Hz): | | |
| 200-240VAC Nominal, 1 Phase | 195-253VAC | |
| 200-240VAC Nominal, 3 Phase (Delta) | 195-253VAC | |
| 350-415VAC Nominal, 3 Phase (WYE 200-240VAC Line to Neutral) | 338-457VAC | |
| Amperage Requirement (Full Load Peak)* | 40 amps @ 230 V, 1 Phase 32 amps @ 230 V, 3 Phase 18.5 amps @ 380 V, 3 Phase | 56 amps @ 230 V, 1 Phase 45amps @ 230 V, 3 Phase 26 amps @ 380 V, 3 Phase |
| Maximum Heater Fluid Temperature | 190 °F (88 °C) | |
| Maximum Hose Fluid Temperature | 180 °F (82 °C) | |
| Maximum Ambient Temperature | 120 °F (49 °C) | |
| Maximum Output | 25 lb/min. (11.4 kg/min.) | 1.5 gal/min at 2000 psi |
| Output Per Cycle (A and B) | 0.025 gal/cycle (0.095 ltr/cycle) | 0.017 gal/cycle (0.064 ltr/cycle) |
| Heater Power | 6000 Watts | 10,200 Watts |
| Hose Power | 2790 Watts | |
| Sound Pressure (see NXT air motor manual) | 70.2 dB(A) | |
| Sound Power (see NXT air motor manual) | 80.1 dB(A) | |
| Viscosity Range | 250-1500 centipoise (typical) | |
| Maximum Fluid Inlet Pressure | 300 psi (2.1 MPa, 21 bar) or 15% of output pressure | |
| Fluid Inlet/Strainer Filter | 20 mesh standard | |
| Air inlet Filter Mesh | 40 Micron | |
| Component B (Resin) Inlet | 3/4 npt(f) swivel | |
| Component A (Isocyanate) Inlet | 3/4 npt(f) swivel | |
| Recirculation/Block Hose Connections | Iso (A) side: #5 JIC (m); Resin (B) side: #6 JIC (m) | |
| Maximum Heated Hose Length*** | 210 ft of 3/8 ID | |
| Weight | 310 lb (140.6 kg) | |
| Wetted Parts | Carbon steel, stainless steel, chrome, aluminum, Fluoroelastomer, PTFE, nylon | |

*Full load amps with all devices operating at maximum capabilities with 210 ft (64.1 m) of hose.

***210 ft (64 m) of heated hose will produce the maximum allowable heat capacity. 310 ft (94 m) of heated hose may be used, but will have 25% less heat capacity.

Graco Standard Warranty

Graco warrants all equipment referenced in this document which is manufactured by Graco and bearing its name to be free from defects in material and workmanship on the date of sale to the original purchaser for use. With the exception of any special, extended, or limited warranty published by Graco, Graco will, for a period of twelve months from the date of sale, repair or replace any part of the equipment determined by Graco to be defective. This warranty applies only when the equipment is installed, operated and maintained in accordance with Graco's written recommendations.

This warranty does not cover, and Graco shall not be liable for general wear and tear, or any malfunction, damage or wear caused by faulty installation, misapplication, abrasion, corrosion, inadequate or improper maintenance, negligence, accident, tampering, or substitution of non-Graco component parts. Nor shall Graco be liable for malfunction, damage or wear caused by the incompatibility of Graco equipment with structures, accessories, equipment or materials not supplied by Graco, or the improper design, manufacture, installation, operation or maintenance of structures, accessories, equipment or materials not supplied by Graco.

This warranty is conditioned upon the prepaid return of the equipment claimed to be defective to an authorized Graco distributor for verification of the claimed defect. If the claimed defect is verified, Graco will repair or replace free of charge any defective parts. The equipment will be returned to the original purchaser transportation prepaid. If inspection of the equipment does not disclose any defect in material or workmanship, repairs will be made at a reasonable charge, which charges may include the costs of parts, labor, and transportation.

THIS WARRANTY IS EXCLUSIVE, AND IS IN LIEU OF ANY OTHER WARRANTIES, EXPRESS OR IMPLIED, INCLUDING BUT NOT LIMITED TO WARRANTY OF MERCHANTABILITY OR WARRANTY OF FITNESS FOR A PARTICULAR PURPOSE.

Graco's sole obligation and buyer's sole remedy for any breach of warranty shall be as set forth above. The buyer agrees that no other remedy (including, but not limited to, incidental or consequential damages for lost profits, lost sales, injury to person or property, or any other incidental or consequential loss) shall be available. Any action for breach of warranty must be brought within two (2) years of the date of sale.

GRACO MAKES NO WARRANTY, AND DISCLAIMS ALL IMPLIED WARRANTIES OF MERCHANTABILITY AND FITNESS FOR A PARTICULAR PURPOSE, IN CONNECTION WITH ACCESSORIES, EQUIPMENT, MATERIALS OR COMPONENTS SOLD BUT NOT MANUFACTURED BY GRACO. These items sold, but not manufactured by Graco (such as electric motors, switches, hose, etc.), are subject to the warranty, if any, of their manufacturer. Graco will provide purchaser with reasonable assistance in making any claim for breach of these warranties.

In no event will Graco be liable for indirect, incidental, special or consequential damages resulting from Graco supplying equipment hereunder, or the furnishing, performance, or use of any products or other goods sold hereto, whether due to a breach of contract, breach of warranty, the negligence of Graco, or otherwise.

FOR GRACO CANADA CUSTOMERS

The Parties acknowledge that they have required that the present document, as well as all documents, notices and legal proceedings entered into, given or instituted pursuant hereto or relating directly or indirectly hereto, be drawn up in English. Les parties reconnaissent avoir convenu que la rédaction du présente document sera en Anglais, ainsi que tous documents, avis et procédures judiciaires exécutés, donnés ou intentés, à la suite de ou en rapport, directement ou indirectement, avec les procédures concernées.

Graco Information

For the latest information about Graco products, visit www.graco.com.

For patent information, see www.graco.com/patents.

TO PLACE AN ORDER, contact your Graco distributor or call to identify the nearest distributor.

Phone: 612-623-6921 or Toll Free: 1-800-328-0211 Fax: 612-378-3505

All written and visual data contained in this document reflects the latest product information available at the time of publication. Graco reserves the right to make changes at any time without notice.

Original instructions. This manual contains English. MM 3A1570

Graco Headquarters: Minneapolis

International Offices: Belgium, China, Japan, Korea

GRACO INC. AND SUBSIDIARIES • P.O. BOX 1441 • MINNEAPOLIS MN 55440-1441 • USA
Copyright 2014, Graco Inc. All Graco manufacturing locations are registered to ISO 9001.

www.graco.com

Revision R, November 2017