

Texture Airless Spray Gun

308491T

EN

27.6 MPa (276 bar, 4000 psi) Maximum Working Pressure

Part No. 241705, Series B

Includes Rac[®] Tip Guard and LTX531 Switch Tip[®]

Part No. 289605 (Europe Only), Series B

Includes Rac[®] Tip Guard and HDA531 Switch Tip[®]



IMPORTANT SAFETY INSTRUCTIONS

Read all warnings and instructions in the repair kit instructions and in the Owners/Operation manual for the sprayer.

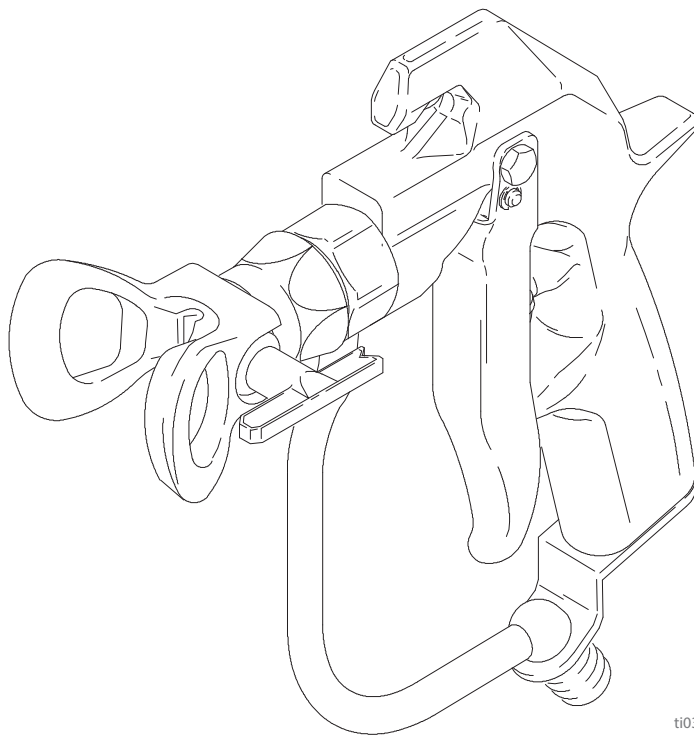

ti03965a

Contents

Warnings	3	Service	10
Installation/Operation	5	Repair Notes	10
System Requirements	5	Disassembly	10
Ground the System	5	Cleaning	11
Pressure Relief Procedure	5	Reassembly	11
How to Use the Gun Trigger Safely	5	Test the Gun Before Regular Use	13
How to Operate the Gun	6	Parts	14
How to Adjust the Spray Pattern	6	Part No. 241705, Series B	
Care of the Spray Tip and Tip Guard	7	Texture Airless Spray Gun	14
How to Flush the Gun	8	Technical Specifications	15
How to Check the Gun Diffuser Operation	9	Graco Standard Warranty	16
		Graco Information	16





Warnings

The following warnings are for the setup, use, grounding, maintenance, and repair of this equipment. The exclamation point symbol alerts you to a general warning and the hazard symbols refer to procedure-specific risks. When these symbols appear in the body of this manual or on warning labels, refer back to these Warnings. Product-specific hazard symbols and warnings not covered in this section may appear throughout the body of this manual where applicable.

 <h1 style="margin: 0;">WARNING</h1>	
	<p>SKIN INJECTION HAZARD</p> <p>High-pressure spray is able to inject toxins into the body and cause serious bodily injury. In the event that injection occurs, get immediate surgical treatment.</p> <ul style="list-style-type: none"> • Do not aim the gun at, or spray any person or animal. • Keep hands and other body parts away from the discharge. For example, do not try to stop leaks with any part of the body. • Always use the nozzle tip guard. Do not spray without nozzle tip guard in place. • Use Graco nozzle tips. • Use caution when cleaning and changing nozzle tips. In the case where the nozzle tip clogs while spraying, follow the Pressure Relief Procedure for turning off the unit and relieving the pressure before removing the nozzle tip to clean. • Equipment maintains pressure after power is shut off. Do not leave the equipment energized or under pressure while unattended. Follow the Pressure Relief Procedure when the equipment is unattended or not in use, and before servicing, cleaning, or removing parts. • Check hoses and parts for signs of damage. Replace any damaged hoses or parts. • This system is capable of producing 4000 psi. Use Graco replacement parts or accessories that are rated a minimum of 4000 psi. • Always engage the trigger lock when not spraying. Verify the trigger lock is functioning properly. • Verify that all connections are secure before operating the unit. • Know how to stop the unit and bleed pressure quickly. Be thoroughly familiar with the controls.
	<p>FIRE AND EXPLOSION HAZARD</p> <p>Flammable fumes, such as solvent and paint fumes, in work area can ignite or explode. Paint or solvent flowing through the equipment can cause static sparking. To help prevent fire and explosion:</p> <ul style="list-style-type: none"> • Use equipment only in well ventilated area. • Eliminate all ignition sources; such as pilot lights, cigarettes, portable electric lamps, and plastic drop cloths (potential static sparking). • Ground all equipment in the work area. See Grounding instructions. • Never spray or flush solvent at high pressure. • Keep work area free of debris, including solvent, rags and gasoline. • Do not plug or unplug power cords, or turn power or light switches on or off when flammable fumes are present. • Use only grounded hoses. • Hold gun firmly to side of grounded pail when triggering into pail. Do not use pail liners unless they are anti-static or conductive. • Stop operation immediately if static sparking occurs or you feel a shock. Do not use equipment until you identify and correct the problem. • Keep a working fire extinguisher in the work area.



WARNING

 	<p>EQUIPMENT MISUSE HAZARD</p> <p>Misuse can cause death or serious injury.</p> <ul style="list-style-type: none"> • Do not operate the unit when fatigued or under the influence of drugs or alcohol. • Do not exceed the maximum working pressure or temperature rating of the lowest rated system component. See Technical Data in all equipment manuals. • Use fluids and solvents that are compatible with equipment wetted parts. See Technical Data in all equipment manuals. Read fluid and solvent manufacturer's warnings. For complete information about your material, request Safety Data Sheet (SDS) from distributor or retailer. • Do not leave the work area while equipment is energized or under pressure. (If applicable.) • Turn off all equipment and follow the Pressure Relief Procedure when equipment is not in use. • Check equipment daily. Repair or replace worn or damaged parts immediately with genuine manufacturer's replacement parts only. • Do not alter or modify equipment. Alterations or modifications may void agency approvals and create safety hazards. • Make sure all equipment is rated and approved for the environment in which you are using it. • Use equipment only for its intended purpose. Call your distributor for information. • Route hoses and cables away from traffic areas, sharp edges, moving parts, and hot surfaces. • Do not kink or over bend hoses or use hoses to pull equipment. • Keep children and animals away from work area. • Comply with all applicable safety regulations.
	<p>TOXIC FLUID OR FUMES HAZARD</p> <p>Toxic fluids or fumes can cause serious injury or death if splashed in the eyes or on skin, inhaled, or swallowed.</p> <ul style="list-style-type: none"> • Read Safety Data Sheet (SDS) to know the specific hazards of the fluids you are using. • Store hazardous fluid in approved containers, and dispose of it according to applicable guidelines.
	<p>RECOIL HAZARD</p> <p>Gun may recoil when triggered. If you are not standing securely, you could fall and be seriously injured.</p>

Installation/Operation

System Requirements

! WARNING

Keep the wallet-sized warning card provided with this gun with the operator at all times. The card contains important treatment information should an injection injury occur. Additional cards are available at no charge from Graco Inc.

1. The pressure drain valve assists in relieving fluid pressure in the displacement pump, hose and gun; triggering the gun to relieve pressure may not be sufficient.
2. Strain the fluid you are spraying if it contains particles which could clog the spray tip.

Ground the System

! WARNING

To reduce the risk of static sparking, ground the pump and all other equipment used or located in the spray area. Check your local electrical code for detailed grounding instructions for your area and type of equipment. Also follow the grounding instructions provided in your pump or sprayer manual. The gun obtains grounding through connection to a properly grounded fluid hose and pump or sprayer. Also read **FIRE OR EXPLOSION HAZARD** on page 3.

Pressure Relief Procedure

! WARNING



To reduce the risk of serious injury, including fluid injection, splashing fluid or solvent in the eyes or on the skin, follow this procedure when you are instructed to relieve pressure, when you stop spraying, shut off the pump, check or service any system equipment, or install, clean or change spray tips.

1. Lock the gun trigger safety.

2. Shut off the power to the pump.
3. Unlock the gun trigger safety
4. Hold the metal part of the gun firmly to a grounded metal pail. Trigger the gun to relieve pressure.
5. Lock the trigger lock safety.
6. Open the drain valve, having a container ready to catch the drainage. Observe the pressure gauge. The gauge reads 0 psi/bar when fully drained. Leave the drain valve open until you are ready to spray again.
7. If you suspect the spray tip or hose is clogged or that pressure has not been fully relieved:
 - a. VERY SLOWLY loosen the spray tip guard retaining nut or the hose end coupling to relieve pressure gradually.
 - b. Loosen the nut or coupling completely.
 - c. Clear airless hose or spray tip obstruction.

How to Use the Gun Trigger Safely

1. To lock the gun trigger safety, turn the safety to a right angle with the gun body.
2. To unlock the gun trigger safety, push the safety out and turn it parallel with the gun body.

	Gun trigger safety shown locked
	Gun trigger safety shown unlocked

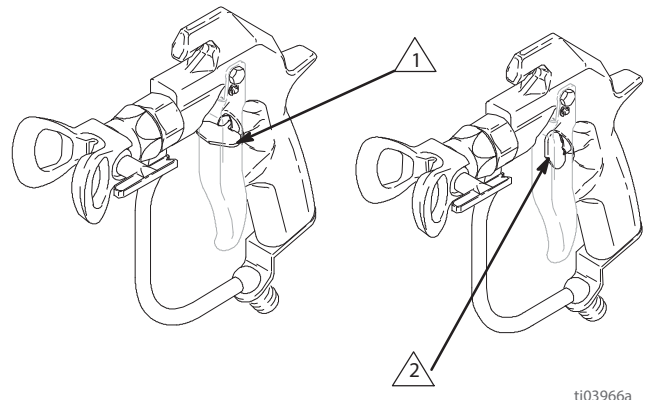

How to Operate the Gun

WARNING

To reduce the risk of component rupture, and serious injury, including fluid injection, do not exceed the gun's **4000 psi (276 bar, 27.6 MPa) Maximum Working Pressure** or the maximum working pressure of lowest rated component in the system.

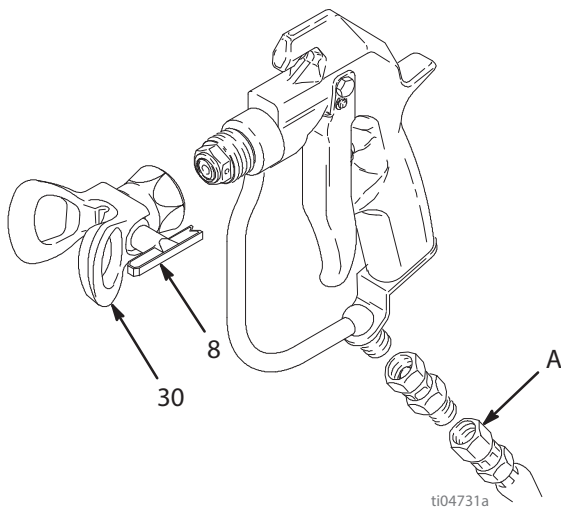

1. Connect an electrically conductive fluid hose (A) to the gun inlet.
2. With no tip installed, start the pump. Flush the pump according to the instructions supplied with it. Use the lowest pressure possible. Prime the system with the material.
3. Relieve pressure.
4. Install the SwitchTip (8) and tip guard (30). Follow the instructions in the manual, supplied.
5. Start the pump. Trigger the gun onto test paper. Adjust the fluid pressure until the spray is completely atomized. Use the lowest pressure necessary to get the desired results. Higher pressure may

not improve the spray pattern and will cause premature tip and pump wear.

6. If adjusting the pressure does not give a good spray pattern, relieve pressure and then try another tip size.
7. Use a full-open, full-close trigger action. Hold the gun about 14 in. (350 mm) from and at right angles to the work surface. Don't swing the gun in an arc. Practice to find the best length and speed of stroke.

How to Adjust the Spray Pattern

1. To adjust the spray pattern direction, relieve pressure. Loosen the tip guard retaining nut (B). Turn the tip guard/tip groove horizontally (C) for a horizontal pattern and vertically (A) for a vertical pattern. Tighten the nut.
2. The spray tip orifice and spray angle determines the coverage and size of pattern. When more coverage is needed, use a larger spray tip rather than increasing fluid pressure.

NOTICE

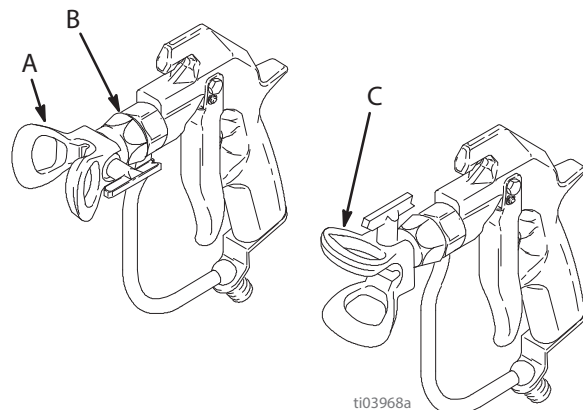

Openings in the tip guard reduce paint buildup on the guard while spraying. Damage to the sharp edges of the openings causes paint to collect at that area. Never hang the gun by the tip guard.



Care of the Spray Tip and Tip Guard

 WARNING	
To reduce the risk of fluid injection or splashing in the eyes or on the skin, do not hold a hand, body or rag in front of the spray tip when cleaning or checking a clogged tip. Point the gun toward the ground or into a waste container when checking to see if the spray tip is cleared.	
Do not try to “blow back” paint; this is not an air spray gun.	
Do not wipe fluid buildup off the gun or spray tip until pressure is relieved.	

Cleaning during the day

 WARNING	
	SKIN INJECTION HAZARD To reduce the risk of serious injury, whenever you are instructed to relieve pressure, follow the How to Operate the Gun page 6.

1. Relieve pressure.
2. Clean the front of the tip frequently during the day to help reduce buildup. Also clean the tip and tip guard at the end of each work day. Use a solvent soaked brush to clean the spray tip.

If the spray tip clogs while spraying

1. Stop spraying immediately.
2. Lock the gun trigger safety. Rotate the tip handle back 180°.
3. Unlock the gun trigger safety. Trigger the gun into a pail or onto the ground to remove the clog.
4. Lock the gun trigger safety. Rotate the tip handle to the spraying position.
5. If the tip is still clogged, engage the gun trigger safety, shut off the sprayer and disconnect the power source, and open the pressure drain valve to relieve pressure. Clean the spray tip as shown in operation manual.

NOTICE
Never soak the entire gun in solvent. Prolonged exposure to solvent can ruin the packings.

	Spraying position shown. Turn handle 180° and trigger gun to clear clog.
---	--

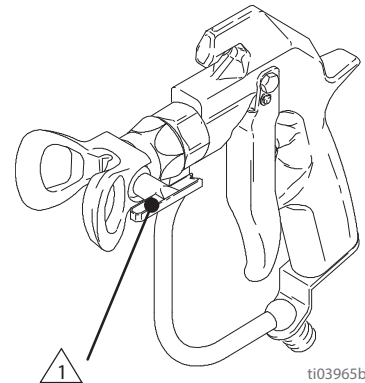

How to Flush the Gun

WARNING

To reduce the risk of fluid injection or splashing in the eyes or on the skin, or static electric discharge when flushing:

- Be sure the entire system, including flushing pails, are properly grounded.
- Remove the tip guard and spray tip.
- Maintain metal to metal contact between the gun and the flushing pail.
- Use the lowest possible pressure

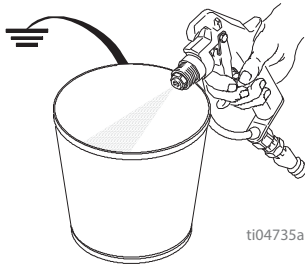

Always flush the pump and gun before the fluid being sprayed can dry in it.

Note: This procedure requires a grounded pail of compatible solvent.

1. Relieve pressure.
2. Remove the tip guard and spray tip. Soak and clean the parts.
3. Remove the pump intake from the original pail.
4. Put the pump intake in a grounded pail of compatible solvent.
5. Start the pump at its lowest pressure.
6. Trigger the gun into the original pail. When solvent appears, release the trigger.
7. Now trigger the gun into the solvent pail. Circulate the fluid until the system is thoroughly flushed.
8. Relieve pressure.

How to Check the Gun Diffuser Operation

The Standard Needle and Seat Kit, 237398, has the number **090** stamped on the needle and seat. The seat **does** have a diffuser.

The optional Non-diffused Needle and Seat Kit, 237260, has the number **125** stamped on the needle and seat. The seat **does not** have a diffuser.

WARNING

The diffuser, located in the valve seat, creates an irregular spray pattern when the gun is sprayed without the tip guard, such as during cleaning. This reduces the risk of an injection injury.

If you are using the optional Kit 237260, you must take extra precautions to keep your hands and body away from the nozzle of the gun.

always have the tip guard in place during regular spraying operations.

Check the diffuser operation weekly. The gun diffuser/seat (2a) breaks up spray and reduces the risk of fluid injection when the tip is not installed. Perform the test below. If it fails, replace the entire Needle and Seat Kit. Diffuser/seats and needles are not sold separately; using old parts with new ones will result in leakage.

WARNING



SKIN INJECTION HAZARD

To reduce the risk of serious injury, whenever you are instructed to relieve pressure, follow the **How to Operate the Gun** page 6.

1. Relieve pressure.
2. Remove the tip guard and spray tip.
3. Start the sprayer and adjust it to the lowest pressure.
4. Aim the gun into a grounded metal pail while holding it firmly to the pail. Trigger the gun. If the fluid emitted **is not** diffused into an irregular stream, replace the entire needle kit immediately



Irregular Spray Pattern.

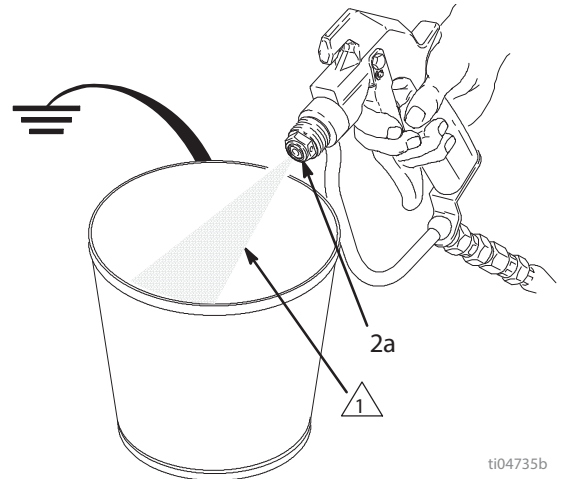

ti04735b

Service



WARNING

To reduce the risk of serious injury from fluid injection or splashing, always follow the **How to Operate the Gun** page 6 before servicing the gun.

Repair Notes

The needle and seat are available only as a kit which includes items 2a to 2e.

The Standard Needle and Seat Kit, 237398, has the number **090** stamped on the needle and seat.

A Non-diffused Needle and Seat Kit, 237260, has the number **125** stamped on the needle and seat. It is recommended only for use with mastics, sealers and other high viscosity materials which have fillers that cannot pass through the standard seat's diffuser.

Use high quality, general purpose grease where grease is indicated.

Disassembly

NOTE: If replacing only the needle and seat, Step 4 and 5 are not required. However, removing them allows you to clean the gun more thoroughly.

1. Relieve pressure
2. Disconnect the fluid hose (A). Remove the tip guard (30). Unscrew the spring screw (21) about 1/4 in. (7 mm) to release spring tension.

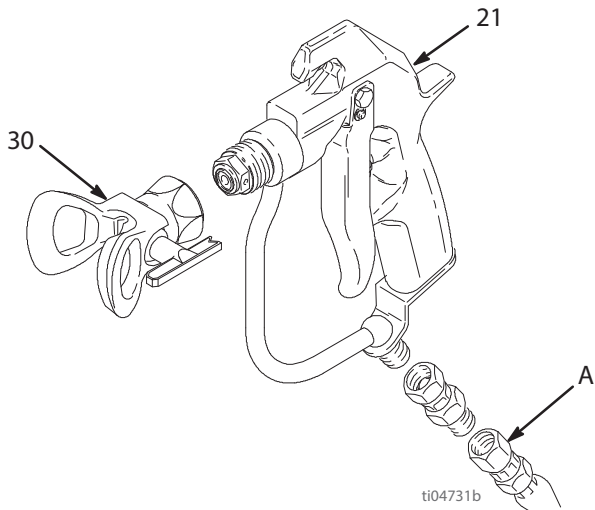

3. Unscrew the valve seat (2a). Remove the gasket (2b).

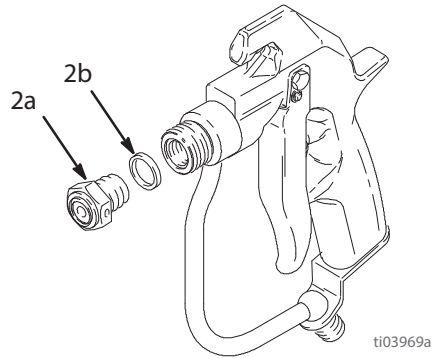

4. Remove one e-clip (27). Push out the pin (18). Remove the screw (29), pivot pin (28), and trigger (25).

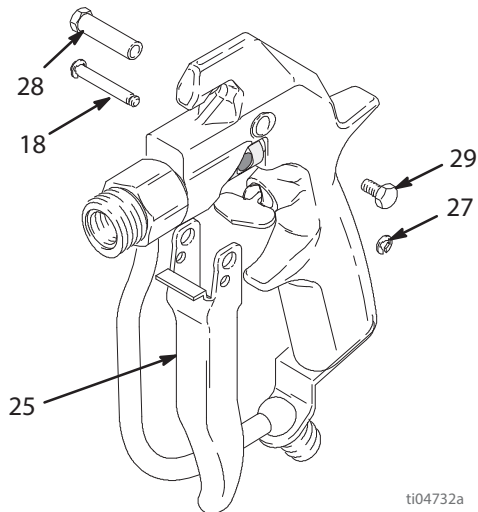

5. Remove the screws (24).

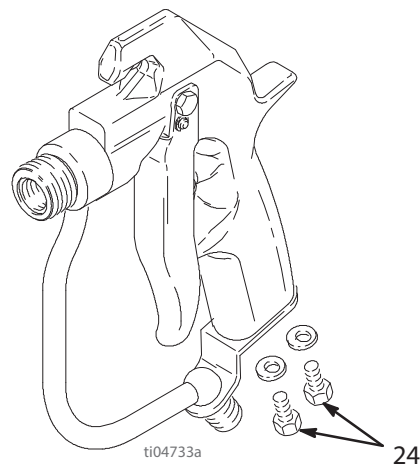

- Loosen the setscrew (15). Pull the fluid housing (22) away from the gun body (1).

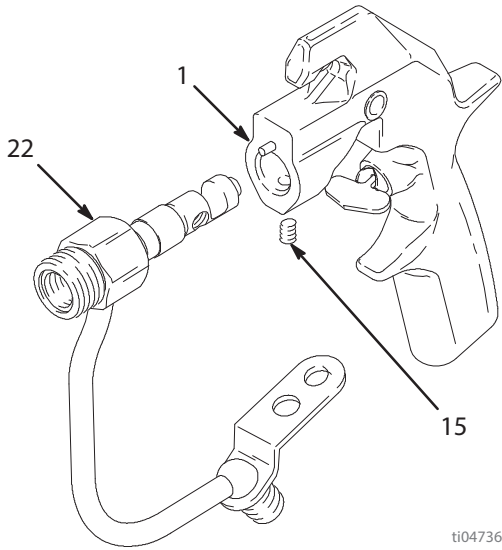

- While supporting the spring guide (16) to prevent bending the needle, loosen the setscrews (17). Remove the spring guide (16).

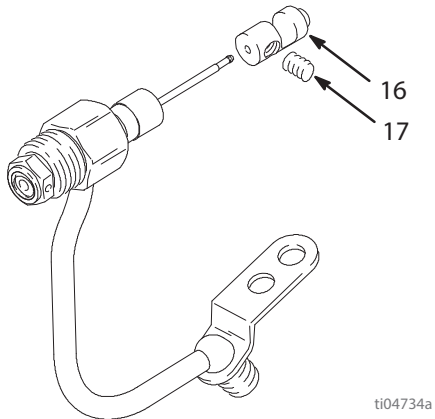

- Remove the needle (2c). Unscrew the seal retainer (2d). Remove the seal (2e).

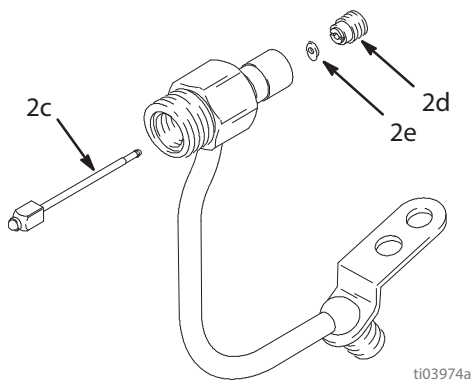

Cleaning

Clean all parts and cavities thoroughly with a compatible solvent. Dry with a rag or compressed air. Replace any parts that are worn or damaged.

Reassembly

- Lightly grease the inner cavities of the fluid housing (22). Install the small seal (2e) so the lips face into the fluid housing cavity. Install the seal retainer (2d) and torque to 30--40 in-lb (3.4--4.5 N.m).

Ref.	Action
1	Torque to 30-40 in-lb (3.4 - 4.5 N.m)
2	Lips of seal must face into housing
3	Grease inner cavity of housing

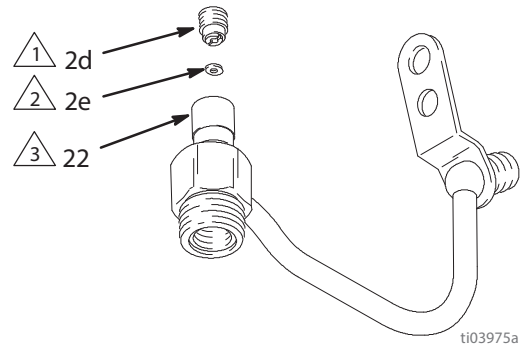

- Lightly grease the small end of the needle (2c) and then guide it into the large end of the fluid housing (22).

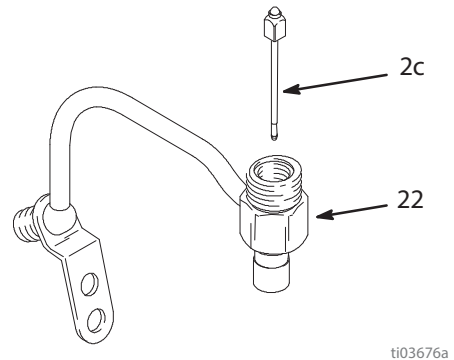

- Place the gasket (2b) on the valve seat (2a). Grease the threads of the valve seat (2a). Screw the valve seat into the fluid housing (22). Torque to 20--25 ft-lb (27--34 N.m).

Ref.	Action
1	Grease the threads
2	Torque to 20-25 ft-lb (27 - 35 N•m)

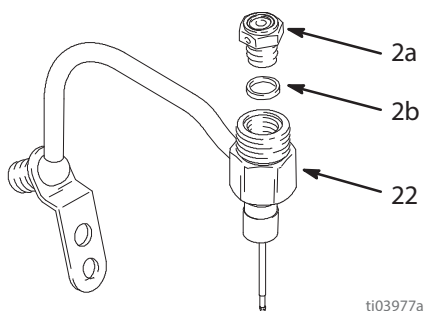

ti03977a

- If the spring (19) was removed, grease the spring adjuster (20) and place the spring. Drop this assembly into the gun body (1).

Ref.	Action
1	Grease this side

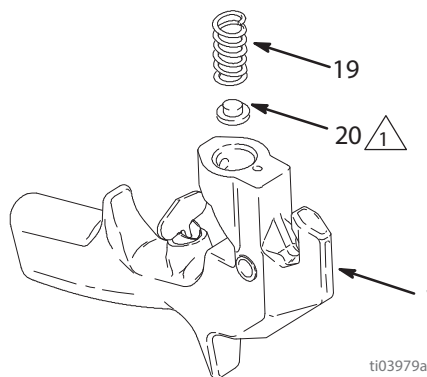

ti03979a

- Install the spring guide (16) and seat it against the needle. Loosely thread both setscrews (17) into the spring guide, then alternately and evenly tighten the setscrews to 10--15 in-lb (1.1--1.6 N.m). Fill the setscrew cavities with petroleum jelly.

Ref.	Action
1	Seat against needle stem
2	Apply light strength Loctite; Torque alternately and evenly to 25-30 in-lb (2.8 - 3.4N•m)
3	Fill cavity with petroleum jelly

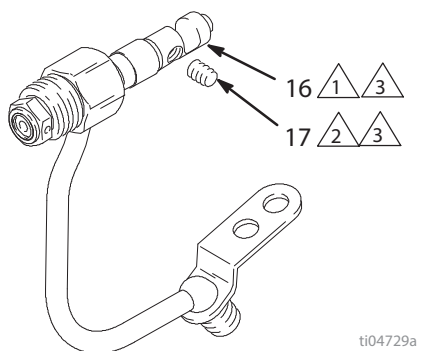

ti04729a

- Push the fluid housing (22) onto the gun body (1) until fully seated. Tighten the setscrew (15) to 30--40 in-lb (3.4--4.5 N.m). Fill the setscrew cavity with petroleum jelly.

Ref.	Action
1	Torque to 30-40 in-lb (3.4 - 4.5 N•m)
2	Fill cavity with petroleum jelly

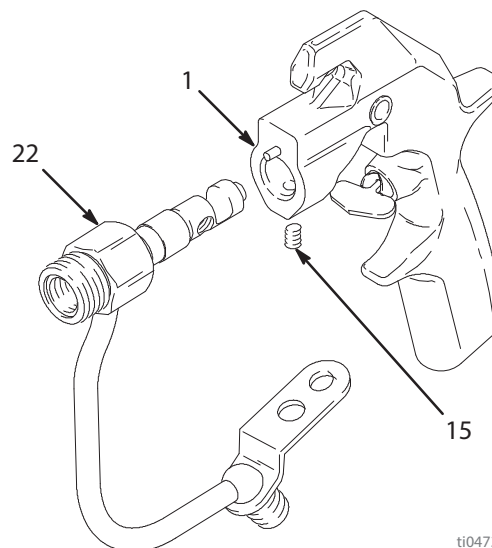

ti04736a

7. Install the screws (24).

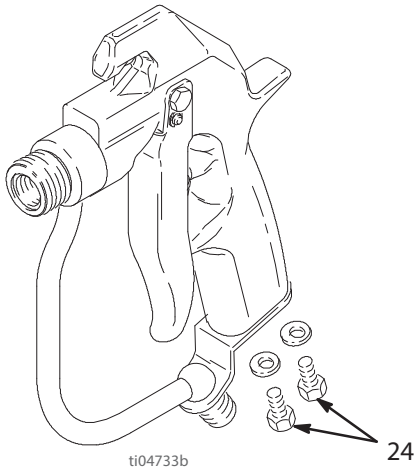

8. Position the trigger (25) on the gun body. Insert the pivot pin (28) into the top hole (A) and secure with the screw (29) on the other side. Place an e-clip (27) on one end of the trigger pin (18). Slide the pin through lower trigger holes and through the slot (B) in the spring guide (16) (turn the spring guide to align, as needed). Install the other e-clip (27).

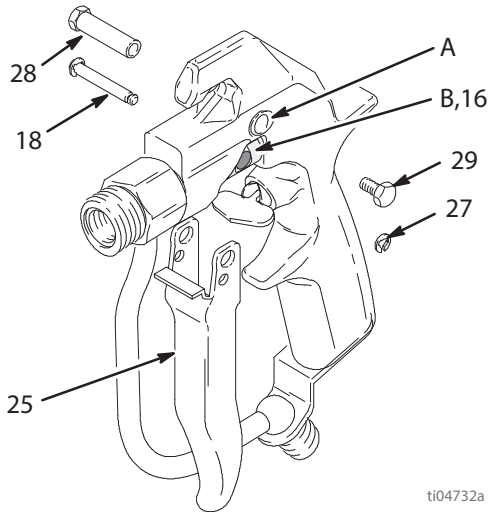

9. If it was removed, install the spring tension screw (21) at the rear of the gun. Then, turn the screw in until it stops.

Ref.	Action
1	Turn in until screw stops

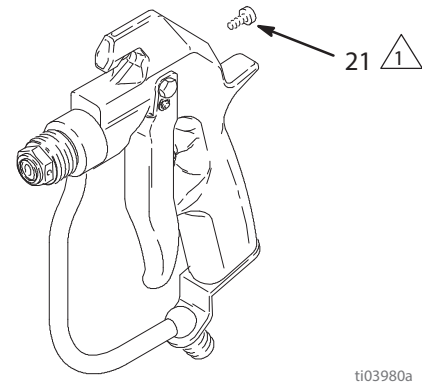

Test the Gun Before Regular Use

1. Lock the gun trigger safety. Connect a hose to the gun. Start and prime the pump.
2. Release the gun trigger safety. Trigger the gun into a waste container. Release the trigger to be sure the gun immediately stops spraying and that there are no leaks.
3. If the gun has a diffuser, check the diffuser using the procedure on page 9.
4. Install the tip guard (30) before regular use.

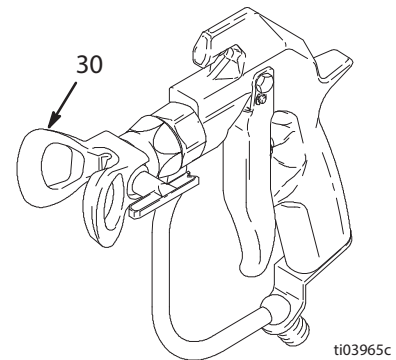

Parts

Part No. 241705, Series B Texture Airless Spray Gun

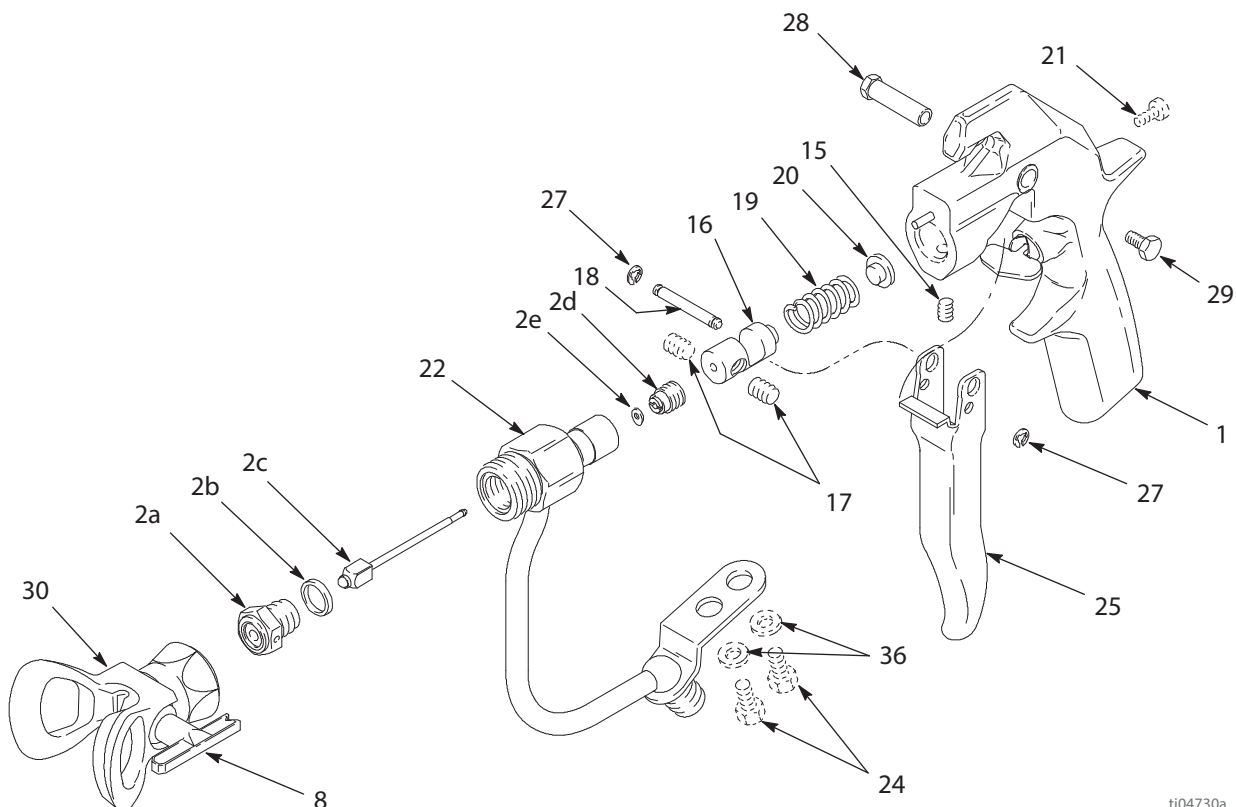

ti04730a

Ref.	Part	Description	Qty.	Ref.	Part	Description	Qty.
1	237680	TEXTURE GUN BODY	1	20	189990	SPRING ADJUSTER	1
2	237260	NEEDLE AND SEAK KIT (<i>parts not sold separately</i>)	1	21	110637	ADJUSTING SCREW	1
2a		VALVE SEAT	1	22	24R913	FLUID HOUSING	1
2b		GASKET	1	24	112774	SCREW, 1/4-20	2
2c		NEEDLE	1	25	189974	GUN TRIGGER	1
2d		SEAL RETAINER	1	27	112410	E-CLIP	2
2e		SEAL	1	28	187965	PIVOT PIN	1
8	LTX531	Switch Tip, size 531 (Model 241705)	1	29	203953	SCREW, HWH, 10-24	1
	HDA531	Switch Tip, size 531 (Model 289605)	1	30	246215	KIT, TIP GUARD	1
15	102207	SETSCREW, 1/4-20	1	35▲	222385	WARNING CARD <i>not shown</i>	1
16	189960	SPRING GUIDE	1	36	110755	WASHER, FLAT	2
17	112729	SETSCREW, socket head	2				
18	189958	TRIGGER PIN	1				
19	102924	SPRING	1				

▲Replacement Danger and Warning labels, tags, and cards are available at no cost.

Technical Specifications

	U.S.	Metric
Dimensions		
Height	8.0 in.	203 mm
Length	8.25 in.	210 mm
Weight (includes tip and tip guard)	25.7 oz	720 g
Spray Gun		
Maximum working pressure	4000 psi	27.6 MPa (276 bar)
Fluid orifice size	0.125 in.	3.2 mm
Inlet size	1/4 npt (m)	1/4 npt (m)
Fluid tube inside diameter	0.245 in.	6.2 mm
Sound Data		
Sound Pressure Level	84 dB(A)*	
Sound Power Level	93 dB(A)*	
* - Measured while spraying waterbase paint through a 0.031 tip at 3000 psi (20.7 MPa, 207 bar), per ISO 3744.		
Wetted parts: Tungsten carbide, 17-4PH passivated stainless steel, polypropylene, polyethylene		

Loctite® is a registered trademark of the Loctite Corporation

Graco Standard Warranty

Graco warrants all equipment referenced in this document which is manufactured by Graco and bearing its name to be free from defects in material and workmanship on the date of sale to the original purchaser for use. With the exception of any special, extended, or limited warranty published by Graco, Graco will, for a period of twelve months from the date of sale, repair or replace any part of the equipment determined by Graco to be defective. This warranty applies only when the equipment is installed, operated and maintained in accordance with Graco's written recommendations.

This warranty does not cover, and Graco shall not be liable for general wear and tear, or any malfunction, damage or wear caused by faulty installation, misapplication, abrasion, corrosion, inadequate or improper maintenance, negligence, accident, tampering, or substitution of non-Graco component parts. Nor shall Graco be liable for malfunction, damage or wear caused by the incompatibility of Graco equipment with structures, accessories, equipment or materials not supplied by Graco, or the improper design, manufacture, installation, operation or maintenance of structures, accessories, equipment or materials not supplied by Graco.

This warranty is conditioned upon the prepaid return of the equipment claimed to be defective to an authorized Graco distributor for verification of the claimed defect. If the claimed defect is verified, Graco will repair or replace free of charge any defective parts. The equipment will be returned to the original purchaser transportation prepaid. If inspection of the equipment does not disclose any defect in material or workmanship, repairs will be made at a reasonable charge, which charges may include the costs of parts, labor, and transportation.

THIS WARRANTY IS EXCLUSIVE, AND IS IN LIEU OF ANY OTHER WARRANTIES, EXPRESS OR IMPLIED, INCLUDING BUT NOT LIMITED TO WARRANTY OF MERCHANTABILITY OR WARRANTY OF FITNESS FOR A PARTICULAR PURPOSE.

Graco's sole obligation and buyer's sole remedy for any breach of warranty shall be as set forth above. The buyer agrees that no other remedy (including, but not limited to, incidental or consequential damages for lost profits, lost sales, injury to person or property, or any other incidental or consequential loss) shall be available. Any action for breach of warranty must be brought within two (2) years of the date of sale.

GRACO MAKES NO WARRANTY, AND DISCLAIMS ALL IMPLIED WARRANTIES OF MERCHANTABILITY AND FITNESS FOR A PARTICULAR PURPOSE, IN CONNECTION WITH ACCESSORIES, EQUIPMENT, MATERIALS OR COMPONENTS SOLD BUT NOT MANUFACTURED BY GRACO. These items sold, but not manufactured by Graco (such as electric motors, switches, hose, etc.), are subject to the warranty, if any, of their manufacturer. Graco will provide purchaser with reasonable assistance in making any claim for breach of these warranties.

In no event will Graco be liable for indirect, incidental, special or consequential damages resulting from Graco supplying equipment hereunder, or the furnishing, performance, or use of any products or other goods sold hereto, whether due to a breach of contract, breach of warranty, the negligence of Graco, or otherwise.

Graco Information

For the latest information about Graco products, visit www.graco.com.

For patent information, see www.graco.com/patents.

TO PLACE AN ORDER, contact your Graco distributor or call 1-800-690-2894 to identify the nearest distributor.

*All written and visual data contained in this document reflects the latest product information available at the time of publication.
Graco reserves the right to make changes at any time without notice.*

For patent information, see www.graco.com/patents. Original instructions. This manual contains English. MM 308491

Graco Headquarters: Minneapolis/International Offices: Belgium, China, Japan, Korea

GRACO INC. AND SUBSIDIARIES • P.O. BOX 1441 • MINNEAPOLIS MN 55440-1441 • USA

Copyright 1995, Graco Inc. All Graco manufacturing locations are registered to ISO 9001.

www.graco.com

Revision T - April 2016