

LineLazer™ IV 3900, R300, 5900, and FieldLazer R300 Airless Line Stripers

311020Z

EN

- For application of line striping materials -

3300 psi (22.8 MPa, 228 bar) Maximum Working Pressure



Important Safety Instructions

Read all warnings and instructions in this manual and in **LineLazer**, **FieldLazer Operation** manual. Be familiar with the controls and the proper usage of the equipment. Save these instructions



311017

312540

310643



311254



309055



311049

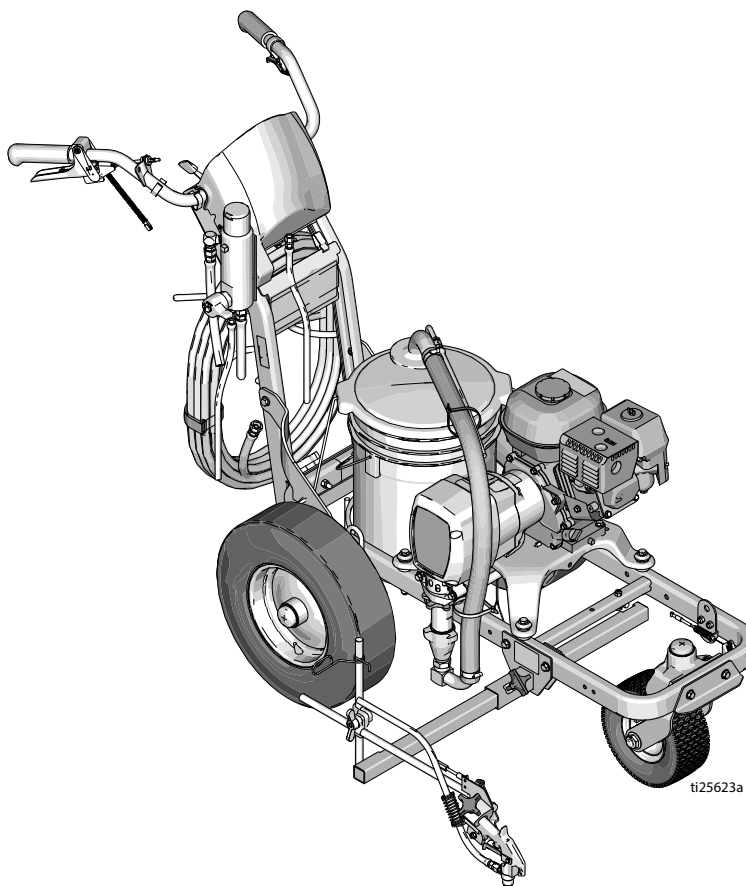







Contents







Models	3	Distance Sensor Adjustment	19
3900	3	Gear Alignment	19
R300	3	Sensor Height Adjustment	19
5900	3	Control Board Diagnostics	20
Warnings	4	Digital Display Messages	20
Tip Selection	6	Displacement Pump	21
Maintenance	7	Removal	21
Pressure Relief Procedure	7	Parts - LineLazer IV	22
Troubleshooting	8	Parts - Drive and Pinion Housing Assemblies ..	23
Bearing Housing and Connecting Rod	11	Parts Drawing - LineLazer IV	24
Removal	11	Parts List - LineLazer IV	25
Installation	11	Parts Drawing - Line Lazer IV	26
Drive Housing	12	Models 248862, 248866	26
Removal	12	Parts List - LineLazer IV	27
Installation	12	Parts Drawing - LineLazer IV	28
Pinion Assembly/Clutch Armature/Clamp	13	Models 248862, 248866	28
Clutch Housing	15	Parts List - LineLazer IV	29
Removal	15	Models 248862, 248866	29
Engine	16	Parts Drawing - LineLazer IV	30
Removal	16	Models 248862, 248866	30
Pressure Control	17	Parts List - LineLazer IV	31
On/Off Switch	17	Models 248862, 248866	31
Pressure Control	18	Parts Drawing - LineLazer IV	32
Control Board	18	Models 248862, 248866	32
Installation	18	Parts List - LineLazer IV	33
Pressure Control Transducer	18	Models 248862, 248866	33
Installation	18	Pressure Control Wiring Diagram	34
Pressure Adjust Potentiometer	18	Technical Data	35
Installation	18	Dimensions	36
Trigger Sensor Adjustment	19	Notes	37
		Graco Standard Warranty	38

Models





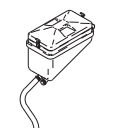
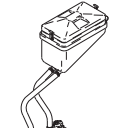

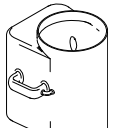
3900

						
248862	✓		✓	✓		
248863		✓	✓			
249008	✓					
249009		✓				
248864	✓		✓		✓	
248865		✓	✓			✓

R300





								
24M605	✓		✓				✓	✓
24M607	✓		✓					

5900



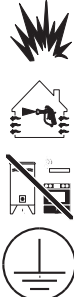



						
248866	✓		✓	✓		
248867		✓	✓			
249010	✓					
249011		✓				
248868	✓		✓		✓	
248869		✓	✓			✓

Warnings





The following warnings are for the setup, use, grounding, maintenance, and repair of this equipment. The exclamation point symbol alerts you to a general warning and the hazard symbols refer to procedure-specific risks. When these symbols appear in the body of this manual or on warning labels, refer back to these Warnings. Product-specific hazard symbols and warnings not covered in this section may appear throughout the body of this manual where applicable.

 WARNING	
	<p>FIRE AND EXPLOSION HAZARD Flammable fumes, such as solvent and paint fumes, in work area can ignite or explode. To help prevent fire and explosion:</p> <ul style="list-style-type: none"> • Use equipment only in well ventilated area. • Do not fill fuel tank while engine is running or hot; shut off engine and let it cool. Fuel is flammable and can ignite or explode if spilled on hot surface. • Eliminate all ignition sources; such as pilot lights, cigarettes, portable electric lamps, and plastic drop cloths (potential static arc). • Keep work area free of debris, including solvent, rags and gasoline. • Do not plug or unplug power cords, or turn power or light switches on or off when flammable fumes are present. • Ground equipment and conductive objects in work area. See Grounding instructions. • Use only grounded hoses. • Hold gun firmly to side of grounded pail when triggering into pail. • Stop operation immediately if there is static sparking or you feel a shock. Do not use equipment until you identify and correct the problem. • Keep a fire extinguisher in work area.
	<p>CARBON MONOXIDE HAZARD Exhaust contains poisonous carbon monoxide, which is colorless and odorless. Breathing carbon monoxide can cause death.</p> <ul style="list-style-type: none"> • Do not operate in an enclosed area.
	<p>SKIN INJECTION HAZARD High-pressure fluid from gun, hose leaks, or ruptured components will pierce skin. This may look like just a cut, but it is a serious injury that can result in amputation. Get immediate surgical treatment.</p> <ul style="list-style-type: none"> • Do not spray without tip guard and trigger guard installed. • Engage trigger lock when not spraying. • Do not point gun at anyone or at any part of the body. • Do not put your hand over the spray tip. • Do not stop or deflect leaks with your hand, body, glove, or rag. • Follow Pressure Relief Procedure when you stop spraying and before cleaning, checking, or servicing equipment. • Tighten all fluid connections before operating the equipment. • Check hoses and couplings daily. Replace worn or damaged parts immediately.
	<p>PRESSURIZED EQUIPMENT HAZARD Fluid from the gun/dispense valve, leaks, or ruptured components can splash in the eyes or on skin and cause serious injury.</p> <ul style="list-style-type: none"> • Follow Pressure Relief Procedure in this manual, when you stop spraying and before cleaning, checking, or servicing equipment. • Tighten all fluid connections before operating the equipment. • Check hoses, tubes, and couplings daily. Replace worn or damaged parts immediately.

! WARNING

	<p>PRESSURIZED ALUMINUM PARTS HAZARD</p> <p>Use of fluids that are incompatible with aluminum in pressurized equipment can cause serious chemical reaction and equipment rupture. Failure to follow this warning can result in death, serious injury, or property damage.</p> <ul style="list-style-type: none"> • Do not use 1,1,1-trichloroethane, methylene chloride, other halogenated hydrocarbon solvents or fluids containing such solvents • Do not use chlorine bleach. • Many other fluids may contain chemicals that can react with aluminum. Contact your material supplier for compatibility.
	<p>EQUIPMENT MISUSE HAZARD</p> <p>Misuse can cause death or serious injury.</p> <ul style="list-style-type: none"> • Do not operate the unit when fatigued or under the influence of drugs or alcohol. • Do not exceed the maximum working pressure or temperature rating of the lowest rated system component. See Technical Data in all equipment manuals. • Use fluids and solvents that are compatible with equipment wetted parts. See Technical Data in all equipment manuals. Read fluid and solvent manufacturer's warnings. For complete information about your material, request MSDS from distributor or retailer. • Do not leave the work area while equipment is energized or under pressure. • Turn off all equipment and follow the Pressure Relief Procedure when equipment is not in use. • Check equipment daily. Repair or replace worn or damaged parts immediately with genuine manufacturer's replacement parts only. • Do not alter or modify equipment. Alterations or modifications may void agency approvals and create safety hazards. • Make sure all equipment is rated and approved for the environment in which you are using it. • Use equipment only for its intended purpose. Call your distributor for information. • Route hoses and cables away from traffic areas, sharp edges, moving parts, and hot surfaces. • Do not kink or ever bend hoses or use hoses to pull equipment. • Keep children and animals away from work area. • Comply with all applicable safety regulations.
	<p>BURN HAZARD</p> <p>Equipment surfaces and fluid that's heated can become very hot during operation. To avoid severe burns:</p> <ul style="list-style-type: none"> • Do not touch hot fluid or equipment.
	<p>MOVING PARTS HAZARD</p> <p>Moving parts can pinch, cut or amputate fingers and other body parts.</p> <ul style="list-style-type: none"> • Keep clear of moving parts. • Do not operate equipment with protective guards or covers removed. • Pressurized equipment can start without warning. Before checking, moving, or servicing equipment, follow the Pressure Relief Procedure and disconnect all power sources.
	<p>PERSONAL PROTECTIVE EQUIPMENT</p> <p>Wear appropriate protective equipment when in the work area to help prevent serious injury, including eye injury, hearing loss, inhalation of toxic fumes, and burns. Protective equipment includes but is not limited to:</p> <ul style="list-style-type: none"> • Protective eyewear, and hearing protection • Respirators, protective clothing, and gloves as recommended by the fluid and solvent manufacturer.
	<p>RECOIL HAZARD</p> <p>Gun may recoil when triggered. If you are not standing securely, you could fall and be seriously injured.</p>
	<p>CALIFORNIA PROPOSITION 65</p> <p>The engine exhaust from this product contains a chemical known to the State of California to cause cancer, birth defects or other reproductive harm.</p> <p>This product contains a chemical known to the State of California to cause cancer, birth defects or other reproductive harm. Wash hands after handling.</p>

Tip Selection

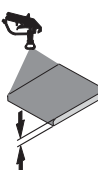
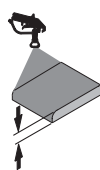
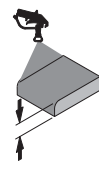
	 in. (cm)	 in. (cm)	 in. (cm)	 in. (cm)			
LL5213*	2 (5)				✓		
LL5215*	2 (5)					✓	
LL5217		4 (10)				✓	
LL5219		4 (10)					✓
LL5315		4 (10)			✓		
LL5317		4 (10)			✓		
LL5319		4 (10)				✓	
LL5321		4 (10)				✓	
LL5323		4 (10)				✓	
LL5325		4 (10)					✓
LL5327		4 (10)					✓
LL5329		4 (10)					✓
LL5331		4 (10)					✓
LL5333		4 (10)					✓
LL5335		4 (10)					✓
LL5355		4 (10)					✓
LL5417			6 (15)		✓		
LL5419			6 (15)		✓		
LL5421			6 (15)		✓		
LL5423			6 (15)			✓	
LL5425			6 (15)			✓	
LL5427			6 (15)			✓	
LL5429			6 (15)			✓	
LL5431			6 (15)				✓
LL5435			6 (15)				✓
LL5621				12 (30)	✓		
LL5623				12 (30)	✓		
LL5625				12 (30)	✓		
LL5627				12 (30)	✓		
LL5629				12 (30)	✓		
LL5631				12 (30)		✓	
LL5635				12 (30)		✓	
LL5639				12 (30)			✓

Use 100 mesh filter to reduce tip clogs.

Maintenance

Pressure Relief Procedure



Follow the Pressure Relief Procedure whenever you see this symbol.



This equipment stays pressurized until pressure is manually relieved. To help prevent serious injury from pressurized fluid, such as skin injection, splashing fluid and moving parts, follow the Pressure Relief Procedure when you stop spraying and before cleaning, checking, or servicing the equipment.

1. Engage trigger lock.
2. Close the bleed-type master air valve.
3. Disengage the trigger lock.
4. Hold a metal part of the gun firmly to a grounded metal pail. Trigger the gun to relieve pressure.
5. Engage the trigger lock.
6. Open all fluid drain valves in the system, having a waste container ready to catch drainage. Leave drain valve(s) open until you are ready to spray again.
7. If you suspect the spray tip or hose is clogged or that pressure has not been fully relieved:
 - a. VERY SLOWLY loosen tip guard retaining nut or hose end coupling to relieve pressure gradually.
 - b. Loosen nut or coupling completely.
 - c. Clear hose or tip obstruction.

NOTICE

Minimum hose size allowable for proper sprayer operation is 3/8 in. x 50 ft.

For detailed engine maintenance and specifications, refer to separate Honda Engine's Owner's Manual, supplied.

DAILY: Check engine oil level and fill as necessary.

DAILY: Check hose for wear and damage.

DAILY: Check gun safety for proper operation.

DAILY: Check pressure drain valve for proper operation.

DAILY: Check and fill the gas tank.

AFTER THE FIRST 20 HOURS OF OPERATION:

Drain engine oil and refill with clean oil. Reference Honda Engines Owner's Manual for correct oil viscosity.

WEEKLY: Remove air filter cover and clean element. Replace element, if necessary. If operating in an unusually dusty environment: check filter daily and replace, if necessary.

Replacement elements can be purchased from your local HONDA dealer.

WEEKLY: Check level of TSL in displacement pump packing nut. Fill nut, if necessary. Keep TSL in nut to help prevent fluid buildup on piston rod and premature wear of packings.

AFTER EACH 100 HOURS OF OPERATION:

Change engine oil. Reference Honda Engines Owner's Manual for correct oil viscosity.

SPARK PLUG: Use only BPR6ES (NGK) or W20EPR--U (NIPPONDENSO) plug. Gap plug to 0.028 to 0.031 in. (0.7 to 0.8 mm). Use spark plug wrench when installing and removing plug.

Caster Wheel

(See letter call-outs in Parts drawing on page 28)

1. Once each year, tighten nut (127) under dust cap (142) until spring washer bottoms out. Then back off the nut 1/2 to 3/4 turn.
2. Once each year, tighten nut (127) on screw (131) until it begins to compress spring washer. Then tighten the nut an additional 1/4 turn.
3. Once each month, grease the wheel bearing (F).
4. Check pin (55) for wear. If pin is worn out, there will be play in the caster wheel. Reverse or replace the pin as needed.
5. Check caster wheel alignment as necessary. To align: loosen screw (145), align wheel and tighten screw.

Troubleshooting



Problem	Cause	Solution
E=XX is displayed	Fault condition exists	Determine fault correction from table, page 20.
Engine won't start	Engine switch is OFF	Turn engine switch ON
	Engine is out of gas	Refill gas tank. Honda Engines Owner's Manual.
	Engine oil level is low	Try to start engine. Replenish oil, if necessary. Honda Engines Owner's Manual.
	Spark plug cable is disconnected or damaged	Connect spark plug cable or replace spark plug
	Cold engine	Use choke
	Fuel shutoff lever is OFF	Move lever to ON position
	Oil is seeping into combustion chamber	Remove spark plug. Pull starter 3 to 4 times. Clean or replace spark plug. Start engine. Keep sprayer upright to avoid oil seepage.
Engine operates, but displacement pump does not operate	Error code displayed?	Reference pressure control repair. Page 18.
	Pump switch is OFF	Turn pump switch ON.
	Pressure setting is too low	Turn pressure adjusting knob clockwise to increase pressure.
	Fluid filter (11) is dirty	Clean filter. Page 32.
	Tip or tip filter is clogged	Clean tip or tip filter. See spray gun manual.
	Displacement pump piston rod is stuck due to dried paint	Repair pump. See pump manual.
	Connecting rod is worn or damaged	Replace connecting rod. Page 11.
	Drive housing is worn or damaged	Replace drive housing. Page 12.
	Electrical power is not energizing clutch field	<p>Check wiring connections. Page 16. Reference pressure control repair. Page 18. Reference wiring diagram. Page 34.</p> <p>With pump switch ON and pressure turned to MAXIMUM, use a test light to check for power between clutch test points on control board.</p> <p>Measure resistance across clutch coil. At 70° F, the resistance must be between 1.2 ±0.2Ω (LineLazer IV 3900/R300); 1.7 ±0.2Ω (LineLazer IV 5900); if not, replace pinion housing.</p> <p>Have pressure control checked by authorized Graco dealer.</p>
Clutch is worn, damaged, or incorrectly positioned	Replace clutch. Page 13.	

Problem	Cause	Solution
	Pinion assembly is worn or damaged	Repair or replace pinion assembly. Page 13.
Pump output is low	Strainer (34f) is clogged	Clean strainer.
	Piston ball is not seating	Service piston ball. See pump manual.
	Piston packings are worn or damaged	Replace packings. See pump manual.
	O-ring in pump is worn or damaged	Replace o-ring. See pump manual.
	Intake valve ball is not seating properly	Clean intake valve. See pump manual.
	Intake valve ball is packed with material	Clean intake valve. See pump manual.
	Engine speed is too low	Increase throttle setting. See operation manual.
	Clutch is worn or damaged	Replace clutch. Page 13.
	Pressure setting is too low	Increase pressure. See operation manual.
	Fluid filter (11), tip filter or tip is clogged or dirty	Clean filter. See operation or spray gun manual.
	Large pressure drop in hose with heavy materials	Use larger diameter hose and/or reduce overall
		length of hose. Use of more than 100 ft of 1/4 in. hose significantly reduces performance of sprayer. Use 3/8 in. hose for optimum performance (50 ft minimum).
Excessive paint leakage into throat packing nut	Throat packing nut is loose	Remove throat packing nut spacer. Tighten throat packing nut just enough to stop leakage.
	Throat packings are worn or damaged	Replace packings. See pump manual.
	Displacement rod is worn or damaged	Replace rod. See pump manual.
Fluid is spitting from gun	Air in pump or hose	Check and tighten all fluid connections. Reprime pump. See operation manual.
	Tip is partially clogged	Clear tip. See spray gun manual.
	Fluid supply is low or empty	Refill fluid supply. Prime pump. See operation manual. Check fluid supply often to prevent running pump dry.
Pump is difficult to prime	Air in pump or hose	Check and tighten all fluid connections. Reduce engine speed and cycle pump as slowly as possible during priming.
	Intake valve is leaking	Clean intake valve. Be sure ball seat is not nicked or worn and that ball seats well. Reassemble
	Pump packings are worn	Replace pump packings. See pump manual.
	Paint is too thick	Thin the paint according to the supplier's recommendations
	Engine speed is too high	Decrease throttle setting before priming pump. See operation manual.
Clutch squeaks each time clutch engages	Clutch surfaces are not matched to each other when new and may cause noise	Clutch surfaces need to wear into each other. Noise will dissipate after a day of run time.
High engine speed at no load	Misadjusted throttle setting	Reset throttle to 3600 engine rpm at no load
	Worn engine governor	Replace or service engine governor

Problem	Cause	Solution
Gallon counter not working	Broken or disconnected wire	Check wires and connections. Replace broken wires.
	Bad sensor	Replace sensor
	Missing magnet	Reposition or replace magnet.
Sprayer operates, but display does not	Bad connection between control board and display	Remove display and reconnect
	Display damaged	Replace display
Distance counter not operating properly	Trigger sensor not set correctly	See "Spray icon does not show on display when fluid is sprayed"
	Bad wiring connections	Check connector, and reconnect
	Distance sensor not spaced correctly from gear	Adjust space between sensor and gear to .050 --/+ .020 in. See page 19.
	Distance sensor and gear not aligned	Remove tire, and press in or pull out gear to align sensor and gear.
	Gear teeth missing or damaged.	Replace distance gear/wheel
	Wire cracked or broken	Replace sensor
Miles not calculating	Distance sensor	See "Distance counter not operating properly"
	Trigger sensor	See "Spray icon does not show on display when fluid is sprayed"
	Gallon counter	See "Gallon counter not working"
	Bad or damaged control board	Replace control board
Fluid spray starts after spray icon is shown on display	Interrupter (164) is improperly positioned	Turn screw (126) counterclockwise until spray icon synchronizes with fluid spray
Fluid spray starts before spray icon is shown on display	Interrupter (164) is improperly positioned	Turn screw (126) clockwise until spray icon is synchronized with fluid spray
Spray icon does not show on display when fluid is sprayed	Loose connector	Check connector and reconnect
	Interrupter (164) is improperly positioned	Turn screw (126) counterclockwise until spray icon synchronizes with fluid spray
	Reed switch assembly (166) is damaged	Replace reed switch assembly (166)
	Magnet on assembly (166) is missing	Replace reed switch assembly (166)
	Cut or sliced wire	Replace distance sensor harness (66)
	Control board is damaged	Replace control board
	Display is damaged	Replace display
	Interrupter (164) is improperly positioned	Turn screw (126) clockwise until spray icon is synchronized with fluid spray
Reed switch assembly (166) is damaged	Replace reed switch assembly (166)	

Bearing Housing and Connecting Rod

Removal



- 1 Relieve pressure, page 7.
- 2 Fig. 2. Remove screws (187) and front cover (83).
- 3 Unscrew suction tub (34) from pump, hold wrench on pump intake valve (A) to keep pump from loosening.
- 4 Disconnect pump outlet hose (100) from displacement pump outlet nipple (60).
- 5 Fig. 1. Use screwdriver to push up retaining spring (236) at top of pump. Push out pin (235).

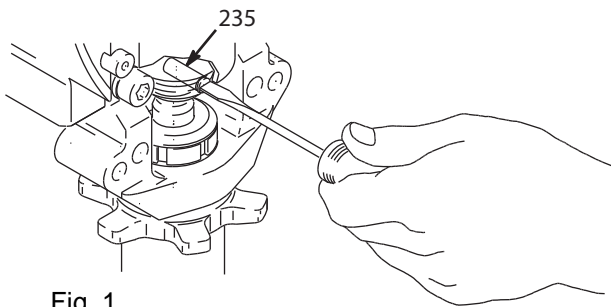

Fig. 1

7675B

- 6 Fig. 2. Loosen retaining nut (84). Unscrew and remove displacement pump (21).
- 7 Remove four screws (183) and lock-washers (173) from bearing housing (22).
- 8 Pull connecting rod (26) and lightly tap lower rear of bearing housing (22) with plastic mallet to loosen from drive housing (24). Pull bearing housing and connecting rod assembly (26) off drive housing.
- 9 Inspect crank (B) for excessive wear and replace parts as needed.

Installation

- 1 Evenly lubricate inside of bronze bearing (C) in bearing housing (22) with high-quality motor oil. Liberally pack top roller bearing (E), lower bearing (D) inside connecting rod assembly (26) with bearing grease.
- 2 Assemble connecting rod (26) and bearing housing (22).

- 3 Clean mating surfaces of bearing and drive housings.
- 4 Align connecting rod with crank (B) and carefully align locating pins (F) in driving housing (24) with holes in bearing housing (22). Push bearing housing onto drive housing or tap into place with plastic mallet.

NOTICE

To prevent damage to soft key buttons, do not press the buttons with sharp objects such as pens, plastic cards, or fingernails.

- 5 Install screws (183) and lock-washers (173) on bearing housing. Torque evenly, referencing note 3 value in Fig. 2.
- 6 Install pump. Refer to **Displacement Pump, Installation**, page 21.

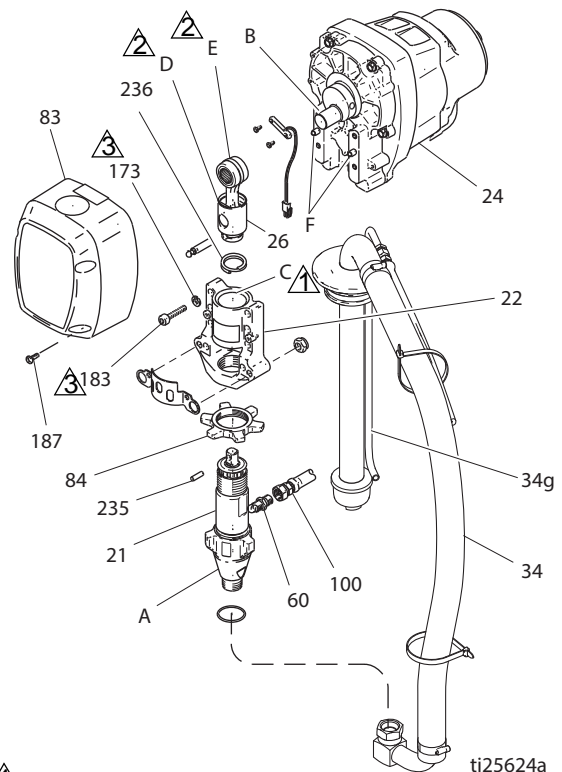

Fig. 2

Model 248862 shown

Drive Housing

Removal



- 1 Relieve pressure, page 7.
- 2 Fig. 3. Remove bearing housing. Refer to **Bearing Housing and Connecting Rod** procedure on page 11.
- 3 Remove two screws (158) and reed switch (182).
- 4 Remove six screws (189) and reed switch (25).
- 5 Lightly tap around drive housing (24) to loosen drive housing. Pull drive housing straight off pinion housing. Be prepared to support gear cluster (23), which may also come out.

Installation

- 1 Liberally apply bearing grease (supplied with replacement gear cluster) to gear cluster (23) and to areas called out by reference 2 in Fig. 3.
- 2 Place bronze colored washer (24g) on shaft protruding from large shaft of drive housing (24). Place silver colored washer (24h) on pinion housing. Clean mating surfaces of pinion and drive housings. Align gears and push new drive housing straight onto pinion housing and locating pins (A).
- 3 Install six screws (189). Torque evenly, referencing note 1 value in Fig. 3.
- 4 Install reed switch (182) with two screws (158).
- 5 Install bearing housings. Do steps 1 through 6 of **Bearing Housing and Connecting Rod** procedures on page 11.

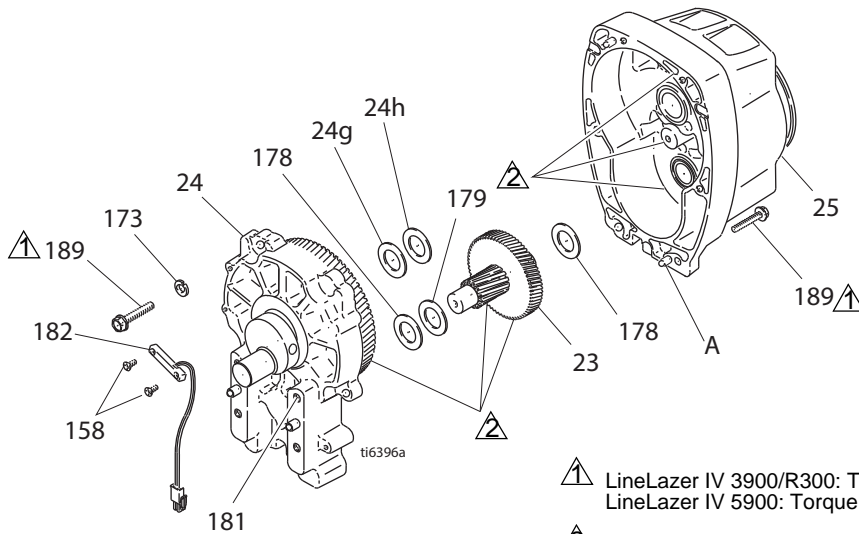

Fig. 3

▲ LineLazer IV 3900/R300: Torque to 200 in-lb (22.6 N·m)
 LineLazer IV 5900: Torque to 25 ft-lb (34 N·m)

▲ Apply remaining grease to these areas

Pinion Assembly/Clutch Armature/Clamp

Pinion Assembly Removal

If pinion assembly (25) is not removed from clutch housing (85), so 1 through (3). Otherwise, start at 4.

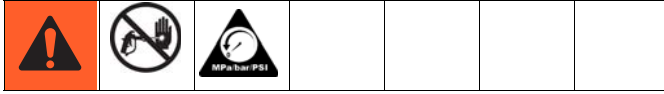

- 1 Remove drive housing, page. 12.
- 2 Fig. 12. Remove clip (251) and junction box (226).
- 3 Fig. 11. Disconnect pump stroke sensor and clutch cables.
- 4 Fig. 4. Remove four screws (189) and lock-washers (188) and pinion assembly (25).
- 5 Fig. 5. Place pinion assembly (25) on bench with rotor side up.

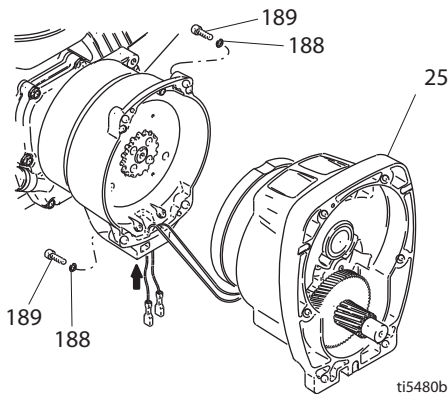

Fig. 4

- 6 Remove four screws (170) and lock-washers (172). Install two screws in threaded holes (E) in rotor. Alternately tighten screws until rotor comes off.

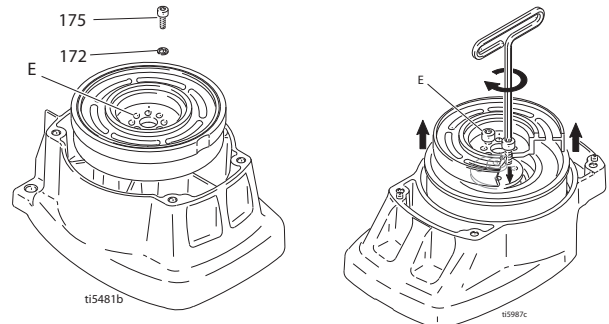

Fig. 5

- 7 Fig. 6. Remove retaining ring (25e).
- 8 Tap pinion shaft (25d) out with plastic mallet.

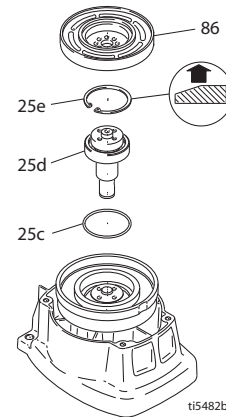

Fig. 6

Clutch Armature Removal

- 9 Fig. 7. Use an impact wrench to wedge between armature (87) and clutch housing to hold engine shaft during removal.
- 10 Remove four screws (175) and lock-washers (172).
- 11 Remove armature (87).

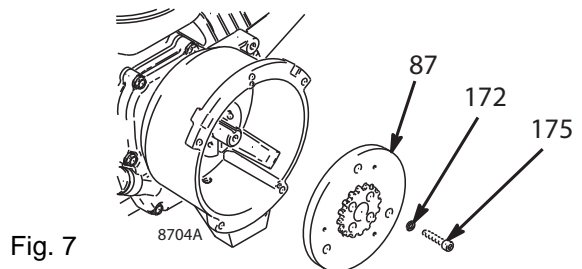

Fig. 7

Clutch Armature Installation

- 1 Fig. 8. Lay two stacks of two dimes on smooth bench surface.
- 2 Lay armature (87) on two stacks of dimes.
- 3 Press center of clutch down on bench surface.

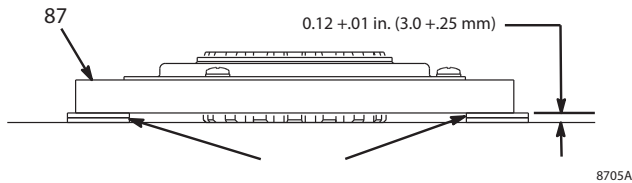
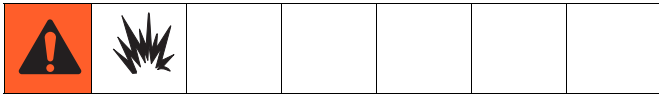

Fig. 8

- 4 Install armature (87) on engine drive shaft.
- 5 Install four screws (175) and lock-washers (172) with torque of 125 in-lb.

Clamp Removal

- 1 Perform Engine Removal.



- 2 Drain gasoline from tank according to Honda manual.
- 3 Tip engine on side to ensure gas tank is down and air cleaner is up.
- 4 Fig. 9. Loosen two screws (175) on clamp (82).
- 5 Push screwdriver into slot on clamp (82) and remove clamp.

Clamp Installation

- 1 Fig. 9. Install engine shaft key (88).
- 2 Tap clamp (82) on engine shaft (A) with plastic mallet. Maintain dimension shown on note 2 in Fig. 9.
- 3 Check dimensions: Place rigid, straight steel bar (B) across face of clutch housing (5). Use accurate measuring device to measure distance between bar and face of clamp. Adjust clamp as necessary. Torque two screws (175) to 125±10 in-lb (14 ± 1.1 N-m).

Pinion Assembly Installation

- 1 Fig. 6. Check o-ring (25c) and replace if missing or damaged.
- 2 Tap pinion shaft (25d) in with plastic mallet.
- 3 Install retaining ring (25e) with beveled side facing up.
- 4 Fig. 5. Place pinion assembly on bench with rotor side up.
- 5 Apply thread sealant to screws. Install four screws (170) and lock-washers (172). Alternately torque screws to 125 in-lb until rotor is secure. Use threaded holes to hold rotor.
- 6 Fig.4. Install pinion assembly (25) with five screws (189) and lock-washers (188).
- 7 Fig. 11. Connect pump stroke sensor and clutch cables.
- 8 Fig. 12. Install junction box (226) with clip (251).

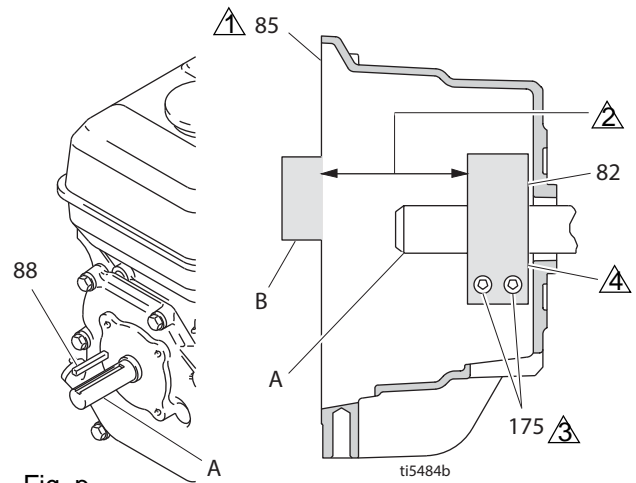

Fig. p

- ① Face of clutch housing
- ② 1.55 ± .010 in. (39.37 ± .25 mm); LineLazer IV 3900/R300
2.612 ± .010 in. (66.34 ± .25 mm); LineLazer IV 5900
- ③ Torque to 125 ± .10 in-lb (14 ± 1.1 N-m)
- ④ Chamfer this side

Clutch Housing

Removal

- 1 Fig. 10. Remove four cap screws (186) and lock washers (188) which hold clutch housing (85) to engine.
- 2 Remove screw (177) from under mounting plate (96).
- 3 Pull off clutch housing (85).

Installation

- 1 Fig. 10. Push on clutch housing (5).
- 2 Install four cap screws (186) and lock-washers (188) and secure clutch housing (85) to engine. Torque to 200 in-lb (22.6 N·m).

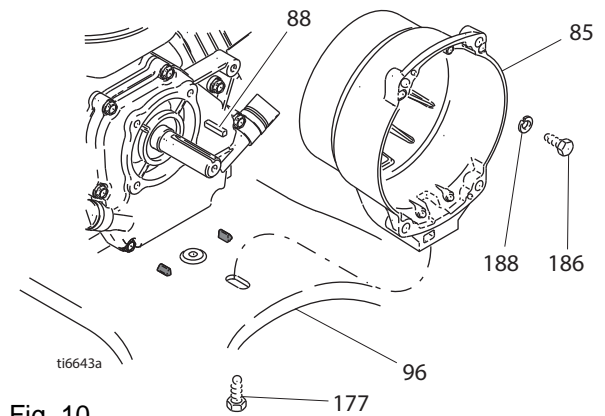

Fig. 10

Engine

Removal

NOTICE

All service to the engine must be performed by an authorized HONDA dealer.

- 1 Remove **Pinion Assembly/Clutch Armature/Clamp** and **Clutch Housing**. See pages 11-15.
- 2 Fig. 12. Remove clip (251) and junction box (226).
- 3 Fig. 11. Disconnect all necessary wiring.
- 4 Fig. 12. Remove screw (177). Remove two screws (117), lock nuts (118), and ground conductor (230, 260) from base of engine (185).
- 5 Lift engine carefully and place on work bench.

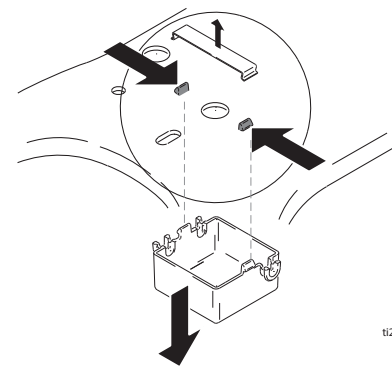
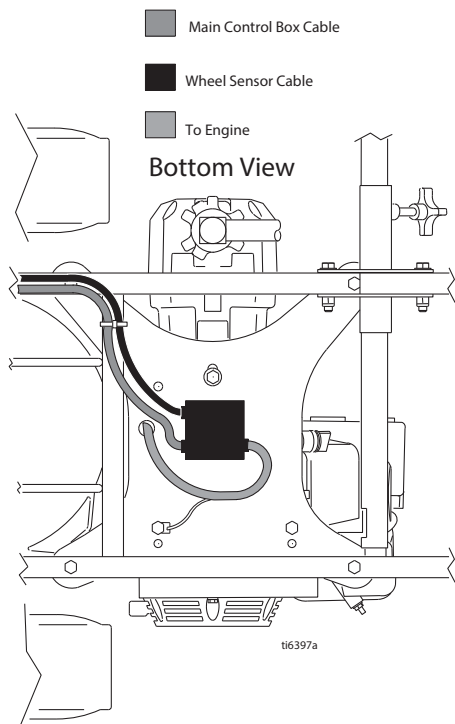
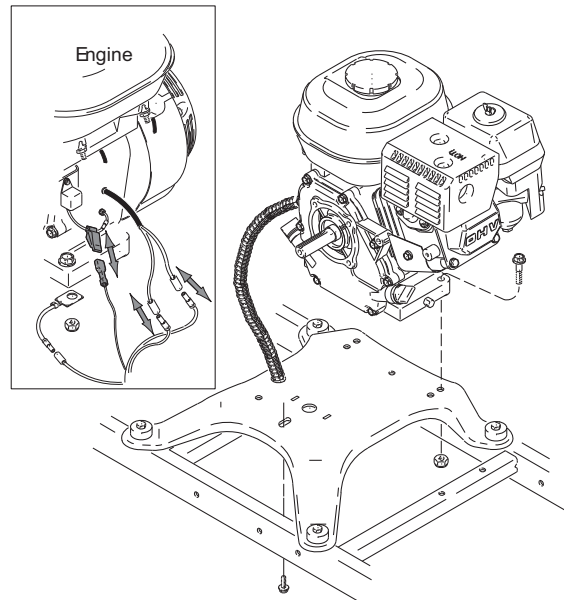

Fig. 12

t125625a

Installation

- 1 Lift engine carefully and place on cart.
- 2 Fig. 12. Install two screws (117) and ground conductor (223, 260) in base of engines and secure with lock nuts (118). Torque to 20 to 30 ft-lb.
- 3 Fig. 11. Connect all necessary wiring.
- 4 Install **Pinion Assembly/ Clutch Armature/Clamp** and **Clutch Housing**. See pages 11-15.

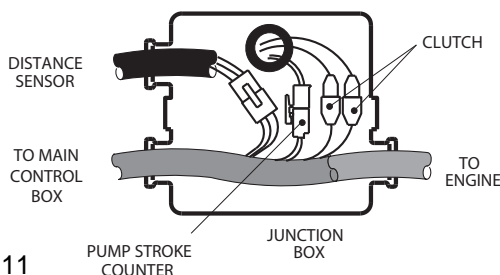

Fig. 11

Pressure Control

On/Off Switch

Removal



- 1 Relieve pressure, page 7.
- 2 Fig. 13. Remove two screws (125) and cover (31).
- 3 Pull display connector wings (A) open on PC board and pull display connector out.
- 4 Disconnect ON/OFF switch connector (B) from PC board.
- 5 Press in on two retaining tabs on each side of ON/OFF switch (15g) and remove switch.

Installation

- 1 Install ON/OFF switch (15g) so tabs of switch snap into place on inside of pressure control housing.
- 2 Connect ON/OFF switch connector (B) to PC board.
- 3 Push display connector into PC board close display connector wings (A) on PC board.
- 4 Install cover (31) with two screws (125).

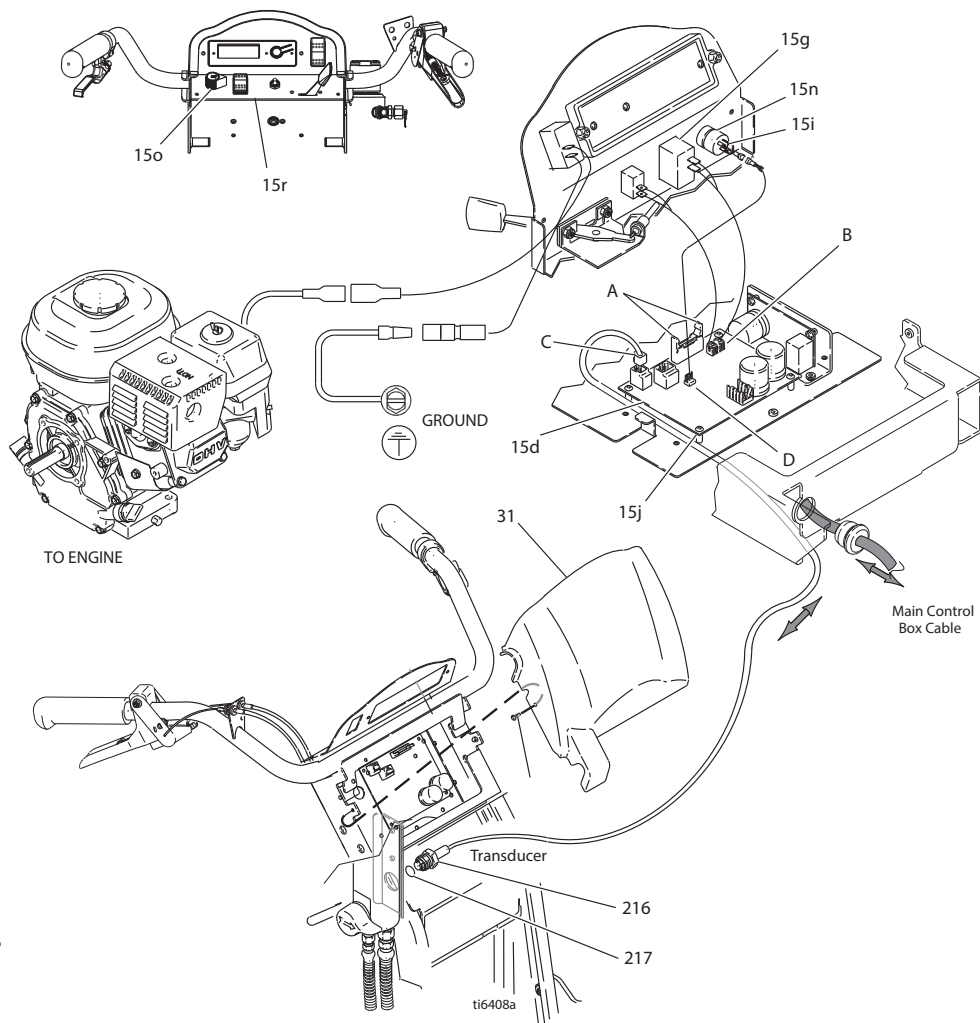

Fig. 13

Pressure Control

Control Board

Removal



- 1 Relieve pressure, page 7.
- 2 Fig. 13. Remove two screws (125) and control cover (31). Pull display connector wings open on PC board and pull display connector out.
- 3 Fig. 13 and 21. Note on a paper lead connections to the control board. Disconnect leads from control board (15d).
- 4 Fig. 13. Remove four screws (15j) from control board (15d).

Installation

- 1 Fig. 13. Install control board (15d) with four screws (15j).
- 2 Fig. 13 and 21. Refer to note on lead connections to the control board. Connect leads to control board (15d).
- 3 Fig. 13. Push display connector into PC board close display connector wings on PC board. Install control cover (31) with two screws (125).

Pressure Control Transducer

Removal

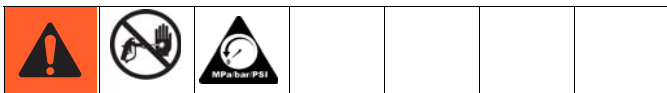

- 1 Relieve pressure, page 7.
- 2 Fig. 13. Remove two screws (125) and control cover (31).
- 3 Disconnect transducer lead (C) from control board (15d).
- 4 Remove pressure control transducer (216) and o-ring (217) from filter manifold (40).

Installation

- 1 Fig. 13. Install o-ring (217) and pressure control transducer (216) in filter manifold (40). Torque to 35-45 ft-lb.
- 2 Connect transducer lead (C) to control board (15d).
- 3 Install control cover (31) with two screws (125).

Pressure Adjust Potentiometer

Removal

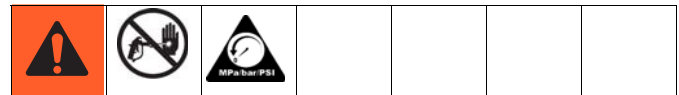

- 1 Relieve pressure, page 7.
- 2 Fig. 13. Remove two screws (125) and control cover (31).
- 3 Disconnect lead (D) from control board (15d).
- 4 Loosen set screws on potentiometer knob (15o) and remove knob, shaft nut, lock-washer and pressure adjust potentiometer (15i).
- 5 Remove seal (15n) from potentiometer (15i).

Installation

- 1 Install seal (15n) on potentiometer (15i).
- 2 Fig. 13. Install pressure adjust potentiometer (15i), shaft nut, lock-washer and potentiometer knob (15o).
 - a. Turn potentiometer shaft (15i) clockwise to internal stop. Assemble potentiometer knob (15o) to strike pin on plate (15r).
 - b. After adjustment of step a, tighten both set screws in knob 1/4 to 3/8 turn after contact with shaft.
- 3 Connect lead (D) to control board (15d).
- 4 Install control cover (31) with two screws (125).

Trigger Sensor Adjustment

Refer to **Troubleshooting** for trigger sensor adjustment, and see **Operation manual**.

Distance Sensor Adjustment

Gear Alignment

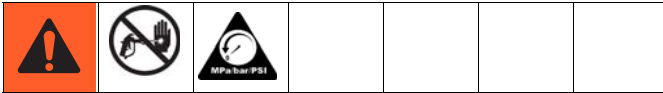

1. Relieve pressure, page 7.
2. Fig. 14. Remove dust cap (142) from wheel. Remove nut (127).
3. Remove wheel (120) from LineLazer.
4. Align gear (67) with sensor.
 - a. Pull gear out from wheel with gear puller.
 - b. Push gear in toward wheel with mallet.

5. Install wheel (120) on LineLazer.
6. Install nut (127) until tight, then back off 1/4 turn. Install dust cap (142) on wheel.

Sensor Height Adjustment

1. Remove wheel (120) from LineLazer.
2. Remove distance sensor (66).
3. Adjust sensor assembly height with two 17 mm nuts of sensor so bottom surface of sensor is 0.638 +/- 0.020 from bottom surface of shield. Torque to 8 +/- 2 in-lb.
4. Reassemble distance sensor (66) and wheel (82).

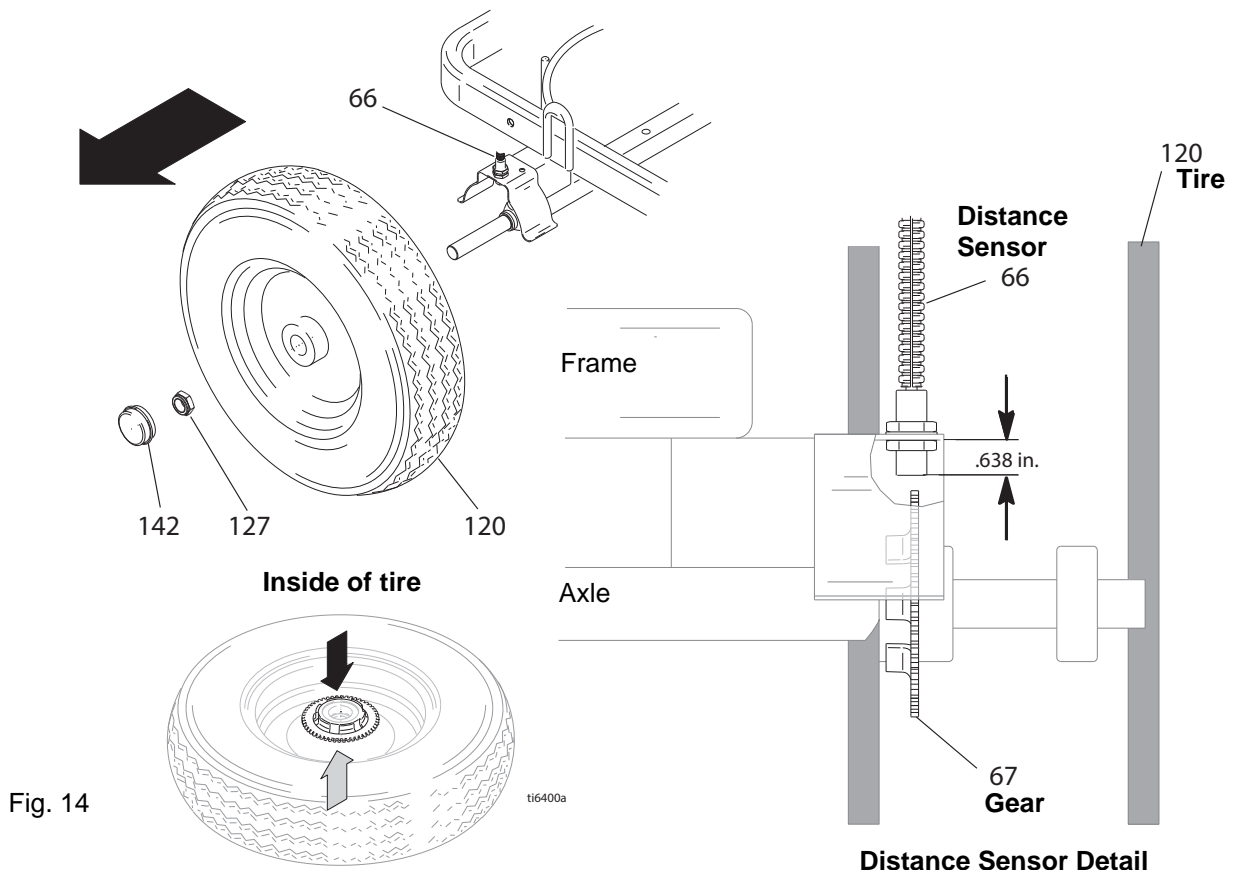

Control Board Diagnostics

Digital Display Messages



Relieve pressure before repair; page 7. No display does not mean that sprayer is not pressurized.

DISPLAY	SPRAYER OPERATION	INDICATION	ACTION
No Display	Sprayer may be pressurized	Loss of power or display not connected	Check power source. Relieve pressure before repair or disassembly. Verify display is connected.
----	Sprayer may be pressurized	Pressure less than 200 psi (14 bar, 1.4 MPa)	Increase pressure as needed.
3000 psi 210 bar 21 MPa	Sprayer is pressurized. Power is applied. (Pressure varies with tip size and pressure control setting).	Normal operation	Spray
E:02	Sprayer stops. Engine is running.	Exceeded pressure limit	Remove any filter clogs or flow obstructions. Make sure gun triggering is locked open if using Auto-Clean valve.
E:03	Sprayer stops. Engine is running.	Pressure transducer faulty, bad connection or broken wire.	Check transducer connections and wire. Replace transducer or control board, if necessary.
E:05	Sprayer stops. Engine is running.	High clutch current	<ol style="list-style-type: none"> 1. Check clutch 7-pin bulkhead connector. Clean contacts. 2. Measure $1.2 \pm 0.2\Omega$ (LineLazer IV 3900/R300); $1.7 \pm 0.2\Omega$ (LineLazer IV 5900) across clutch field at 70°F. 3. Replace clutch field assembly

After a fault, follow these steps to restart sprayer:

1. Correct fault condition
2. Turn sprayer OFF
3. Turn sprayer ON

Displacement Pump

Removal

1. Flush pump.

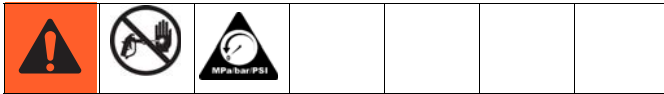

2. Relieve pressure, page 7.
3. Fig. 15. Cycle pump piston rod (A) to lowest position.
4. Fig. 15. Remove suction tube (34) and hose (100).

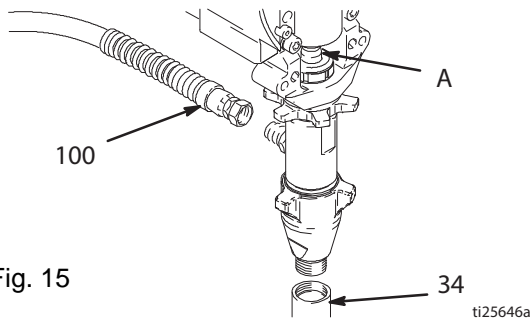

Fig. 15

5. Fig. 16. Use screwdriver: push retaining spring up and push out pin (235).

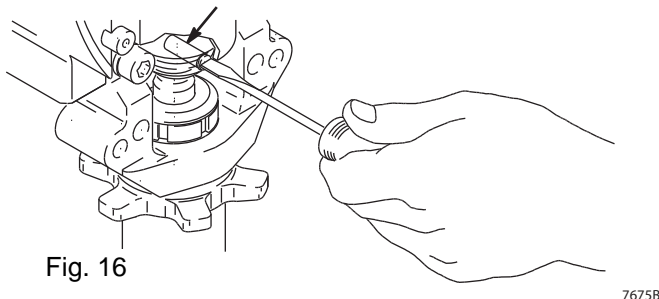

Fig. 16

6. Fig. 17. Loosen locknut by hitting firmly with a 20 oz (maximum) hammer. Unscrew pump.

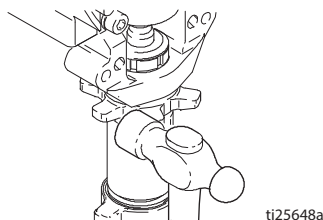

Fig. 17

Repair

See manual 310643 for pump repair instructions.

Installation

NOTICE

If pin works loose, parts could break off due to force of pumping action. Parts could project through the air and result in serious injury or property damage. Make sure pin and retaining spring are properly installed.

NOTICE

If the pump locknut loosens during operation, the threads of the bearing housing will be damaged. Make sure locknut is properly tightened.

1. Fig. 18. Pull piston rod out 1.5 in. Screw in pump until holes in bearing cross link and piston rod align.

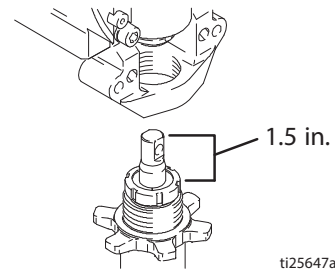

Fig. 18

2. Fig. 16. Push pin (235) into hole. Push retaining spring into groove around connecting rod.

Fig. 19. Screw jam nut down onto pump until nut stops. Screw pump up into bearing housing until it is stopped by jam nut. Back off pump and jam nut to align pump outlet to back. Tighten jam nut by hand, then tap 1/8 to 1/4 turn with a 20 oz (maximum) hammer to approximately 75± 5 ft-lb (102 N•m).

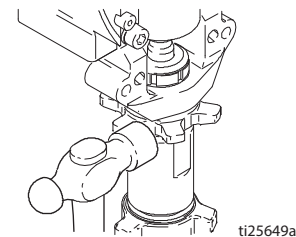

Fig. 19

Fig. 20. Fill packing nut with Graco TSL unit fluid flows onto the top of seal.

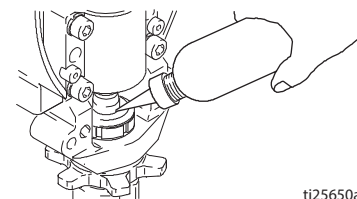
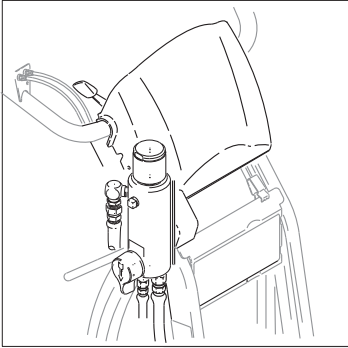

Fig. 20

Parts - LineLazer IV

Parts Page 32



Parts Page 26

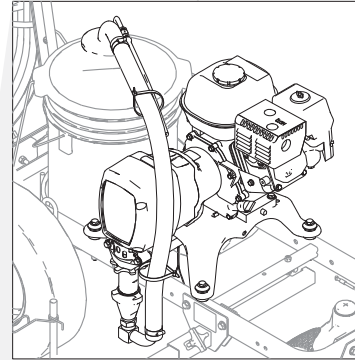

Parts Page 30

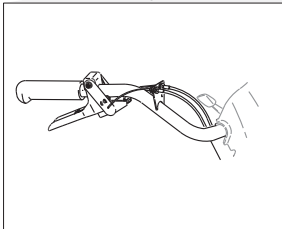

Parts Page 28

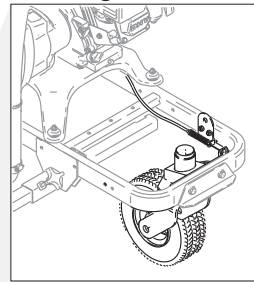

Parts Page 24

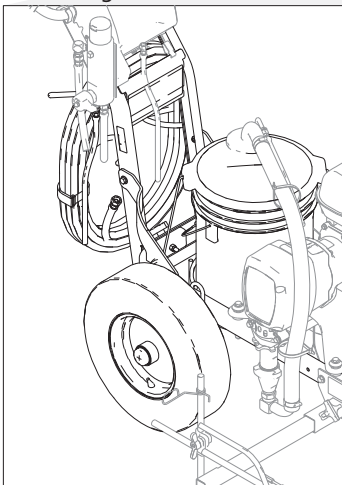

Parts Page 30

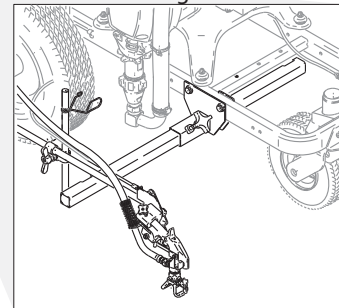

Sheet 1 of 7

t125626a

Parts - Drive and Pinion Housing Assemblies

Ref No. 24 and 25

Ref No. 24: Drive Housing Assembly 287467 for LineLazer IV 3900/R300; Drive Housing Assembly 287469 for LineLazer IV 5900

Ref No. 25: Pinion Housing Assembly 287463 for LineLazer IV 3900/R300; Pinion Housing Assembly 287465 for LineLazer IV 5900

Ref.	Part	Description	Qty.	Ref.	Part	Description	Qty.
24	287467	HOUSING, drive (3900/R300)	1	25	287463	HOUSING, pinion (3900/R300)	1
	287469	HOUSING, drive (5900)	1		287465	HOUSING, pinion (5900)	1
24g		WASHER		25a		KIT, repair, coil	
	107089	(3900/R300)	1		287474	(3900/R300)	1
	194173	(5900)	1		287476	(5900)	1
24h		WASHER		25b	105489	PIN	2
	116191	(3900/R300)	1	25d*		PINION SHAFT	
	116192	(5900)	1		241110	(3900/R300)	1
					241114	(5900)	1
				25e		RETAINING RING, large	
					113094	(3900/R300)	1
					112770	(5900)	1
				158	114528	SCREW, machine	2
				181	116618	MAGNET	1
				182	119562	SWITCH, reed w/ connector	1

* Must be ordered separately

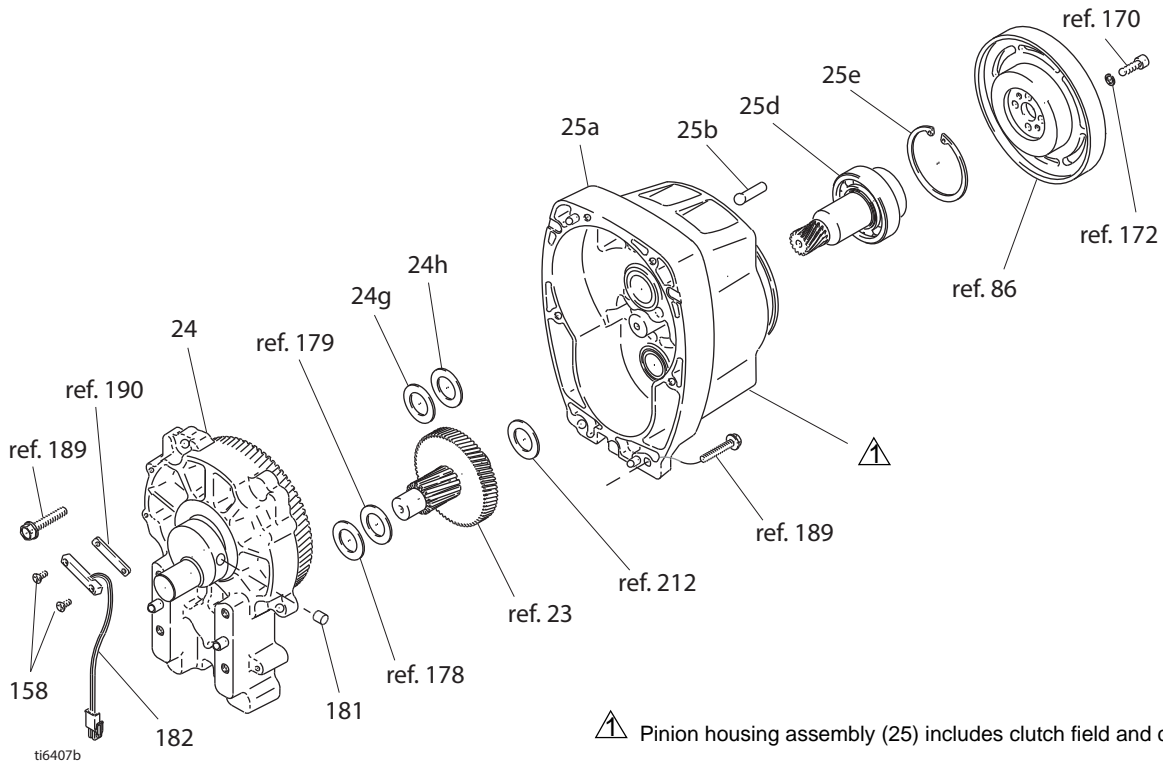

⚠ Pinion housing assembly (25) includes clutch field and connector

Parts Drawing - LineLazer IV

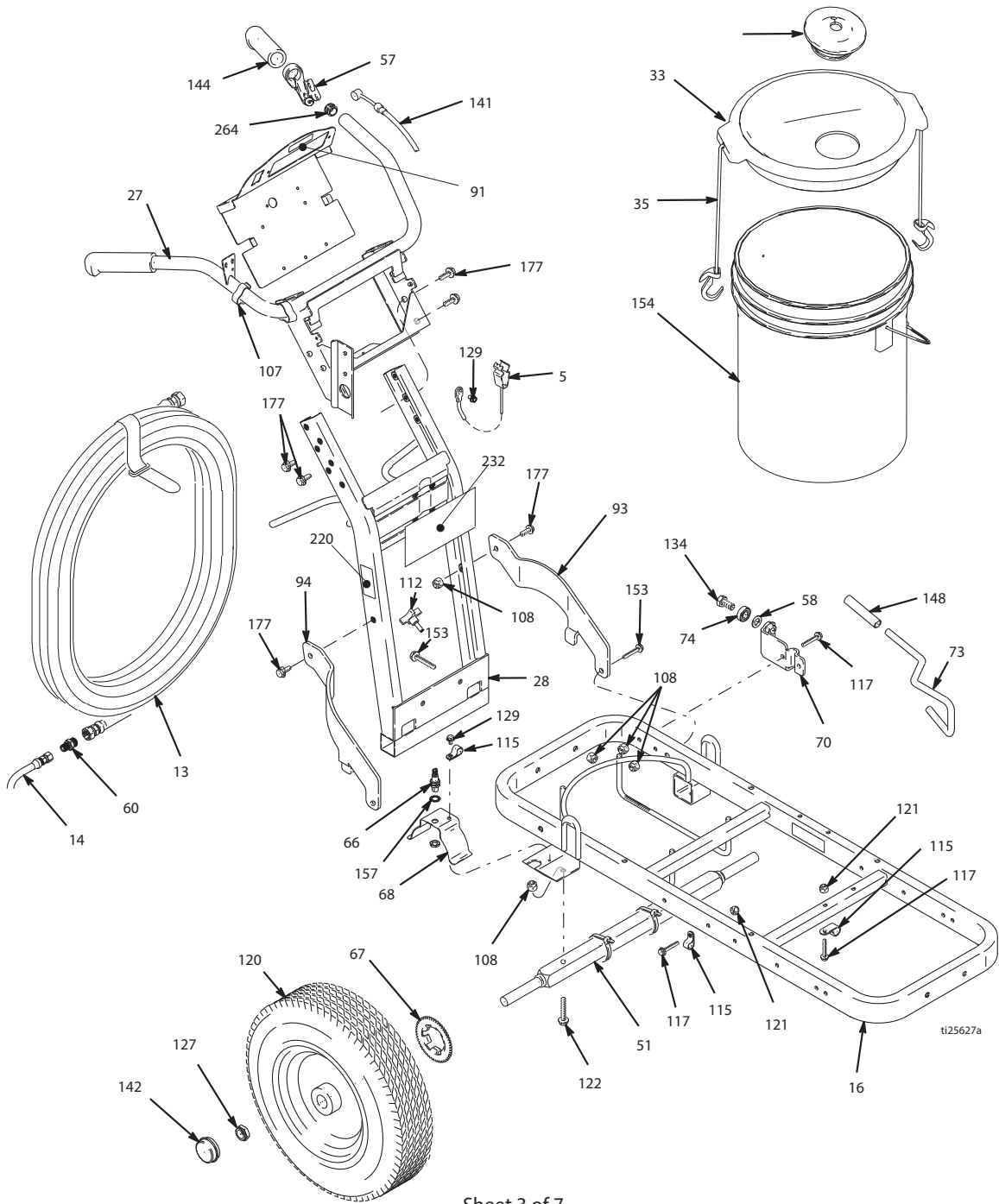

Sheet 3 of 7

Parts List - LineLazer IV

Ref.	Part	Description	Qty.
5	237686	WIRE, ground assembly w/ clamp	1
13	245225	HOSE, 3/8 in. x 50 ft	1
14	245798	HOSE, 1/4 in. x 7 ft	2
16	287623	FRAME, linestriper (painted)	1
27	287417	HANDLE	1
28	287622	SUPPORT, handle (painted)	1
33	24U241	COVER, pail (includes 35)	1
35	119771	STRAP, cover	2
42	108471	KNOB, pronged	1
51	193405	AXLE	1
57	194310	LEVER, actuator	1
58	195134	SPACER, ball, guide	1
60	196176	ADAPTER, nipple	1
66	287698	KIT, sensor, distance (includes 68, 115, 129, 157)	1
67		GEAR, signal	1
68	198612	SHIELD, sensor, distance	1
70	198891	BRACKET, mounting	1
73	198930	ROD, brake	1
74	198931	BEARING	1
93	15F577	BRACE, left (painted)	1
94	15F576	BRACE, right (painted)	1
107	178342	CLIP	2
108	101566	NUT, lock	8
115	108868	CLAMP, wire	3
117	110837	SCREW, flange, hex	3
120	255162	WHEEL, pneumatic (includes 67)	2
	249082	WHEEL, turf (models 24M605, 24M607)	2
121	111040	NUT, lock, insert, nylock, 5/16	3
122	111194	SCREW, cap flang hd	2
127	112405	NUT, lock	2
129	112798	SCREW, thread forming, hex hd	2
134	113961	SCREW, cap, hex hd	1
141	241445	CABLE, caster	1
142	114648	CAP, dust	2
144	114659	GRIP, handle	2
148	114808	CAP, vinyl	1
153	114982	SCREW, cap, flng hd	4
154	115077	PAIL, plastic	1
157	116287	WASHER, sst, external	1
158	114528	SCREW, mach, phillips, pnhd	2
177	112395	SCREW, cap, flnghd	6
181	116618	MAGNET	1
182	119562	SWITCH, reed, w/ connector	1
220▲	15F638	LABEL, GMAX warning fires & skin	1
232	15F545	LABEL, brand, handle	1
	16N543	LABEL, brand, handle (models 24M605, 24M607)	1
264	120151	PLUG, tube	2
265	241104	HOPPER, 15 gal (models 24M605)	1

▲ Replacement Danger and Warning labels, tags, and cards are available at no cost.

Parts Drawing - Line Lazer IV

Models 248862, 248866

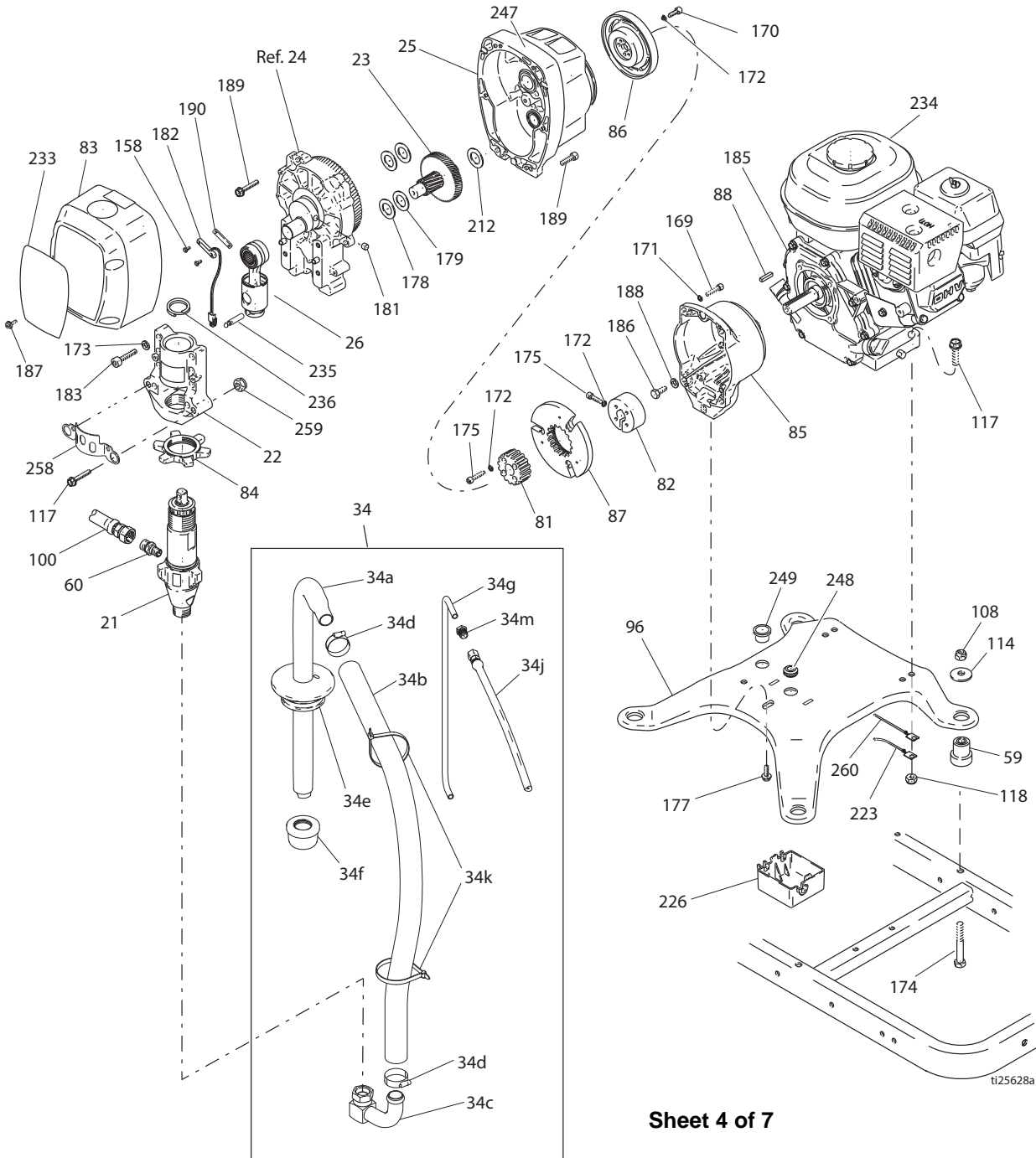

Sheet 4 of 7

Parts List - LineLazer IV

Models 248862, 248866

Ref.	Part	Description	Qty.	Ref.	Part	Description	Qty.
				183	113467	SCREW, cap, soc hd (3900/R300)	4
					114666	SCREW, cap, sock hd (5900)	4
21	277069	PUMP, displacement (3900/R300)	1	185	108879	ENGINE, gas, 4.0 hp (3900/R300)	1
	277070	PUMP, displacement (5900)	1		114530	ENGINE, gas 5.5 hp (5900)	1
22	287714	HOUSING, bearing (3900/R300)	1	186	108842	SCREW, cap, hex hd	4
	287715	HOUSING, bearing (5900)	1	187	118444	SCREW, machine hex washer hd	4
23	287653	GEAR, combination (3900/R300)	1	188	100214	WASHER, lock	4
	287460	GEAR, combination (5900)	1	189	119426	SCREW, mach, hex washr hd (3900/R300)	8
26†	287719	ROD, connecting (3900/R300)	1		15C753	Screw, mach, hex washr hr (5900)	6
	287720	ROD, connecting (5900)	1	190	15F947	SHIELD, magnetic	1
34	24V567	HOSE ASSEMBLY, drain (items 34a thru 34n)	1	212	15F250	WASHER, thrust (3900/R300)	1
34a	15F149	TUBE, suction	1		114672	WASHER, thrust (5900)	1
34b	185381	HOSE	1	223	119579	CONDUCTOR, ground (3900/R300)	1
34c	110194	SWIVEL, 180°	1		240997	CONDUCTOR, ground (5900)	1
34d	101818	CLAMP, hose	1	226	287695	BOX	1
34e	278722	GASKET, pail	1	233	15F546	LABEL, brand (3900/R300)	1
34f	181072	STRAINER	1		15F547	LABEL, brand (5900)	1
34g	16X071	TUBE, drain (includes diffuser)	1		16N452	LABEL, brand (R300) (models 24M605, 34M607)	1
34j	245798	HOSE, coupled, 1/4 in. x 7 ft	1	234▲	194126	LABEL, warning	1
34k	114958	STRAP, tie	2	235		PIN, pump (3900)	1
34m	196180	BUSHING	1		15F855	(5900)	1
34n▲	195119	LABEL, warning	1		15F856	(5900)	1
59	119695	DAMPEBER, engine mount	4	236‡	119676	SPRING, retaining (3900/R300)	1
60	196176	ADAPTER, nipple	1		119778	SPRING, retaining (5900)	1
81†		HUB, armature	1	247	290228	LABEL, caution	1
82	193680	COLLAR, shaft	1	248	114629	GROMMET	1
83	287521	COVER, front (3900/R300)	1	249	119569	BUSHING	1
	287511	COVER, front (5900)	1	258	15C762	SHIELD, pump rod	1
84	192723	NUT, retaining (3900/R300)	1	259	110996	NUT, hex	2
	193031	NUT, retaining (5900)	1	260	240997	CONDUCTOR, ground (5900)	1
85	15E535	HOUSING, clutch (3900/R300)	1				
	15E277	HOUSING, clutch (5900)	1				
86†		ROTOR, clutch, 4 in. (3900/R300)	1				
		ROTOR, clutch, 5 in. (5900)	1				
87†		ARMATURE, clutch, 4 in. (3900/R300)	1				
		ARMATURE, clutch, 5 in. (5900)	1				
88	183401	KEY, parallel	1				
96	15F583	PLATE, engine mount	1				
100	245797	HOSE, 3/8 in. x 3.0 ft	1				
108	101566	NUT, lock	2				
114	108851	WASHER, plain	8				
117	110837	SCREW, flange, hex	2				
118	110838	NUT, lock	2				
169	119426	SCREW, hex washr hd (3900/R300)	4				
	102962	SCREW, cap sch (5900)	4				
170†	101682	SCREW, cap sch	4				
171	104008	WASHER, lock, spring (5900)	4				
172†	105510	WASHER, lock, spr (hi-collar)	10				
173		WASHER, lock spr (hi-collar) (3900/R300)	4				
		(5900)	4				
174	113743	SCREW, cap, hex hd	4				
175†	108803	SCREW, hex, socket head	6				
177	112395	SCREW, cap, flnghd	1				
178	114672	WASHER, thrust	1				
179	114699	WASHER, thrust	1				

▲ Replacement Danger and Warning labels, tags, and cards are available at no cost.

† Parts included in Clutch Repair Kits 241109 (3900/R300) and 341113 (5900) (purchase separately).

‡ Parts included in Connecting Rod Kits (purchase separately).

Parts Drawing - LineLazer IV

Models 248862, 248866

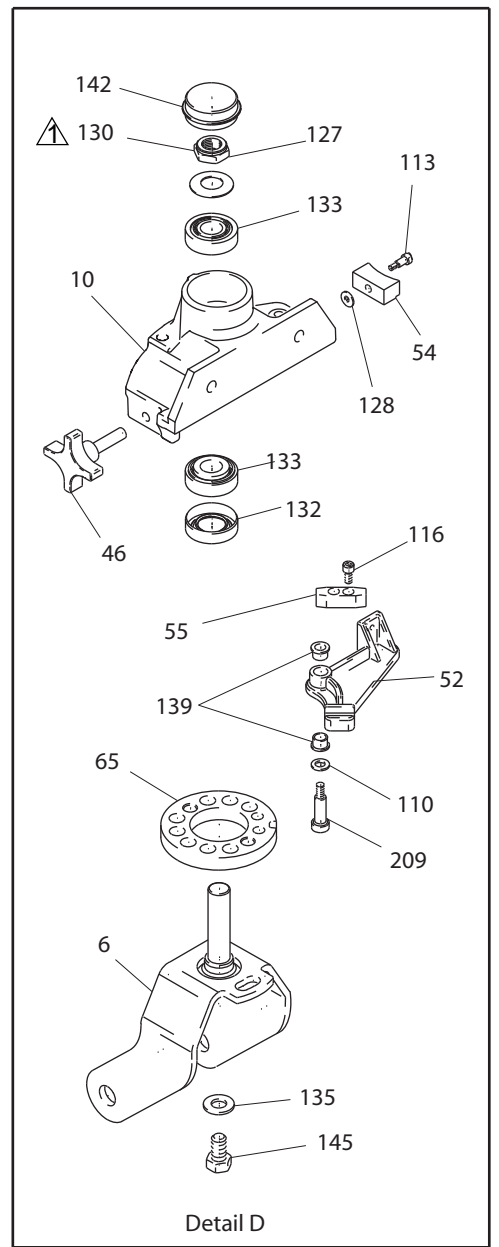
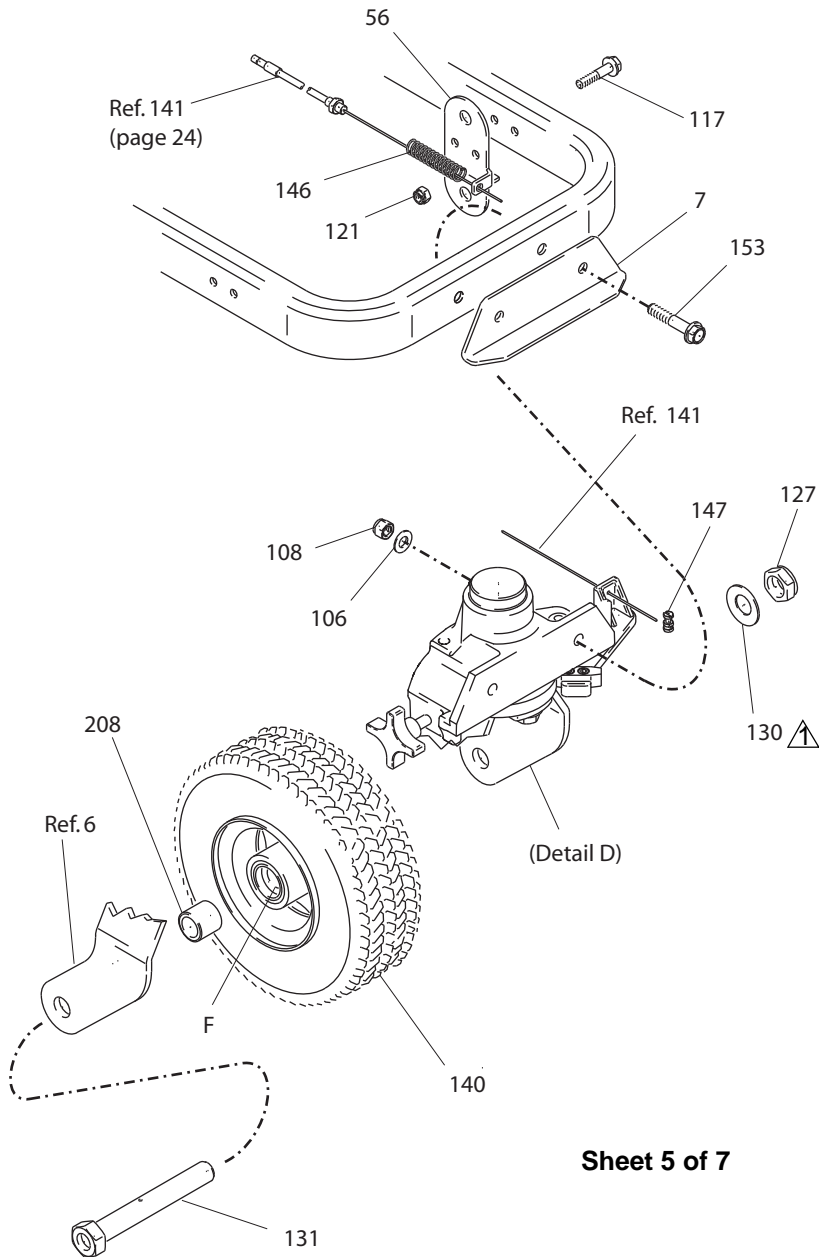

Sheet 5 of 7

▲ Install washers (130) concave surface to inside.

ti6404b

Parts List - LineLazer IV

Models 248862, 248866

Ref.	Part	Description	Qty.
6	240942	SHAFT, fork	1
7	240991	BRACKET, caster, front	1
10*	15G952	BRACKET	
46	181818	KNOB, pronged	1
52	193528	ARM, detent	1
54	193661	JAW	1
55	193662	STOP, wedge	1
56	15F910	BRACKET, cable	1
65	198606	DISK, adjuster	1
106	100731	WASHER	2
108	101566	NUT, lock	2
110	15J603	WASHER, plain	1
113	108483	SCREW, shoulder, sch	2
116	110754	SCREW, cap, sch	2
117	110837	SCREW, flange, hex	2
121	111040	NUT, lock, insert, nylock, 5/16	2
127	112405	NUT, lock	2
128	112776	WASHER, plain	1
130	112825	SPRING, belleville	3
131	113471	SCREW, cap, hex hd	1
132*	113484	SEAL, grease	1
133*	113485	BEARING, cup/cone	2
135	113962	WASHER, hardened, SAE	1
139	114548	BEARING, bronze	2
140	114549	WHEEL, pneumatic	1
142	114648	CAP, dust	1
145	114681	SCREW, cap, hex hd	1
146	114682	SPRING, compression	1
147	114802	STOP, wire	1
153	114982	SCREW, cap, flng hd	2
208	193658	SPACER, seal	2
209*	120476	BOLT	1

* *Parts included in Bracket Repair Kit 240940 (purchase separately).*

Parts Drawing - LineLazer IV

Models 248862, 248866

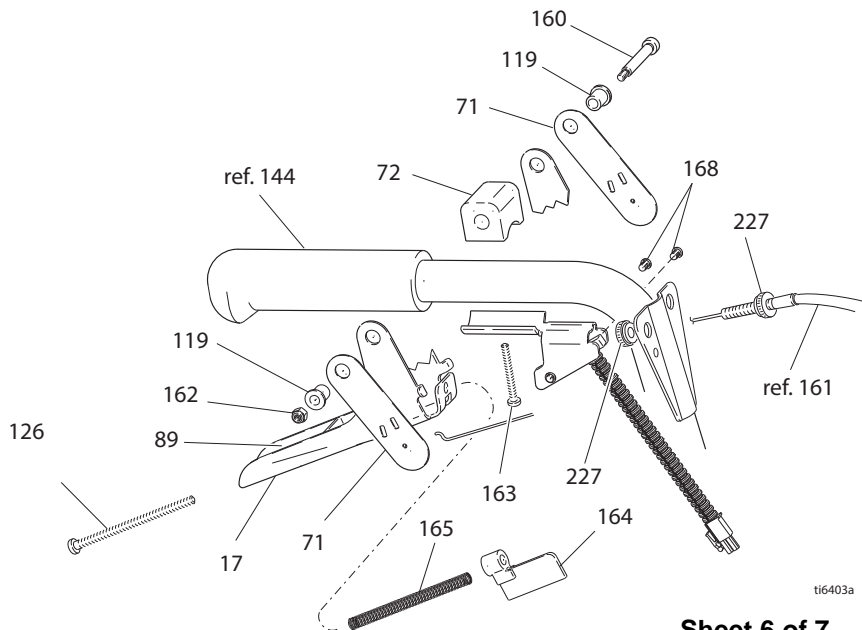
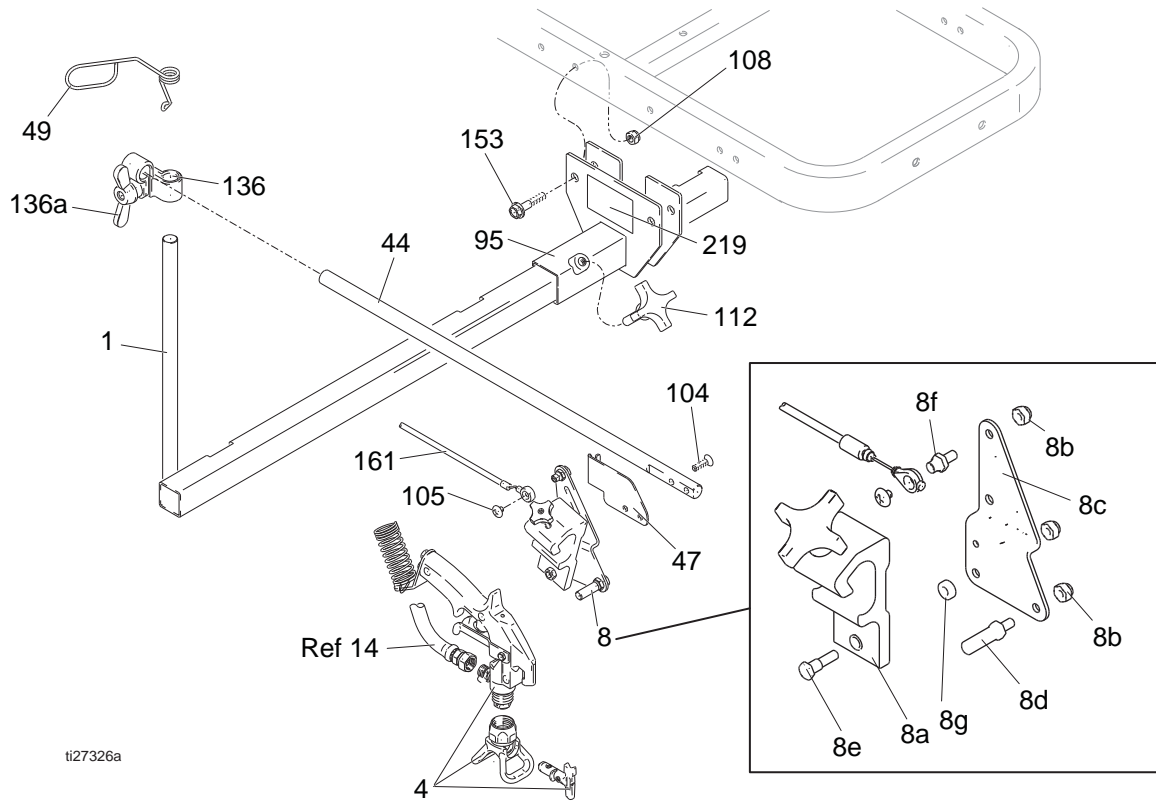

Sheet 6 of 7

Parts List - LineLazer IV

Models 248862, 248866

Ref.	Part	Description	Qty.
1	224052	BRACKET, support gun	1
4	248157	GUN, flex, basic, includes guard & tip	1
8	287570	HOLDER ASSEMBLY, gun (items 8a thru 8f)	1
8a	287569	HOLDER, gun	1
8b	102040	NUT, lock	4
8c	15F214	LEVER, actuator	1
8d	15F209	STUD, pull, trigger	1
8e	24Y991	KIT, pivot	1
8f	15F211	STUD, cable	1
8g	24Y991	KIT, pivot	1
17*	245733	KIT, trigger handle repair (includes 17, 89, 126, 164, 165)	1
44	15F212	ARM, holder, gun	1
47	15F213	BRACKET, cable	1
49	188135	GUIDE, cable	1
71	198895	PLATE, lever, pivot	2
72	198896	BLOCK, mounting (mach)	1
89*	15A644	LABEL, trigger	1
95	15F389	BRACKET, gun arm	1
104	119647	SCREW, cap, socket, flthd	2
105	119648	SCREW, mach, trusshd	1
108	101566	NUT, lock	2
112	111145	KNOB, pronged	1
119	111017	BEARING, flange	2
126*	112381	SCREW, mach, pan hd	1
136	287566	KIT, clamp (includes 136a)	1
136a	114028	NUT, wing	1
153	114982	SCREW, cap, flng hd	1
160	116941	SCREW, shoulder, socket head	1
161	287696	CABLE, gun (includes 227)	1
162	116969	NUT, lock	1
163	116973	SCREW, #10 taptite phil	1
164*	117268	BRACKET, interrupter	1
165*	117269	SPRING	1
166	287699	SENSOR, trigger	1
168	117317	SCREW, plastite, pan head	2
219▲	15F637	LABEL, GMAX warning skin inject	1
227	15F624	NUT, cable, gun (knurled)	2

▲ Replacement Danger and Warning labels, tags, and cards are available at no cost.

* Parts included in Trigger Kit 245733 (purchase separately).

Parts Drawing - LineLazer IV

Models 248862, 248866

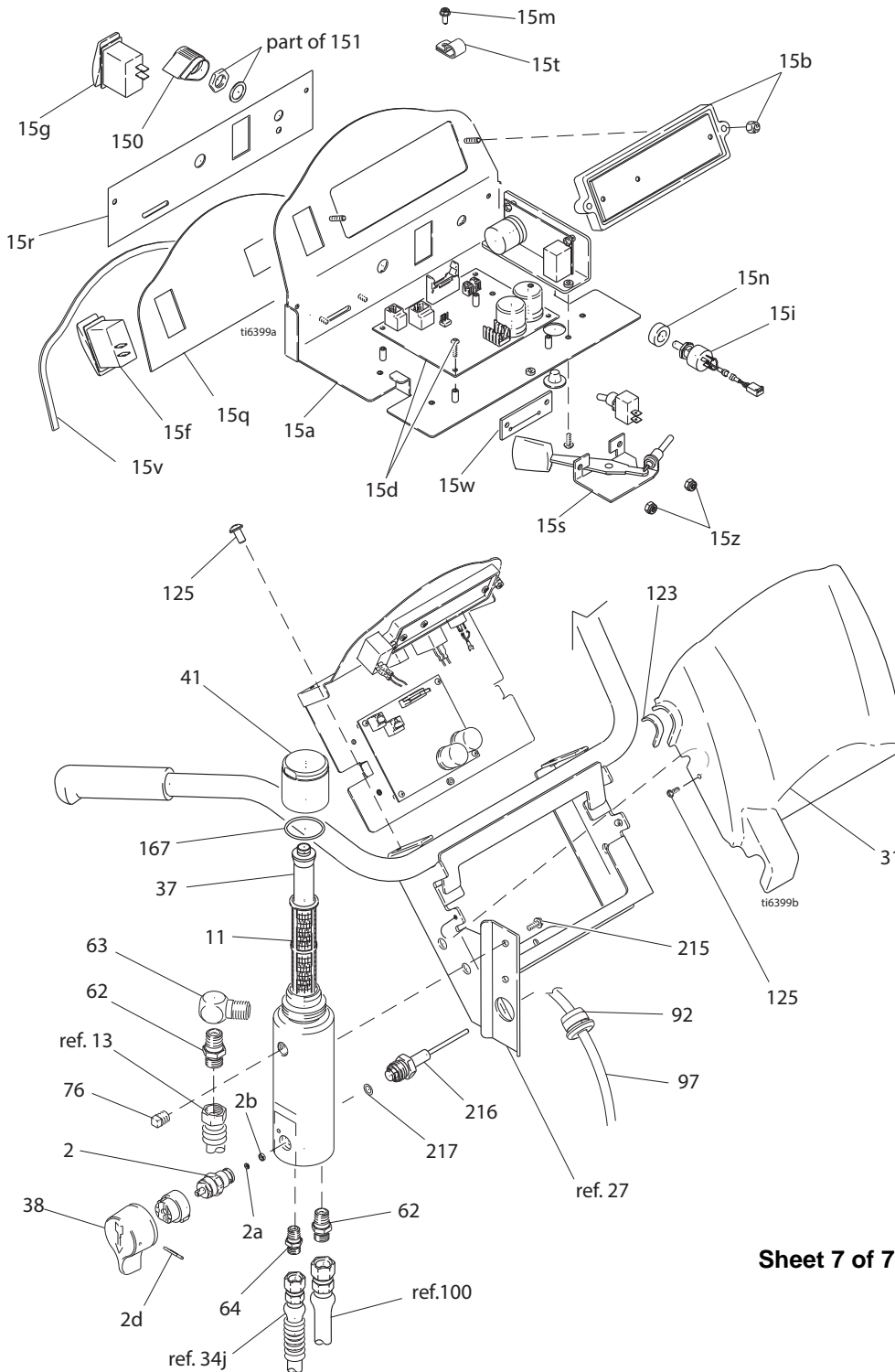

Sheet 7 of 7

Parts List - LineLazer IV

Models 248862, 248866

Ref.	Part	Description	Qty.
2*	245103	VALVE, drain (includes 2a, 2b, 2c, 2d, 38)	1
2a	193709	SEAT, valve	1
2b	193710	SEAL, valve	1
2c	116424	NUT, cap	1
2d	114708	SPRING	1
11*	244067	FILTER, fluid	1
15a	15F272	PLATE, control	1
15b	287688	KIT, display board	1
15d	287689	BOARD, control	1
15f	114954	SWITCH, rocker	1
15g	116752	SWITCH, rocker	1
15i	256219	POTENTIOMETER KIT	1
15m	116719	SCREW, 8-32, hx hd	3
15n	198650	SPACER, shaft	1
15o	116167	KNOB, potentiometer	1
15q	15F543	LABEL, control, top	1
15r	15F544	LABEL, control, bottom	1
15s	287692	KIT, control, throttle	1
15t	119736	CLAMP, cable	1
15v	15F777	GASKET, control	1
15V	15F776	GASKET, throttle	1
15z	109466	NUT, lock, hex	2
31	15F589	COVER, control	1
37*	15C766	TUBE, diffusion	1
38*	15G563	HANDLE	1
40*	15H561	MANIFOLD, filter, 3/8 npt	1
41*	287285	KIT, repair, filter cap (includes 37, 167)	1
62*	196178	ADPATER, nipple	2
63*	196179	FITTING, elbow, street	1
64	196181	FITTING, nipple	1
76	15G331	PLUG, pipe	1
92	111348	BUSHING, relief, strain	1
97	15E910	WIRE, harness	1
123	15F814	GASKET	2
125	116719	SCREW, 8-32, hex hd	5
167*	117285	PACKING, o-ring	1
215	111801	SCREW, cap, hex hd	2
216*	287172	TRANSDUCER, pressure control	1
217*	111457	PACKING, o-ring	1

* Parts included in Kit 288100 (purchase separately).

Pressure Control Wiring Diagram

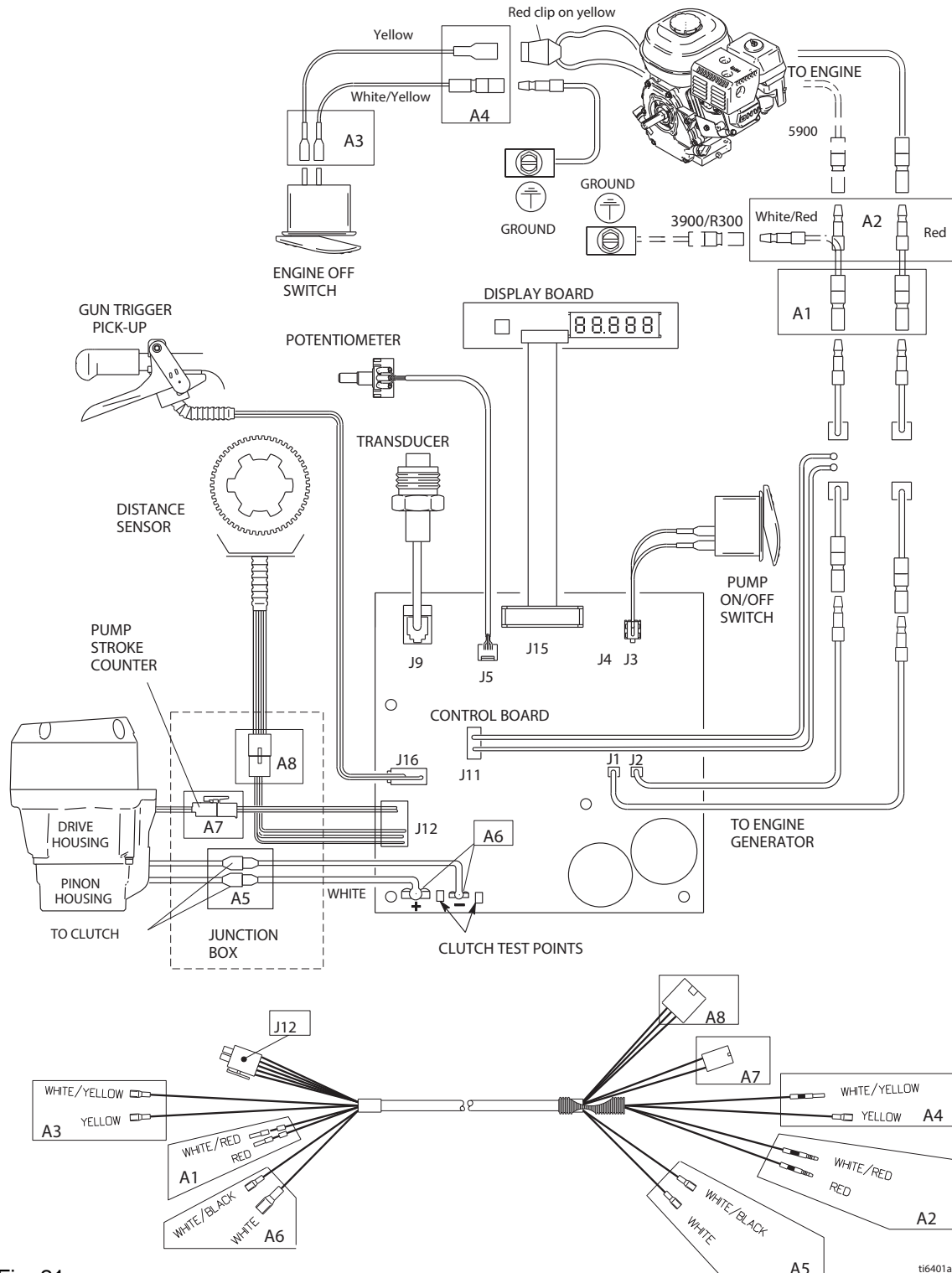

Fig. 21

ti6401a

Technical Data

LineLazer IV 3900, R300, 5900, and FieldLazer R300 Airless Line Stripers		
Honda GX120 Engine		
Power Rating @3600 rpm		
ANSI	4.0 Horsepower	
DIN 6270B/DIN 6271	NA.....2.1 Kw - 2.8 Ps	NB.....2.6 Kw - 3.6 Ps
Maximum working pressure	3300 psi	(228 bar, 22.8 MPa)
Noise Level		
Sound power	105 dBa per ISO 3744	
Sound pressure	96 dBa measured at 3.1 feet (1 m)	
Vibration Level*		
LineLazer IV 3900/R300	Left hand.....1.81 m/sec ²	Right hand.....1.45 m/sec ²
LineLazer IV 5900	Left hand.....2.05 m/sec ²	Right hand.....1.70 m/sec ²
* Vibration measured per ISO 5349 based on 8 hour daily exposure		
	US	Metric
Maximum Delivery		
LineLazer IV 3900/R300	1.15 gpm	4.4 liter/min
LineLazer IV 5900	1.5 gpm	5.7 liter/min
Maximum tip size		
LineLazer IV 3900/R300	1 gun with 0.034 in. tip	2 guns with 0.024 in. tip
LineLazer IV 5900	1 gun with 0.041 in. tip	2 guns with 0.028 in. tip
Inlet paint strainer		
16 mesh (1190 micron) stainless steel screen reusable		
Outlet paint filter		
60 mesh (250 micron) stainless steel screen, reusable		
Pump inlet size		
3/4 in. npt (m)		
Fluid outlet size		
1/4 npsm from fluid filter		

Wetted parts.....nickel-plated carbon steel, PTFE,
 Nylon, polyurethane, UHMW polyethylene,
 fluoroelastomer, acetal, leather, tungsten carbide,
 stainless steel, chrome plating

Dimensions

LineLazer IV 3900/R300		
Model 248862, 249008, 24M605, 24M607 Striper		
Weight (dry, without packaging)	212 lb.	96 kg
Height	40 in.	101.6 cm
Length	65 in.	165.1 cm
Width	32 in.	81.3 cm
Model 248863, 249009 Striper with 2nd Gun Kit		
Weight (dry, without packaging)	222 lb.	101 kg
Height	40 in.	101.6 cm
Length	65 in.	165.1 cm
Width	32 in.	81.3 cm
Model 248864 Striper with Bead		
Weight (dry, without packaging)	212 lb.	96 kg
Height	40 in.	101.6 cm
Length	65 in.	165.1 cm
Width	32 in.	81.3 cm
Model 248865 Striper 2nd Gun Kit with Bead		
Weight (dry, without packaging)	222 lb.	101 kg
Height	40 in.	101.6 cm
Length	65 in.	165.1 cm
Width	32 in.	81.3 cm
LineLazer IV 3900/R300		
Model 248866, 249010 Striper		
Weight (dry, without packaging)	232 lb.	105 kg
Height	40 in.	101.6 cm
Length	65 in.	165.1 cm
Width	32 in.	81.3 cm
Model 248867, 249011 Striper with 2nd Gun Kit		
Weight (dry, without packaging)	242 lb.	110 kg
Height	40 in.	101.6 cm
Length	65 in.	165.1 cm
Width	32 in.	81.3 cm
Model 248868 Striper with Bead		
Weight (dry, without packaging)	232 lb.	105 kg
Height	40 in.	101.6
Length	65 in.	165.1 cm
Width	32 in.	81.3 cm
Model 248869 Striper 2nd Gun Kit with Bead		
Weight (dry, without packaging)	242 lb.	110 kg
Height	40 in.	101.6 cm
Length	65 in.	165.1 cm
Width	32 in.	81.3 cm

Graco Standard Warranty

Graco warrants all equipment referenced in this document which is manufactured by Graco and bearing its name to be free from defects in material and workmanship on the date of sale to the original purchaser for use. With the exception of any special, extended, or limited warranty published by Graco, Graco will, for a period of twelve months from the date of sale, repair or replace any part of the equipment determined by Graco to be defective. This warranty applies only when the equipment is installed, operated and maintained in accordance with Graco's written recommendations.

This warranty does not cover, and Graco shall not be liable for general wear and tear, or any malfunction, damage or wear caused by faulty installation, misapplication, abrasion, corrosion, inadequate or improper maintenance, negligence, accident, tampering, or substitution of non-Graco component parts. Nor shall Graco be liable for malfunction, damage or wear caused by the incompatibility of Graco equipment with structures, accessories, equipment or materials not supplied by Graco, or the improper design, manufacture, installation, operation or maintenance of structures, accessories, equipment or materials not supplied by Graco.

This warranty is conditioned upon the prepaid return of the equipment claimed to be defective to an authorized Graco distributor for verification of the claimed defect. If the claimed defect is verified, Graco will repair or replace free of charge any defective parts. The equipment will be returned to the original purchaser transportation prepaid. If inspection of the equipment does not disclose any defect in material or workmanship, repairs will be made at a reasonable charge, which charges may include the costs of parts, labor, and transportation.

THIS WARRANTY IS EXCLUSIVE, AND IS IN LIEU OF ANY OTHER WARRANTIES, EXPRESS OR IMPLIED, INCLUDING BUT NOT LIMITED TO WARRANTY OF MERCHANTABILITY OR WARRANTY OF FITNESS FOR A PARTICULAR PURPOSE.

Graco's sole obligation and buyer's sole remedy for any breach of warranty shall be as set forth above. The buyer agrees that no other remedy (including, but not limited to, incidental or consequential damages for lost profits, lost sales, injury to person or property, or any other incidental or consequential loss) shall be available. Any action for breach of warranty must be brought within two (2) years of the date of sale.

GRACO MAKES NO WARRANTY, AND DISCLAIMS ALL IMPLIED WARRANTIES OF MERCHANTABILITY AND FITNESS FOR A PARTICULAR PURPOSE, IN CONNECTION WITH ACCESSORIES, EQUIPMENT, MATERIALS OR COMPONENTS SOLD BUT NOT MANUFACTURED BY GRACO. These items sold, but not manufactured by Graco (such as electric motors, switches, hose, etc.), are subject to the warranty, if any, of their manufacturer. Graco will provide purchaser with reasonable assistance in making any claim for breach of these warranties.

In no event will Graco be liable for indirect, incidental, special or consequential damages resulting from Graco supplying equipment hereunder, or the furnishing, performance, or use of any products or other goods sold hereto, whether due to a breach of contract, breach of warranty, the negligence of Graco, or otherwise.

FOR GRACO CANADA CUSTOMERS

The Parties acknowledge that they have required that the present document, as well as all documents, notices and legal proceedings entered into, given or instituted pursuant hereto or relating directly or indirectly hereto, be drawn up in English. Les parties reconnaissent avoir convenu que la rédaction du présente document sera en Anglais, ainsi que tous documents, avis et procédures judiciaires exécutés, donnés ou intentés, à la suite de ou en rapport, directement ou indirectement, avec les procédures concernées.

Graco Information

For the latest information about Graco products, visit www.graco.com.

For patent information, see www.graco.com/patents.

TO PLACE AN ORDER, contact your Graco distributor or call 1-800-690-2894 to identify the nearest distributor.

All written and visual data contained in this document reflects the latest product information available at the time of publication. Graco reserves the right to make changes at any time without notice.

Original instructions. This manual contains English. MM 311020

Graco Headquarters: Minneapolis

International Offices: Belgium, China, Japan, Korea

GRACO INC. AND SUBSIDIARIES • P.O. BOX 1441 • MINNEAPOLIS MN 55440-1441 • USA

Copyright 2012, Graco Inc. All Graco manufacturing locations are registered to ISO 9001.

www.graco.com

Revision Z, October 2015