

# Instructions/Parts List



Manual Electrostatic Air-Assisted

# PRO™ Xs4 AA Spray Gun

309295J

**For use with Class I Group D or Class II 2 G spray materials.**

100 psi (0.7 MPa, 7 bar) Maximum Air Inlet Pressure

3000 psi (21 MPa, 210 bar) Maximum Working Fluid Pressure



## Important Safety Instructions

Read all warnings and instructions in this manual.  
Save these instructions.

See for page 2 Table of Contents and page 3 for List of Models.

U.S. Patent 7,226,004

Smart Model

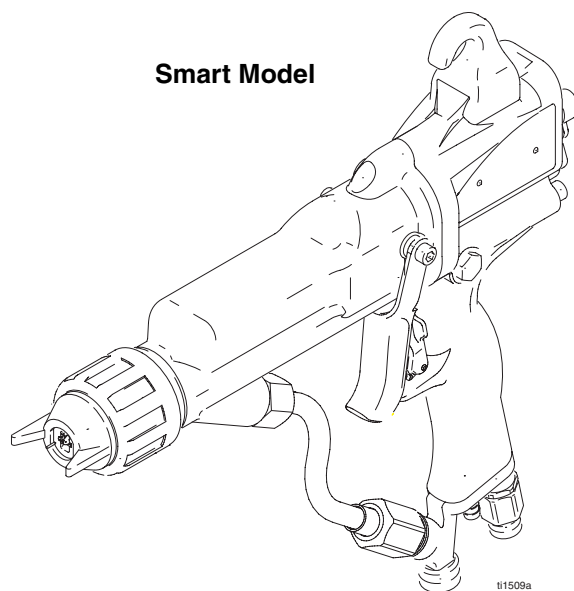

t11509a

Standard Model

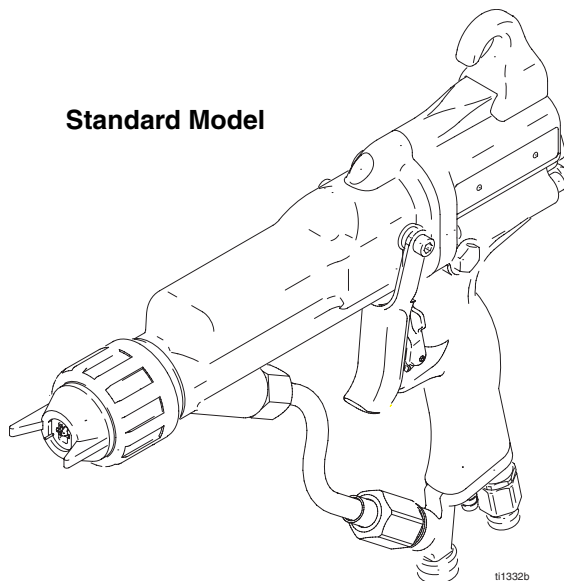

t11332b



PROVEN QUALITY. LEADING TECHNOLOGY.

# Table of Contents

<b>List of Models</b> .....	<b>3</b>	<b>Troubleshooting</b> .....	<b>22</b>
<b>Symbols</b> .....	<b>4</b>	Spray Pattern Troubleshooting .....	22
Warning Symbol .....	4	Gun Operation Troubleshooting .....	23
Caution Symbol .....	4	Electrical Troubleshooting .....	24
<b>Warning</b> .....	<b>5</b>	<b>Repair</b> .....	<b>25</b>
<b>Introduction</b> .....	<b>7</b>	Pressure Relief Procedure .....	25
How the Electrostatic AA Spray Gun Works .....	7	Prepare the Gun for Service .....	26
Gun Overview .....	8	Tools Needed .....	26
<b>Installation</b> .....	<b>9</b>	Tip Guard, Air Cap, Spray Tip, or Seat Housing Replacement .....	27
Install the System .....	9	Electrode Replacement .....	29
Warning Sign .....	9	Fluid Tube Replacement .....	30
Ventilate the Spray Booth .....	9	Fluid Filter Removal .....	30
Connect the Air Line .....	11	Fluid Needle Replacement .....	31
Connect the Exhaust Tube .....	11	Barrel Removal .....	32
Connect the Fluid Line .....	12	Barrel Installation .....	32
Filter the Fluid .....	12	Power Supply Removal and Replacement .....	33
Select a Spray Tip .....	12	Turbine Alternator Removal and Replacement .....	34
Grounding .....	13	Atomizing Air Adjustment Valve Repair .....	35
Check Electrical Grounding .....	14	Air Valve Repair .....	36
Check Fluid Resistivity .....	15	ES ON/OFF Valve Repair .....	37
Check Fluid Viscosity .....	15	<b>Parts</b> .....	<b>38</b>
<b>Operation</b> .....	<b>16</b>	<b>Accessories</b> .....	<b>46</b>
Low Voltage Adjustment (Smart Guns Only) .....	16	Air Line Accessories .....	46
<b>Maintenance</b> .....	<b>17</b>	Fluid Line Accessories .....	46
Flush the Spray Gun .....	17	Gun Accessories .....	47
<b>Electrical Tests</b> .....	<b>19</b>	Miscellaneous Accessories .....	47
Test Gun Resistance .....	19	<b>Spray Tip Selection Chart</b> .....	<b>48</b>
Test Power Supply Resistance .....	20	<b>Technical Data</b> .....	<b>49</b>
Test Barrel Resistance .....	21	<b>Graco Standard Warranty</b> .....	<b>50</b>
		<b>Graco Information</b> .....	<b>50</b>

# List of Models

<b>Part No.</b>	<b>Model</b>	<b>Description</b>	<b>Operation Manual</b>
244572, Series C	PRO Xs4 AA	Manual Air-Assisted Spray Gun	309296/3W9296/ 3Z9296
244573, Series C	PRO Xs4 AA	Manual Air-Assisted Spray Gun with smart display	309296/3W9296/ 3Z9296

# Symbols

## Warning Symbol





This symbol alerts you to the possibility of serious injury or death if you do not follow the instructions.

## Caution Symbol



This symbol alerts you to the possibility of damage to or destruction of equipment if you do not follow the instructions.

## ! WARNING

	<p><b>Fire, Explosion, and Electric Shock Hazard</b> Improper grounding, poor air ventilation, open flames, or sparks can cause a hazardous condition and result in a fire, explosion, or electric shock.</p> <ul style="list-style-type: none"> <li>• Electrostatic equipment must be used only by trained, qualified personnel who understand the requirements in this manual.</li> <li>• Ground the equipment, all personnel in or close to the spray area, the object being sprayed, and all conductive objects in the spray area. See <b>Grounding</b>, page 13.</li> <li>• Provide fresh air ventilation to avoid buildup of flammable or toxic vapors when spraying, flushing, or cleaning the gun. Interlock the gun air supply to prevent operation unless ventilating fans are on. See <b>Ventilate the Spray Booth</b> on page 9.</li> <li>• Do not flush with the gun electrostatics on. Do not turn on the gun electrostatics until all solvent is removed from the system.</li> <li>• If there is any static sparking while using the equipment, <b>stop spraying immediately</b>. Identify and correct the problem.</li> <li>• Eliminate all ignition sources such as pilot lights, cigarettes, and static arcs from plastic drop cloths. Do not plug in or unplug power cords or turn lights on or off in the spray area. Check gun resistance daily. See <b>Test Gun Resistance</b> on page 19.</li> <li>• Use cleaning solvents with the highest possible flash point, preferably above ambient temperature.</li> <li>• Keep the spray area free of debris and rags. Do not store solvent and flammable fluids in the spray area.</li> <li>• Use only non-sparking tools to clean residue from the booth and hangers.</li> </ul>
	<p><b>Skin Injection Hazard</b> Spray from the gun, hose leaks, or ruptured components can inject fluid into your body and cause an extremely serious injury, including the need for amputation. Splashing fluid in the eyes or on the skin can also cause serious injury.</p> <ul style="list-style-type: none"> <li>• Fluid injected into the skin might look like just a cut, but is a serious injury. <b>Get immediate surgical treatment.</b></li> <li>• Do not point the gun at anyone or at any part of the body. Do not put your hand or fingers over the spray tip. Do not stop or deflect fluid leaks with your hand, body, glove, or rag.</li> <li>• Never spray without the tip guard in place.</li> <li>• Lock the trigger safety when you stop spraying.</li> <li>• Follow the <b>Pressure Relief Procedure</b>, page 25, when you stop spraying and before cleaning, checking, or repairing equipment.</li> <li>• Check the hoses and couplings daily. Replace worn, damaged, or loose parts immediately. Permanently coupled hoses cannot be repaired; replace the entire hose.</li> <li>• Tighten all fluid connections before each use.</li> </ul>
	<p><b>Toxic Fluid Hazard</b> Hazardous fluids or toxic fumes can cause a serious injury or death if splashed in the eyes or on the skin, swallowed, or inhaled.</p> <ul style="list-style-type: none"> <li>• Know the specific hazards of the fluid you are using. Read the fluid manufacturer's warnings.</li> <li>• Store hazardous fluid in an approved container. Dispose of the hazardous fluid according to all local, state, and national guidelines.</li> <li>• Wear appropriate protective clothing, gloves, eyewear, and respirator.</li> </ul>

## **WARNING**



### **Equipment Misuse Hazard**

Equipment misuse can cause the equipment to rupture, malfunction, or start unexpectedly and result in a serious injury.

- This equipment is for professional use only.
- Read all manuals, tags, and labels before operating the equipment.
- Use the equipment only for its intended purpose. If you are uncertain, call your Graco distributor.
- Do not alter or modify equipment. Use only genuine Graco parts and accessories.
- Check the equipment daily. Repair or replace worn or damaged parts immediately.
- Do not exceed the maximum working pressure of the lowest rated system component. Maximum working fluid pressure of this equipment is **3000 psi (21 MPa, 210 bar)**.
- Use fluids and solvents that are compatible with the equipment wetted parts. See the **Technical Data** section of all equipment manuals. Read the fluid and solvent manufacturer's warnings.
- Route the hoses away from traffic areas, sharp edges, moving parts, and hot surfaces. Do not expose Graco hoses to temperatures above 180°F (82°C) or below -40°F (-40°C).
- Wear hearing protection when operating this equipment.
- Comply with all applicable local, state, and national fire, electrical, and other safety regulations.

# Introduction

## How the Electrostatic AA Spray Gun Works

### **WARNING**

#### **Skin Injection Hazard**



**Remember, this is not an air spray gun.**  
For your safety, read and follow all Warnings in this manual.

The air-assisted spray gun combines airless and air spraying concepts. The spray tip shapes the fluid into a fan pattern, as does a conventional airless spray tip. Air from the air cap further atomizes the fluid and completes the atomization of the fluid tails to produce a uniform pattern.

As the gun is triggered, part of the regulated air operates the turbine and the rest of the air atomizes the fluid being sprayed. The turbine generates power, which is converted by the power cartridge to supply high voltage current to the gun's electrode.

The regulated air that is directed to the air cap can be further controlled using the gun's atomizing air adjustment valve. This valve can be used to restrict air flow to the air cap while maintaining sufficient air flow to the turbine. The atomizing air adjustment valve does not control pattern width. To change pattern width, a new tip size must be used.

The high working fluid pressure of this gun provides the power needed to atomize higher solids materials.

The gun's internal power supply provides high voltage current. The fluid is electrostatically charged as it passes the electrode. The charged fluid is attracted to the grounded workpiece, wrapping around and evenly coating all surfaces.

**NOTE:** For airless atomization, if desired, turn the gun's atomizing air adjustment valve completely off. Closing this valve does not affect turbine operation.

# Gun Overview

The electrostatic gun includes the following controls. See FIG. 1.

- **Air cap/tip guard and spray tip.** Never spray without the tip guard. See page 48 for spray tip sizes.
- **Trigger safety lock.** Prevents the gun from spraying.
- **Atomizing AIR adjustment valve.** Adjusts atomizing air.

- **ES ON/OFF valve.** Turns electrostatics ON (I) or OFF (O).
- **ES INDICATOR (standard gun only).** Green when ES is ON (I).
- **Voltage/current DISPLAY (smart models only).** Shows voltage (V) and current (A). Green=spray, yellow/red=see Troubleshooting, page 24.
- **ES HI/LO switch (smart models only).** Sets voltage to HI or LO (factory settings).
- **LO voltage adjustment (smart models only).** Remove plug to adjust to four settings.

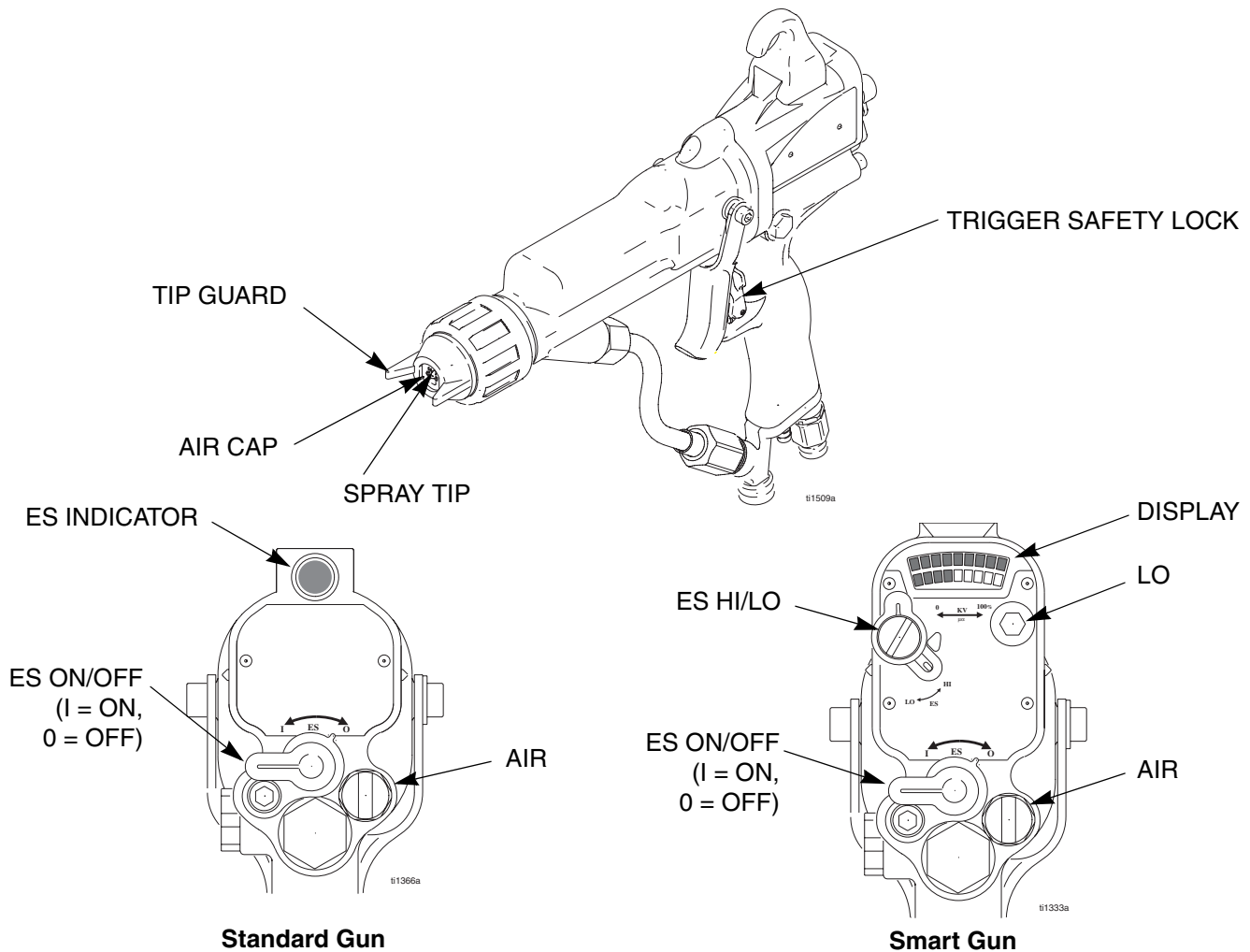



Fig. 1. Gun Overview





# Installation

## Install the System

**WARNING**

**Fire, Explosion, and Electric Shock Hazard**

Installing and servicing this equipment requires access to parts which may cause electric shock or other serious injury if work is not performed properly.

- Do not install or service this equipment unless you are trained and qualified.
- Be sure your installation complies with National, State and Local codes for the installation of electrical apparatus in a Class I, Group D or a Class II 2G Hazardous Location.
- Comply with all applicable local, state, and national fire, electrical, and other safety regulations.

FIG. 2. shows a typical electrostatic air-assisted spray system. It is not an actual system design. For assistance in designing a system to suit your particular needs, contact your Graco distributor.



## Warning Sign

Mount warning signs in the spray area where they can easily be seen and read by all operators. An English Warning Sign is provided with the gun.

## Ventilate the Spray Booth

**WARNING**

**Flammable or Toxic Vapor Hazard**

Provide fresh air ventilation to avoid the buildup of flammable or toxic vapors when spraying, flushing, or cleaning the gun. Do not operate the gun unless ventilation fans are operating.

Electrically interlock the gun air supply with the ventilators to prevent gun operation without ventilating fans operating. Check and follow all National, State, and Local codes regarding air exhaust velocity requirements.

**NOTE:** High velocity air exhaust will decrease the operating efficiency of the electrostatic system. Air exhaust velocity of 100 ft/min (31 linear meters/minute) should be sufficient.

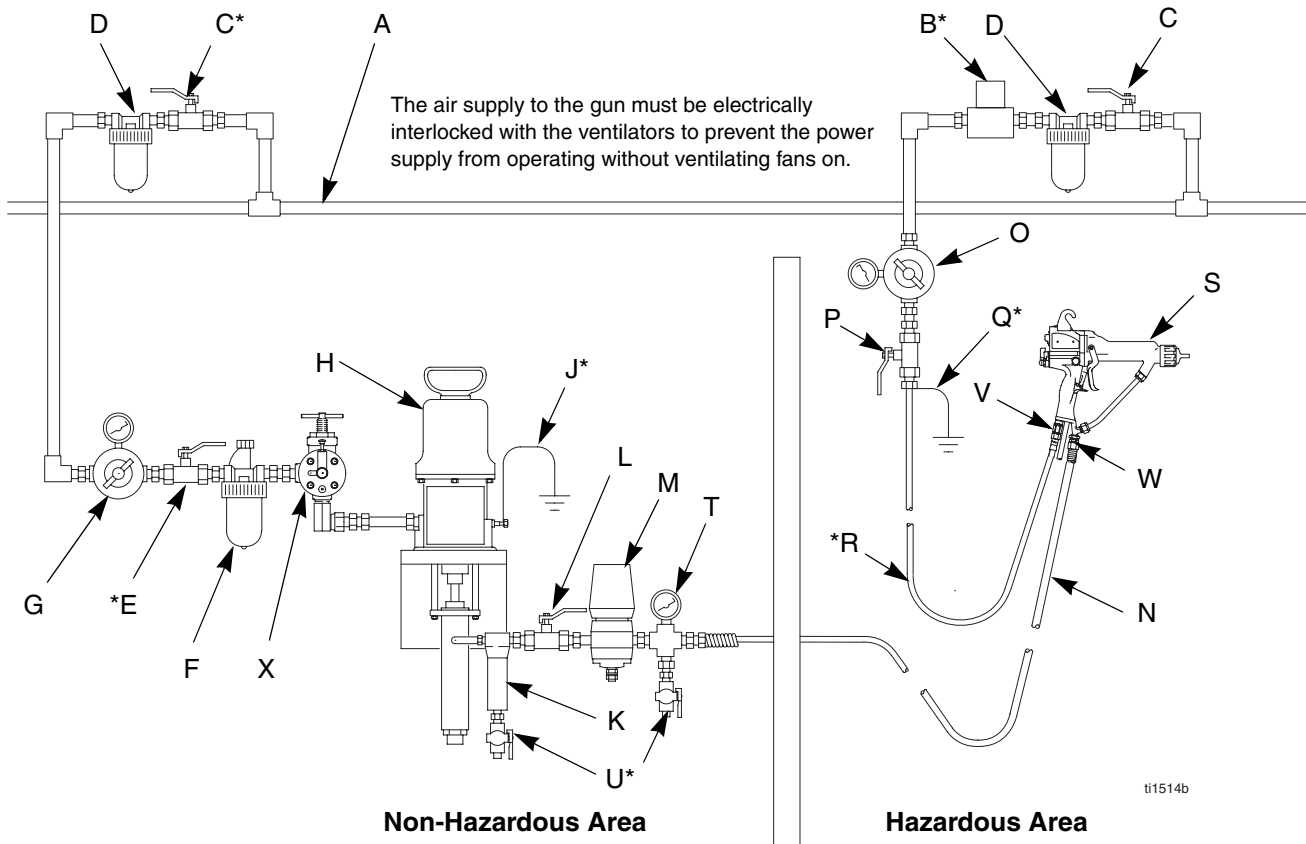

**Fig. 2. Typical Installation Key**

- |    |  |    |   |
|----|--|----|---|
| A  | Main Air Supply Line                           | O  | Gun Air Regulator   |
| B* | Ventilation Fan Interlock Solenoid Valve       | P  | Gun Air Supply Line Shutoff Valve   |
| C* | Main Air Supply Shutoff Valve (bleed-type)     | Q* | Air Hose Ground Wire  |
| D  | Air Line Filter/Water Separator                | R* | Graco Grounded Air Hose   |
| E* | Pump Air Supply Shutoff Valve (bleed-type)     | S  | Electrostatic Air-Assisted Spray Gun  |
| F  | Air Line Lubricator                            | T  | Fluid Pressure Gauge  |
| G  | Air Pressure Regulator                         | U* | Fluid Drain Valve   |
| H  | Pump   | V  | Gun Air Inlet   |
| J* | Pump Ground Wire                               | W  | Gun Fluid Inlet   |
| K  | Fluid Filter                                   | X  | Pump Runaway Valve  |
| L  | Fluid Supply Line Shutoff Valve                | *  | Required for safe operation. Must be purchased separately. <b>NOTE:</b> Solenoid valve (B) is not offered as a Graco accessory. |
| M  | Fluid Pressure Regulator                       |    |   |
| N  | Grounded Fluid Supply Line, with spring guards |    |   |

## Connect the Air Line

### WARNING

#### Electric Shock Hazard



To reduce the risk of electric shock or other serious injury, the air supply hose must be electrically connected to a true earth ground. **Use only Graco Grounded Air Supply Hose.**

1. Connect the Graco Grounded Air Supply Hose (R) between the air supply line and the gun's air inlet (V). The gun air inlet fitting has a left-hand thread. Connect the air supply hose ground wire (Q) to a true earth ground.
2. Install an air line filter/water separator (D) on the air line to ensure a dry, clean air supply to the gun. Dirt and moisture can ruin the appearance of your finished workpiece and can cause the gun to malfunction.

### WARNING

#### Skin Injection Hazard



To reduce the risk of serious injury due to component rupture, including fluid injection, pump pressure must be limited by the pump air regulator. Do not rely on the gun fluid regulator to limit the fluid pressure to the gun.

The fluid supply pump must be prevented from producing a fluid pressure greater than the 3000 psi (21 MPa, 210 bar) *Maximum Working Fluid Pressure* of the gun. For example, the air supply pressure to a 30:1 ratio pump must not exceed 100 psi (0.7 MPa, 7 bar).

3. Install a bleed-type air regulator (G, O) on the pump and gun air supply lines to control air pressure to the pump and gun.

### WARNING

#### Skin Injection Hazard



The bleed-type air valve (E) is required in your system to relieve air trapped between the valve and the pump after the air regulator is shut off. Trapped air can cause the pump to cycle unexpectedly, which can result in serious injury, including fluid injection and splashing fluid in the eyes or on the skin.

4. Install a bleed-type air valve (E) on the pump air line to shut off air to the pump. Install an additional bleed-type air valve (C) on the main air line (A) to isolate the accessories for servicing.
5. Install an air shutoff valve (P) on each gun air supply line to shut off air to the gun(s).

## Connect the Exhaust Tube

Press the exhaust tube (38) onto the barbed adapter on the bottom of the gun handle. Secure the tube with the clamp (39).

## Connect the Fluid Line

1. Before connecting the fluid line (N), blow it out with air and flush it with solvent. Use solvent which is compatible with the fluid to be sprayed.
2. Install a fluid regulator (M) on the fluid line to control fluid pressure to the gun.

 **WARNING**

**Skin Injection Hazard**

 The fluid drain valve (U) is required in your system to assist in relieving fluid pressure in the displacement pump, hose and gun. Triggering the gun to relieve pressure may not be sufficient. Install a drain valve close to the pump's fluid outlet. The drain valve reduces the risk of serious injury, including fluid injection and splashing in the eyes or on the skin.

3. Install a drain valve (U) near the pump outlet.
4. Connect the fluid line to the 1/4 npsm gun fluid inlet (W).
5. Before running any paint through the spray gun, flush it out with a compatible solvent.

## Filter the Fluid

Install a fluid filter (K) at the pump outlet to remove particles and sediment which could clog the spray tip.

The gun includes an inline fluid filter (1) for additional filtration.

## Select a Spray Tip

 **WARNING**

**Skin Injection Hazard**

 To reduce the risk of a fluid injection injury, always follow the **Pressure Relief Procedure**, page 25, before removing or installing the spray tip, air cap, or tip guard.

The fluid output and pattern width depend on the size of the spray tip, the fluid viscosity, and the fluid pressure. Use the **Spray Tip Selection Chart**, page 48, as a guide for selecting the appropriate spray tip for your application.

Refer to the gun operation manual to install the spray tip.

# Grounding

WARNING

**Fire, Explosion, and Electric Shock Hazard**



When operating the electrostatic gun, any ungrounded objects in the spray area (people, containers, tools, etc.) can become electrically charged. Improper grounding can result in static sparking, which can cause a fire, explosion, or electric shock. Follow the grounding instructions below.



When operating the electrostatic gun, any ungrounded objects in the spray area (people, containers, tools, etc.) can become electrically charged. Improper grounding can result in static sparking, which can cause a fire, explosion, or electric shock. Follow the grounding instructions below.

The following are minimum grounding requirements for a basic electrostatic system. Your system may include other equipment or objects which must be grounded. Check your local electrical code for detailed grounding instructions. Your system must be connected to a true earth ground.

- *Pump:* ground the pump by connecting a ground wire and clamp as described in your separate pump instruction manual.

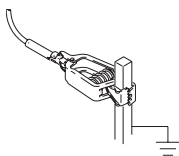

- *Electrostatic Air-Assisted Spray Gun:* ground the gun by connecting the Graco Grounded Air Hose and connecting the air hose ground wire to a true earth ground. See **Check Electrical Grounding**, page 14.

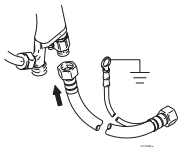

- *Air compressors:* ground the equipment according to the manufacturer's recommendations.
- *All air and fluid lines* must be properly grounded. Use only grounded hoses with a maximum of 100 feet (30.5 m) combined hose length to ensure grounding continuity.

- *All persons entering the spray area:* shoes must have conductive soles, such as leather, or personal grounding straps must be worn. Do not wear shoes with non-conductive soles such as rubber or plastic. If gloves are necessary, wear the conductive gloves that are supplied with the gun. If non-Graco gloves are worn, cut off fingers or palm area of glove, to ensure your hand contacts the grounded gun handle.



- *Object being sprayed:* keep the workpiece hangers clean and grounded at all times. Resistance must not exceed 1 megohm.

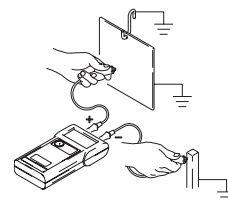

- *The floor of the spray area:* must be electrically conductive and grounded. Do not cover the floor with cardboard or any non-conductive material which would interrupt grounding continuity.

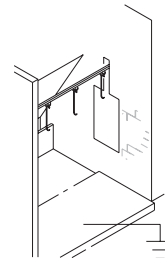

- *Flammable liquids in the spray area:* must be kept in approved, grounded containers. Do not use plastic containers. Do not store more than the quantity needed for one shift.

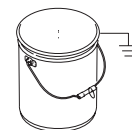

- *All electrically conductive objects or devices in the spray area:* including fluid containers and wash cans, must be properly grounded.

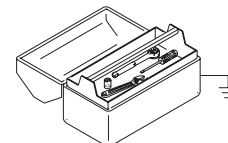



# Check Electrical Grounding



## WARNING

**Fire, Explosion, and Electric Shock Hazard**





Megohmmeter Part No. 241079 (AA-see FIG. 3.) is not approved for use in a hazardous area. To reduce the risk of sparking, do not use the megohmmeter to check electrical grounding unless:

- The gun has been removed from the hazardous area;
- Or all spraying devices in the hazardous area are turned off, ventilation fans in the hazardous area are operating, and there are no flammable vapors in the area (such as open solvent containers or fumes from spraying).

Failure to follow this warning could cause fire, explosion, and electric shock and result in serious injury and property damage.

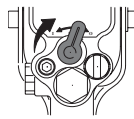
1. Have a qualified electrician check the electrical grounding continuity of the spray gun and air hose.
2. Turn the ES ON/OFF valve OFF.



3. Turn off the air and fluid supply to the gun. The fluid hose must not have any fluid in it.
4. Make sure the grounded air hose (R) is connected and the hose ground wire is connected to a true earth ground.

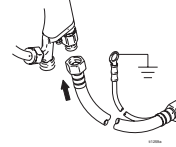

5. Measure the resistance between the gun handle (BB) and a true earth ground (CC). Use an applied voltage of 500 minimum to 1000 volts maximum. The resistance should not exceed 1 megohm. See FIG. 3.
6. If the resistance is greater than 1 megohm, check the tightness of the ground connections and be sure the air hose ground wire is connected to a true earth ground. If the resistance is still too high, replace the air hose.

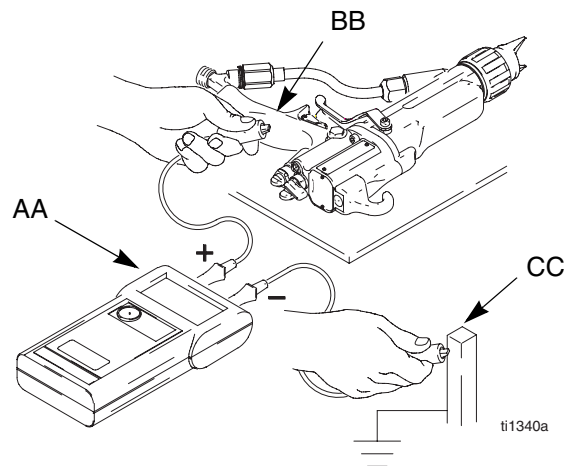



**Fig. 3. Check Gun Grounding**

## Check Fluid Resistivity

**WARNING**

**Fire, Explosion, and Electric Shock Hazard**

Check the fluid resistivity in a non-hazardous area only. Resistance Meter 722886 and Probe 722860 are not approved for use in a hazardous area.

Failure to follow this warning could cause fire, explosion, electric shock and result in serious injury and property damage.

Graco Part No. 722886 Resistance Meter and 722860 Probe are available as accessories to check that the resistivity of the fluid being sprayed meets the requirements of an electrostatic air-assisted spray system.

Follow the instructions included with the meter and probe. Readings of 25 megohms-cm and above provide the best electrostatic results.

## Check Fluid Viscosity

To check fluid viscosity you will need:

- a viscosity cup
  - a stopwatch.
1. Completely submerge the viscosity cup in the fluid. Lift the cup out quickly, starting the stopwatch as soon as the cup is completely removed.
  2. Watch the stream of fluid coming from the bottom of the cup. As soon as there is a break in the stream, shut off the stopwatch.
  3. Record the fluid type, elapsed time, and size of the viscosity cup.
  4. If the viscosity is too high or too low, contact the material supplier and adjust as necessary.

# Operation



Refer to the gun operation manual (supplied) for Setup, Shutdown, and Daily Care procedures.

**INSTRUCTIONS**

## Low Voltage Adjustment (Smart Guns Only)

The ES HI/LO switch enables you to switch between full voltage and a lower voltage output. The lower voltage is factory set, but can be adjusted.

1. Set the ES HI/LO switch to LO.
2. Remove the LOW VOLTAGE adjustment plug (53). Set the desired voltage, using a small screwdriver to slide switches 1 and 2 ON or OFF, according to Table 1 . Also see FIG. 4.

**Table 1: Low Voltage Adjustment**

1	2	kV
ON	ON	70
ON	OFF	60
OFF	ON	50
OFF	OFF	40

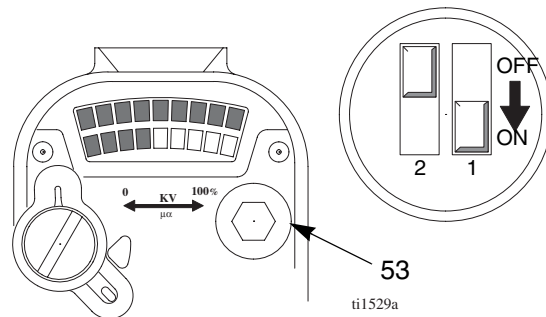

**Fig. 4. Low Voltage Adjustment Switches**



# Maintenance



INSTRUCTIONS

Refer to the gun operation manual (supplied) for Daily Care and Cleaning procedures.

## Flush the Spray Gun

Flush the gun before changing colors, at the end of the day, before storing, and before repairing the gun.

1. Turn the ES ON/OFF valve OFF.

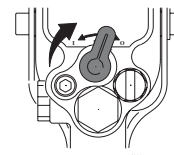

### ! WARNING

#### Fire, Explosion, and Electric Shock Hazard



To reduce the risk of fire, explosion, or electric shock, turn the ES ON/OFF valve OFF before flushing the gun.

### ! WARNING

#### Skin Injection Hazard



To reduce the risk of a fluid injection injury, always follow the **Pressure Relief Procedure**, page 25, whenever you are instructed to relieve the pressure.

2. Relieve the pressure.

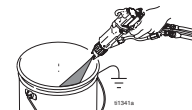

### ! CAUTION

Flush the gun with a non-conductive, compatible solvent. Conductive solvents can cause the gun to malfunction.

Do not use methylene chloride as a flushing or cleaning solvent with this gun as it will damage nylon components.

3. Remove and clean the air cap and the spray tip.

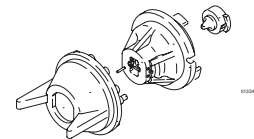

*Continued on page 18.*

## Maintenance

4. Change the fluid source to solvent, or disconnect the fluid line and connect a solvent supply line to the gun.

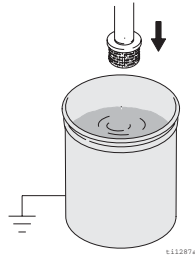

5. Point the gun into a grounded metal pail. Flush until clean solvent flows from the gun.

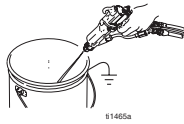

6. Relieve the pressure. Lock the trigger.

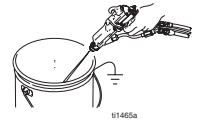

7. Shut off or disconnect the solvent line.

8. Hang the gun from its hook, with the nozzle pointing down.

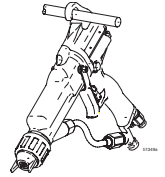

9. When ready to spray again, reconnect the fluid supply line. Follow the Setup procedure in the Gun Operation Manual.

# Electrical Tests

Electrical components inside the gun affect performance and safety. The following procedures test the condition of the power supply (18) and barrel (16), and electrical continuity between components.

## CAUTION

The barrel resistor cartridge is part of the barrel and is not replaceable. To avoid destroying the gun barrel, do not attempt to remove the barrel resistor.

Use megohmmeter Part No. 241079 (AA) with an applied voltage of 500 V. Connect the leads as shown.

## WARNING

### Fire, Explosion, and Electric Shock Hazard



Megohmmeter Part No. 241079 (AA-see FIG. 5.) is not approved for use in a hazardous area. To reduce the risk of sparking, do not use the megohmmeter to check electrical grounding unless:

- The gun has been removed from the hazardous area;
- Or all spraying devices in the hazardous area are turned off, ventilation fans in the hazardous area are operating, and there are no flammable vapors in the area (such as open solvent containers or fumes from spraying).

Failure to follow this warning could cause fire, explosion, and electric shock and result in serious injury and property damage.

## Test Gun Resistance

1. Flush and dry the fluid passage.
2. Measure resistance between the electrode needle tip (9b) and the air swivel (35); it should be 156-180 megohms. See FIG. 5. If outside this range, go to the next test. If in range, refer to **Electrical Troubleshooting** on page 24 for other possible causes of poor performance.

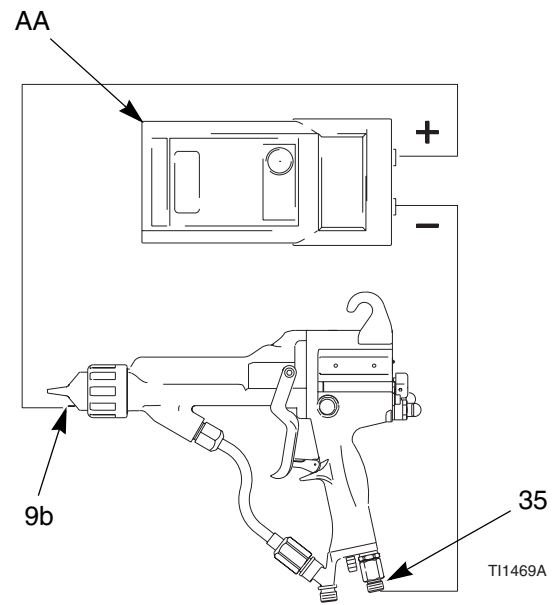

Fig. 5. Test Gun Resistance

## Test Power Supply Resistance

1. Remove the power supply (18), page 33.
  2. Remove the turbine alternator (19) from the power supply, page 34.
  3. Measure resistance from the power supply's ground strips (EE) to the spring (18b). See FIG. 6.
  4. The resistance should be 135-150 megohms. If outside this range, replace the power supply. If in range, proceed to the next test.
  5. If you still have problems, refer to **Electrical Troubleshooting** on page 24 for other possible causes of poor performance, or contact your Graco distributor.
6. Be sure the spring (18b) is in place before reinstalling the power supply.

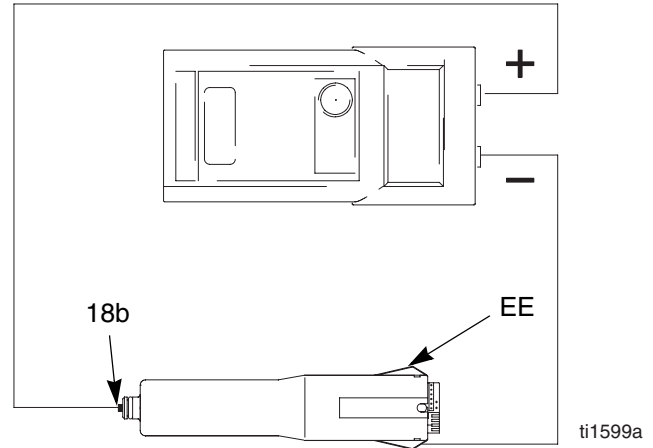

Fig. 6. Test Power Supply Resistance

## Test Barrel Resistance

1. Insert a conductive rod (B) into the gun barrel (removed for the power supply test) and against the metal contact (C) in the front of the barrel.
2. Measure the resistance between the conductive rod (B) and the barrel contact ring (16a). See FIG. 7. The resistance should be 19-29 megohms. If the resistance is incorrect, make sure the metal contact (C) in the barrel and the barrel contact ring (16a) are clean and undamaged.
3. If the resistance is still outside the range, remove the barrel contact ring (16a) and measure the resistance between the conductive rod (B) and the wire lead at the bottom of the contact ring groove.
4. If the resistance is in range, replace the contact ring (16a) with a new one. Press the contact ring firmly into the groove on the front of the barrel.

5. If the resistance is still outside the range, replace the barrel.

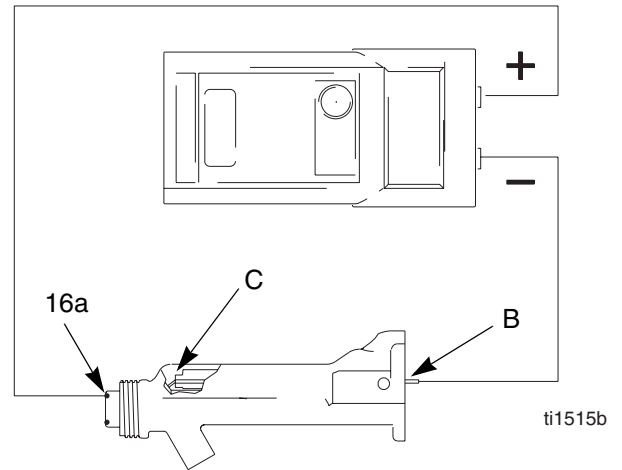

Fig. 7. Test Barrel Resistance

### WARNING

#### Fire, Explosion, and Electric Shock Hazard



The barrel contact ring (16a) is a conductive contact ring, not a sealing o-ring. To reduce the risk of sparking or electric shock, do not remove the barrel contact ring (16a) except to replace it and never operate the gun without the contact ring in place. Do not replace the contact ring with anything but a genuine Graco part.

# Troubleshooting

 **WARNING**

**Electric Shock Hazard**



Installing and servicing this equipment requires access to parts which may cause an electric shock or other serious injury if the work is not performed properly. Do not install or service this equipment unless you are trained and qualified.

 **WARNING**

**Skin Injection Hazard**



To reduce the risk of a fluid injection injury, always follow the **Pressure Relief Procedure** on page 25 whenever you are instructed to relieve the pressure.

**NOTE:** Check all possible remedies in the Troubleshooting Chart before disassembling the gun.

## Spray Pattern Troubleshooting

**NOTE:** Some spray pattern problems are caused by the improper balance between air and fluid.

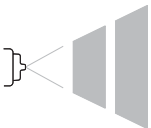
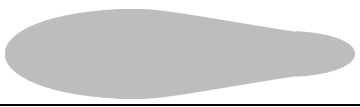
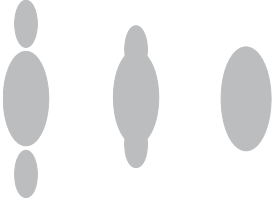
Problem	Cause	Solution
Fluttering or spitting spray. 	No fluid.	Refill supply.
	Air in fluid supply.	Check fluid source. Refill.
Irregular pattern. 	Fluid buildup; partially plugged tip.	Clean. See gun operation manual.
	Worn/damaged tip or air cap holes.	Clean or replace.
Pattern pushed to one side; air cap gets dirty.	Air cap holes plugged.	Clean. See gun operation manual.
Tails in pattern. 	Air pressure too low.	Open atomizing air adjustment valve.
	Fluid pressure too low.	Increase.
Fluid buildup on air cap/tip guard.	Air pressure too high.	Decrease.
	Fluid pressure too low.	Increase.

## Gun Operation Troubleshooting

Problem	Cause	Solution
Excessive spray fog.	Atomizing air pressure too high.	Close atomizing air valve some, or decrease air pressure as low as possible; minimum 40 psi (0.28 MPa, 2.8 bar) needed at gun for full voltage.
	Fluid too thin.	Increase viscosity.
"Orange Peel" finish.	Atomizing air pressure too low.	Open atomizing air valve more or increase gun air inlet pressure; use lowest air pressure necessary.
	Spray tip is too large.	Use smaller tip. See page 48.
	Poorly mixed or filtered fluid.	Remix or refilter fluid.
	Fluid too thick.	Reduce viscosity.
Fluid leaks from the fluid packing area	Worn fluid needle packings or shaft.	Replace fluid needle assembly (26); see page 31.
Air leaks from the front of the gun	Air valve (21) is not seating properly.	Clean and service air valve; see page 36.
Fluid leakage from the front of the gun	Worn or damaged fluid needle ball.	Replace fluid needle (26); see page 31.
	Worn fluid seat housing (2).	Replace seat housing; see page 27.
	Loose spray tip (3).	Tighten retaining ring (27); see page 27.
	Damaged tip seal (3a).	Replace; see page 27.
Gun does not spray	Low fluid supply.	Add fluid if necessary.
	Damaged spray tip (3).	Replace; see page 27.
	Dirty or clogged spray tip (3).	Clean; see gun operation manual.
	Damaged fluid needle (26).	Replace; see page 31.
Dirty air cap	Damaged or plugged air cap (9).	Clean air cap; see gun operation manual.

## Electrical Troubleshooting

Problem	Cause	Solution
Poor wrap.	ES ON/OFF valve OFF (0).*	Turn ON (I).
	Gun air pressure too low.	Check air pressure to gun; minimum 40 psi (0.28 MPa, 2.8 bar) needed at gun for full voltage.
	Atomizing air pressure too high.	Decrease.
	Fluid velocity too high.	Decrease fluid pressure or replace worn tip.
	Incorrect distance from gun to part.	Should be 8-12 in. (200-300 mm).
	Poorly grounded parts.	Resistance must be 1 megohm or less. Clean workpiece hangers.
	Faulty gun resistance.	See "Test Gun Resistance" on page 19.
	Low fluid resistivity.	Check fluid resistivity. See page 15.
	Fluid leaks from the fluid needle (26) packings and causes a short.	Clean the needle cavity. Replace the fluid needle. See page 31.
	Faulty turbine alternator (19).	Be sure the plug is in place on the back of the turbine alternator housing. Remove and test the turbine alternator. See page 34.
	The KV HI-LO lever is on LO.	Check the lever position; replace if needed.
ES indicator or voltage/current display is not lit.	ES ON/OFF valve OFF (0).*	Turn ON (I).
	No power.	Repair/replace alternator turbine; replace power supply. See page 33.
Voltage/current display stays red (smart guns only).	Gun too close to part.	Should be 8-12 in. (200-300 mm).
	Check fluid resistivity.	See "Check Fluid Resistivity" on page 15.
	Dirty gun.	Clean. See Operation Manual.
Operator gets mild shock.	Operator not grounded or is near ungrounded object.	See "Grounding" on page 13.
	Gun not grounded.	See "Check Electrical Grounding" on page 14 and "Test Gun Resistance" on page 19.
Operator gets shock from workpiece.	Workpiece not grounded.	Resistance must be 1 megohm or less. Clean workpiece hangers.

\* ES indicator light is off when the gun is triggered.



# Repair

## Pressure Relief Procedure

### **WARNING**

#### Skin Injection Hazard



The system pressure must be manually relieved to prevent the system from starting or spraying accidentally. Fluid under high pressure can be injected through the skin and cause serious injury. To reduce the risk of an injury from injection, splashing fluid, or electric shock, follow the **Pressure Relief Procedure** whenever you:

- are instructed to relieve the pressure
- stop spraying
- check or repair any of the system equipment
- or install or clean the spray tip.

1. Turn the ES ON/OFF valve OFF.

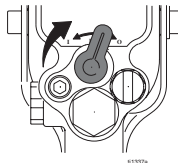

2. Lock the trigger.



3. Turn off the air bleed valves to the fluid source and to the gun.



4. Unlock the trigger.

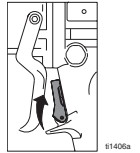

5. Trigger the gun into a grounded metal waste container to relieve the fluid pressure.

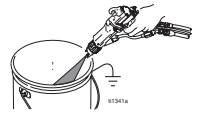

6. Lock the trigger.

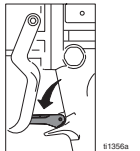

7. Open the pump drain valve and all other fluid drain valves in the system, having a waste container ready to catch the drainage. Leave the drain valve(s) open until you are ready to spray again.

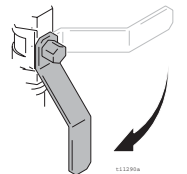

8. If the nozzle or hose is completely clogged or pressure is not fully relieved, slowly loosen the hose end coupling. Now clear the nozzle or hose.

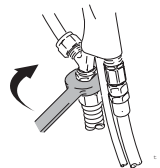

## Prepare the Gun for Service

### **WARNING**

#### Electric Shock Hazard



Installing and repairing this equipment requires access to parts that may cause electric shock or other serious injury if the work is not performed properly. Do not install or service this equipment unless you are trained and qualified.

### **WARNING**

#### Skin Injection Hazard



To reduce the risk of injury, follow the **Pressure Relief Procedure** on page 25 before checking or repairing any part of the system and whenever you are instructed to relieve the pressure.

#### NOTE:

- Check all possible remedies in **Troubleshooting** before disassembling the gun.
- Use a vise with padded jaws to prevent damage to plastic parts.
- Lubricate the power supply o-ring (18a) and the plastic end of the fluid tube (14) with dielectric grease (40).
- Lightly lubricate o-rings and seals with non-silicone grease. Order Part No. 111265 Lubricant. Do not over-lubricate.

- Only use genuine Graco parts. Do not mix or use parts from other PRO Gun models. Note that the air cap, spray tip, and tip guard for this gun are orange.
- Air Seal Repair Kit 244781 is available. The kit must be purchased separately. Kit parts are marked with an asterisk, for example (6\*).

### **WARNING**

Some PRO Xs4 AA Gun replacement parts look similar to other PRO Gun parts but are not interchangeable! **When repairing, do not mix or use other PRO Gun parts that may look similar, but have different part numbers!** Use of parts other than those specified in the PRO Xs4 AA Gun parts lists could alter the grounding continuity of the gun, cause parts to leak or rupture, or cause the gun to malfunction and result in serious injury, fire, explosion, or property damage.

1. Flush the gun, page 17.
2. Relieve the pressure, page 25.
3. Disconnect the gun air and fluid lines.
4. Remove the gun from the worksite. Repair area must be clean.

## Tools Needed

- 2 mm driver (supplied)
- 4 mm driver (supplied)
- Multi-Tool (supplied)
- adjustable wrench
- medium screwdriver
- snap ring pliers

# Tip Guard, Air Cap, Spray Tip, or Seat Housing Replacement

1. Prepare gun for service, page 26.
2. Remove the retaining ring (27), tip guard (4), air cap (9a), and spray tip (3). You may have to turn the air cap with the tip guard to remove it. See FIG. 8.
3. Replace the tip gasket (3a) if damaged.

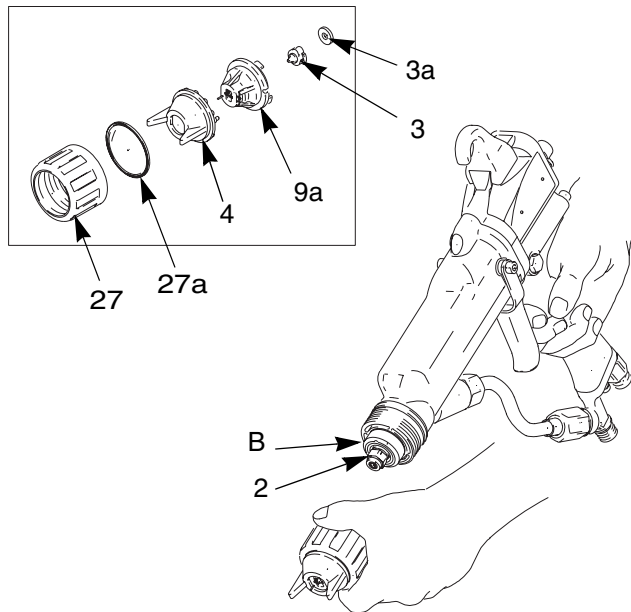

**Fig. 8. Tip Guard, Air Cap, and Spray Tip Replacement**

4. Trigger the gun and remove the seat housing (2) with the tool (37) provided. See FIG. 9.

**CAUTION**

The barrel resistor cartridge (B) is part of the barrel and is not replaceable. To avoid destroying the gun barrel, do not attempt to remove the barrel resistor.

**WARNING**

**Fire, Explosion, and Electric Shock Hazard**

The barrel contact ring (16a) is a conductive contact ring, not a sealing o-ring. To reduce the risk of sparking or electric shock, do not remove the barrel contact ring (16a) except to replace it and never operate the gun without the contact ring in place. Do not replace the contact ring with anything but a genuine Graco part.

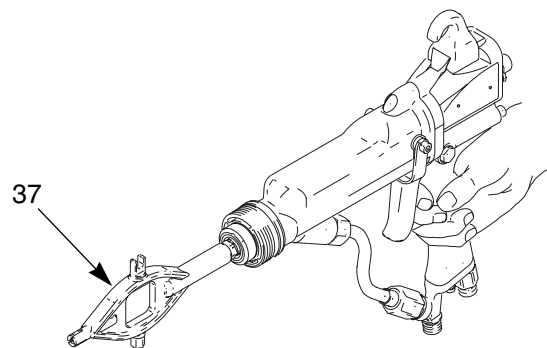

**Fig. 9. Seat Housing Replacement**

*Continued on page 28.*

 **CAUTION**

To avoid damaging the seat housing and gun barrel, never over-tighten the seat housing. Over-tightening may result in improper fluid shut-off.

5. Trigger the gun and install the gray-colored seat housing (2). Tighten until snug, then 1/4 turn more.

 **CAUTION**

To avoid damaging the tip guard (4), orientate the air cap (9a) before tightening the retaining ring (27). Do not turn the cap when the retaining ring is tight.

6. Assemble the spray tip (3), air cap (9a), and tip guard (4). Make sure the electrode (9b) is not damaged or missing. Install the air cap assembly with the retaining ring (27). The u-cup (27a) lips must face forward.

7. Test gun resistance, page 19.

# Electrode Replacement

## **! WARNING**

### Electric Shock Hazard



To reduce the risk of fire, explosion, or electric shock, do not operate the spray gun without the electrode installed in the air cap.

1. Prepare the gun for service, page 26.
2. Remove the air cap assembly, page 27.
3. Pull the electrode (9b) out of the back of the air cap, using a needle-nose pliers.

4. Push the new electrode through the air cap hole. Make sure the short end (BB) of the electrode engages the hole (CC) in the back of the air cap. Press the electrode in place firmly with your fingers. See FIG. 10.
5. Install the air cap assembly, page 27.
6. Test gun resistance, page 19.

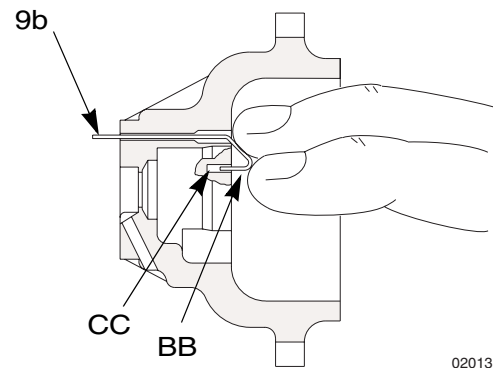

02013

**Fig. 10. Electrode Replacement**

## Fluid Tube Replacement

1. Prepare the gun for service, page 26.
2. Disconnect the bottom fluid tube nut (C). See FIG. 11.
3. Carefully unscrew the top fluid tube nut (D).

### CAUTION

Be careful not to damage the fluid tube assembly (14) when cleaning or installing it, especially the sealing surface (E). If the sealing surface is damaged, the entire fluid tube assembly must be replaced.

4. Apply dielectric grease (40) to the entire length of the plastic extension on the end of the fluid tube (14).
5. Apply low strength thread sealant to the fluid tube nut threads.
6. Install the fluid tube into the gun barrel and tighten the top nut (D) hand-tight, then 1/4 to 1/2 turn with a wrench. There will be a gap between the nut and barrel. Do not overtighten the nut.
7. Make sure the fluid filter (1) is in place in the fluid fitting. Tighten the bottom nut (C) onto the fitting and torque to 20-30 in-lb (2.3-3.4 N•m). Make sure the top nut remains tight.

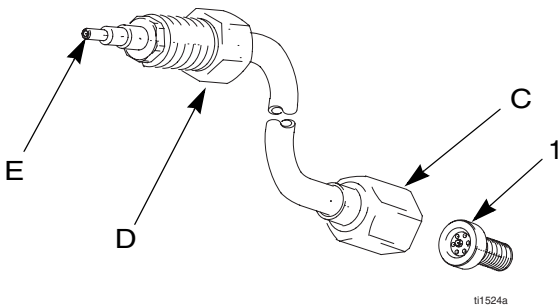

Fig. 11. Fluid Tube Replacement

## Fluid Filter Removal

1. Prepare the gun for service, page 26.
2. Disconnect the bottom fluid tube nut (C).
3. Remove the fluid filter (1) from the fluid fitting. Clean or replace the filter, as needed. See FIG. 12.

**NOTE:** Replacement filters are available in 100 mesh (standard) or 60 mesh sizes. See page 47.

4. Install the fluid filter in the fluid fitting. Tighten the bottom nut (C) onto the fitting and torque to 20-30 in-lb (2.3-3.4 N•m). Make sure the top nut remains tight.

### CAUTION

Be sure the fluid tube (14) is not twisted after tightening the bottom nut (C).

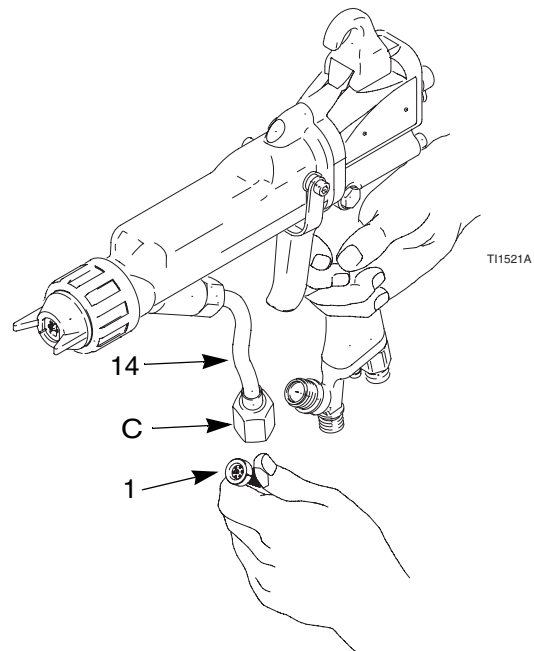
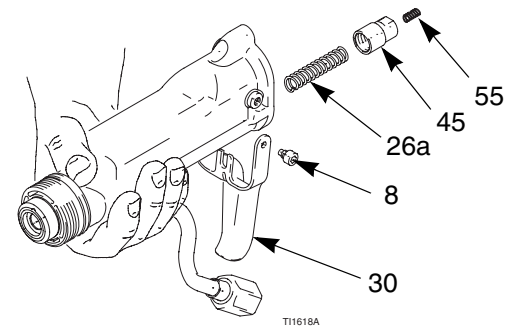

Fig. 12. Fluid Filter Removal

# Fluid Needle Replacement

1. Prepare the gun for service, page 26.
2. Remove the air cap assembly and seat housing, page 27.
3. Remove the barrel (16), page 32.
4. Remove the trigger screws (8) and trigger (30).
5. Remove the spring cap (45) and the spring (26a) from the barrel. See FIG. 13.
6. Place the 2 mm driver (44) in the back of the fluid needle assembly. Push the tool in and turn it counterclockwise about 12 full turns to unthread the needle.
7. Using the u-shaped tool (37), pull back on the packing nut (N) to remove the fluid needle assembly. See FIG. 14.
8. Install the fluid needle assembly in the gun barrel. Push in on the needle with the 2 mm driver (44) and tighten. See FIG. 15.
9. Install the spring (26a).
10. Install the spring cap (45), making sure the grounding spring (55) is in place.
11. Install the trigger (30) and screws (8).
12. Install the barrel (16), page 32.



**Fig. 13. Spring Cap and Springs**

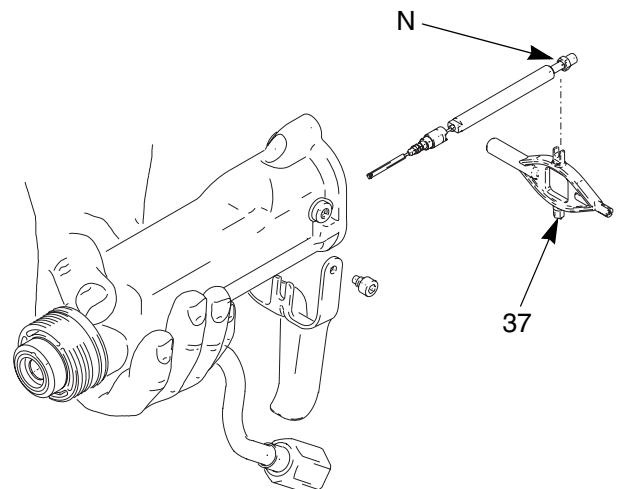

**Fig. 14. Fluid Needle Removal**

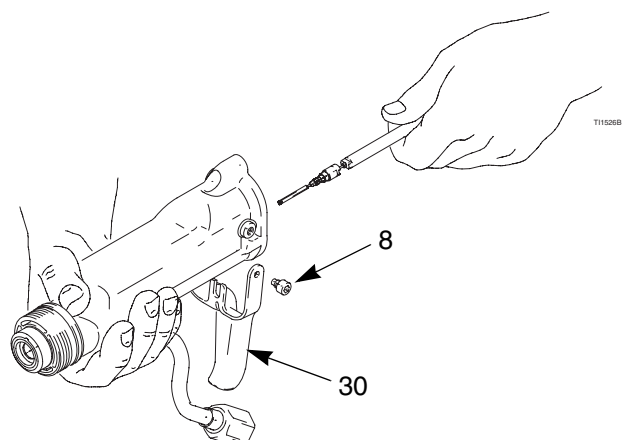

**Fig. 15. Fluid Needle Replacement**

## CAUTION

To avoid damaging the seat housing and gun barrel, never overtighten the seat housing. Overtightening may result in improper fluid shutoff.

13. Install the seat housing and air cap, page 27.
14. Test gun resistance, page 19.

## Barrel Removal

1. Prepare the gun for service, page 26.
2. Carefully loosen the nut (C) from the bracket fluid fitting (13). See FIG. 16.
3. Loosen the three screws (11).

### CAUTION

To avoid damaging the power supply (18), pull the gun barrel straight away from the gun handle. If necessary, gently move the gun barrel from side to side to free it from the gun handle.

4. Hold the gun handle (17) with one hand and pull the barrel (16) straight off the handle.

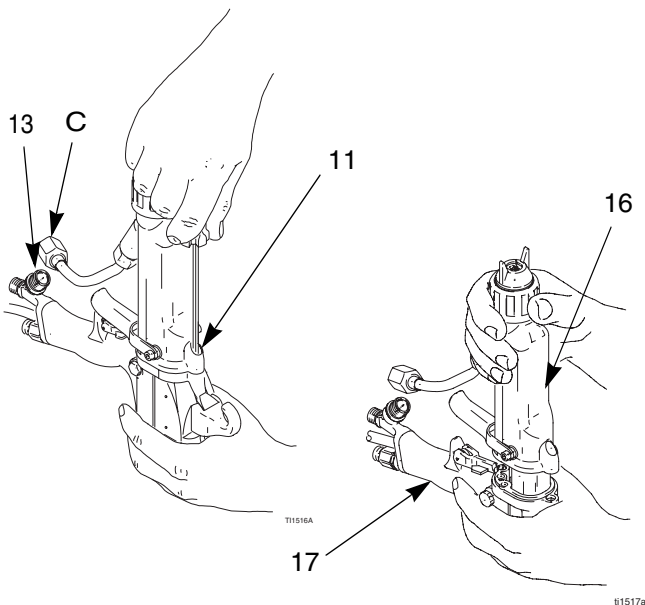

Fig. 16. Barrel Removal

## Barrel Installation

1. Be sure the gasket (10\*, FIG. 17.) and grounding spring (55, FIG. 13.) are in place and the gasket air holes are aligned properly. Replace if damaged.

2. Place the barrel (16) over the power supply (18) and onto the gun handle (17).
3. Tighten the three screws (11) oppositely and evenly (about a half turn past snug).

### CAUTION

Do not over-tighten the screws (11).

4. Make sure the fluid filter (1) is in place in the fluid fitting. Tighten the bottom fluid tube nut (C) onto the bracket (13) fluid fitting and torque to 20-30 in-lb (2.3-3.4 N•m). Make sure the top nut remains tight.

### CAUTION

Be sure the fluid tube (14) is not twisted after tightening the bottom nut (C).

5. Test gun resistance, page 19.

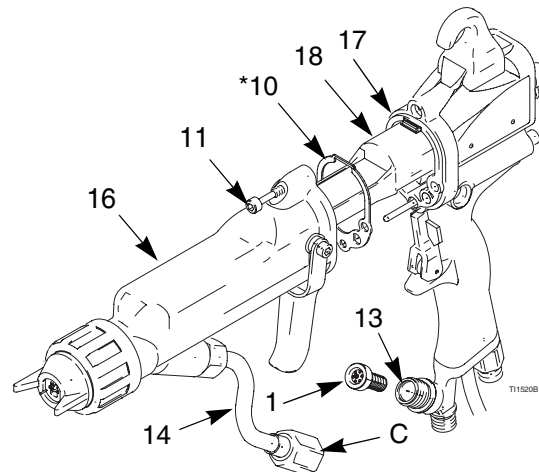

Fig. 17. Barrel Installation



# Power Supply Removal and Replacement

## NOTE:

- Inspect the gun handle power supply cavity for dirt or moisture. Clean with a clean, dry rag.
  - Do not expose gasket (10) to solvents.
- Prepare gun for service, page 26.
  - Remove the barrel (16), page 32.

## CAUTION

Be careful when handling the power supply (18) to avoid damaging it.

- Grasp the power supply (18) with your hand. With a gentle side to side motion, free the power supply/alternator assembly from the gun handle (17), then carefully pull it straight out. *On Smart Models only*, disconnect the flexible circuit (59) from the socket at the top of the handle (17). See FIG. 18.
- Disconnect the 3-wire connector (B) from the power supply. Slide the alternator up and off the power supply. Inspect the power supply and alternator for damage. *On Smart Models only*, disconnect the 6-pin flexible circuit (59) from the power supply.
- Check the power supply resistance, page 20. Replace if necessary.

**NOTE:** Before installing the power supply, make sure the o-rings (18a\*, 19a\*), spring (18b), and pads (19e) are in place.

- On Smart Models only*, connect the 6-pin flexible circuit (59) to the power supply.

- Connect the 3-wire connector (B). Slide the alternator (19) down onto the power supply (18).
- Lubricate the alternator o-ring (19a\*) with non-silicone grease, Part No. 111265. Do not over-lubricate.
- Lubricate the power supply o-ring (18a\*) with dielectric grease (40).
- Insert the power supply/alternator assembly in the gun handle (17). Make sure the ground strips make contact with the handle. *On Smart Models only*, connect the flexible circuit (59) to the socket at the top of the handle. Push the 6-pin connector into the socket to ensure it is properly connected.
- Install the barrel (16), page 32.
- Test gun resistance, page 19.

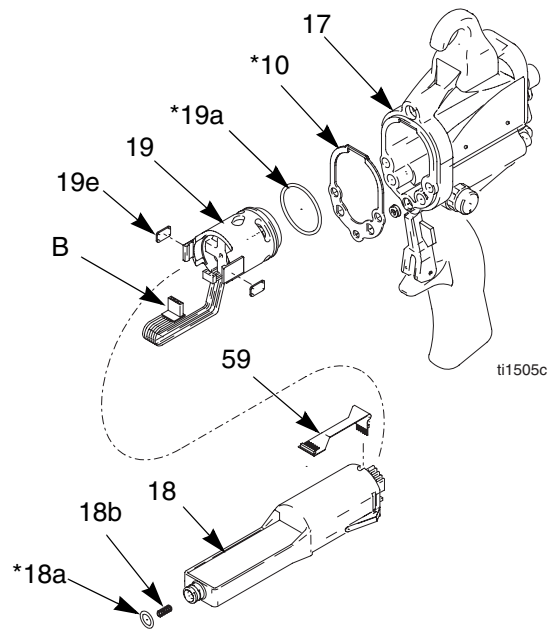

**Fig. 18. Power Supply and Turbine Alternator**

## Turbine Alternator Removal and Replacement

**NOTE:** Replace turbine bearings after 2000 hours of operation. Order Part No. 223688 Bearing Kit.

1. Prepare gun for service, page 26.
2. Remove the power supply/alternator assembly, page 33.
3. Disconnect the alternator from the power supply, page 33.
4. Measure resistance between the two outer terminals of the 3-wire connector (B); it should be 2.5-3.5 ohms. If outside this range, replace the alternator coil.
5. Follow the bearing replacement procedure in the bearing kit manual 308034.
6. Install the alternator on the power supply, page 33.
7. Install the power supply/alternator assembly, page 33.

## Atomizing Air Adjustment Valve Repair

1. Prepare the gun for service, page 26.
2. Place a wrench on the flats of the valve assembly (20) and unscrew it from the handle (17).

**NOTE:** You may replace the valve as an assembly (go to step 9) or as individual parts (steps 3-9).

3. Remove the retaining ring (20a). See FIG. 19.
4. Turn the valve stem (20d) counterclockwise until it comes free from the valve housing (20c).
5. Remove the o-ring (20b).

6. Clean all parts and inspect for wear or damage.

**NOTE:** Use non-silicone grease, Part No. 111265. Do not over-lubricate.

7. When reassembling the atomizing air valve (20), lightly lubricate the valve threads and screw the stem (20d) fully into the housing (20c) until bottomed. Install the o-ring (20b\*), lubricate, and unscrew the valve stem until the o-ring enters the housing.
8. Reassemble the retaining ring (20a). Unscrew the valve stem from the housing until it is stopped by the retaining ring.
9. Screw the valve assembly (20) into the gun handle, using a wrench on the flats of the housing. Torque to 15-25 in-lb (1.7-2.8 N•m).

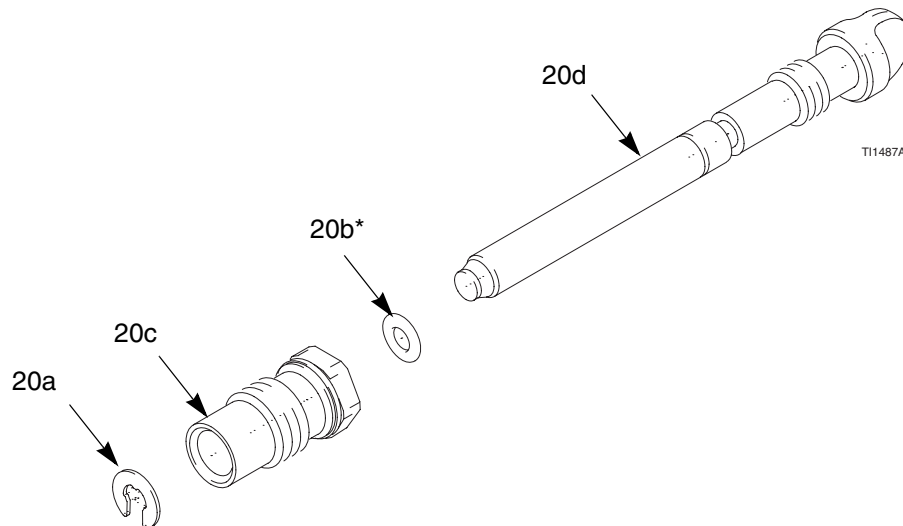

**Fig. 19. Atomizing Air Adjustment Valve**

## Air Valve Repair

1. Prepare the gun for service, page 26.
2. Remove the barrel, page 32.
3. Remove the air valve cap (25) from the handle (17). Remove the spring (15). See Fig. 20.

### CAUTION

Clean all parts in non-conductive solvent compatible with the fluid being used, such as xylol or mineral spirits. Use of conductive solvents can cause the gun to malfunction.

4. Remove the air valve (21) with a pliers. Inspect the the rubber sealing surface and replace the air valve if damaged.

### CAUTION

When removing the air valve (21) be careful not to damage the seat area. The rubber seal is not removable.

5. Inspect the u-cup (6\*). Do not remove the u-cup unless damaged. If removed, install the new one with its lips facing into the gun handle (17).
6. Install the air valve (21) and spring (15) into the gun handle (17).
7. Install the air valve cap (25). Torque to 15-25 in-lb (1.7-2.8 N•m).
8. Install the barrel, page 32.

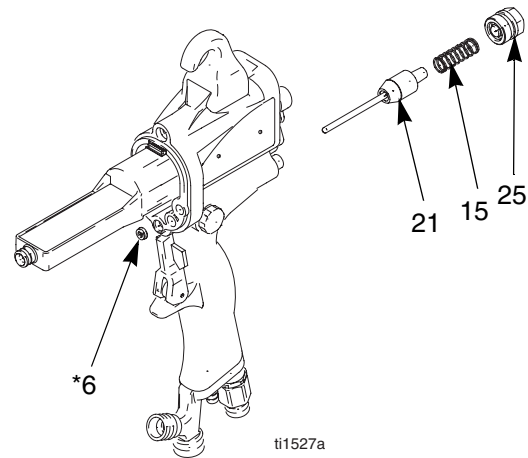

Fig. 20. Air Valve

## ES ON/OFF Valve Repair

1. Prepare the gun for service, page 26.
2. Loosen the screw (48). Remove the valve.
3. Lubricate the o-rings (22a\* and 22b\*) with non-silicone grease, Part No. 111265. Do not over-lubricate.

### CAUTION

Do not over-lubricate parts. Excessive lubricant on the o-rings can be pushed into the gun air passage and blemish the finish on the workpiece.

4. Clean and inspect parts for damage. Replace if necessary.

**NOTE:** The protrusion on the retainer plate (22d) must point upward.

5. Reinstall the valve. Torque the screw (48) to 15-25 in-lb (1.7-2.8 N•m).

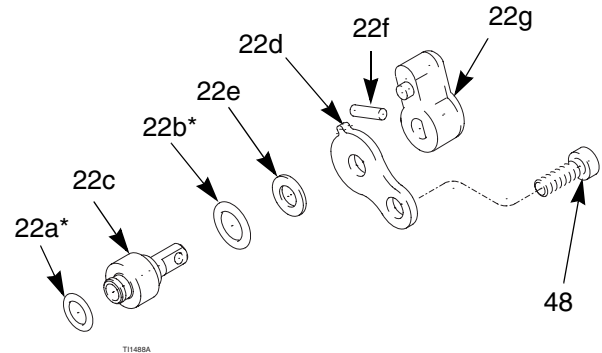
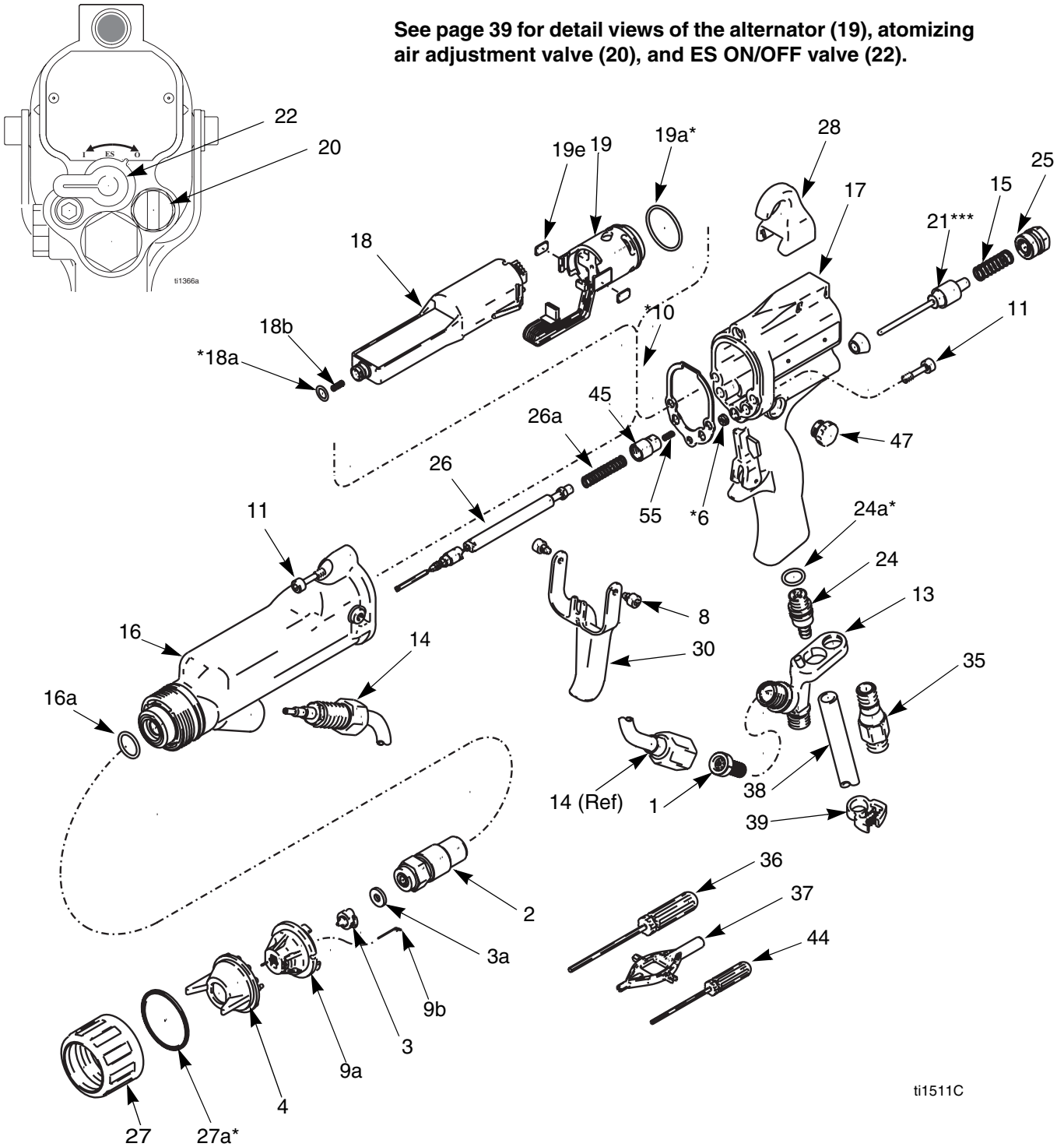

**Fig. 21. ES ON/OFF Valve**

# Parts

Part No. 244572 85 kV Electrostatic Gun, Series C (items 1-50)

See page 39 for detail views of the alternator (19), atomizing air adjustment valve (20), and ES ON/OFF valve (22).



tt1511C

**Ref. No. 19: Alternator**

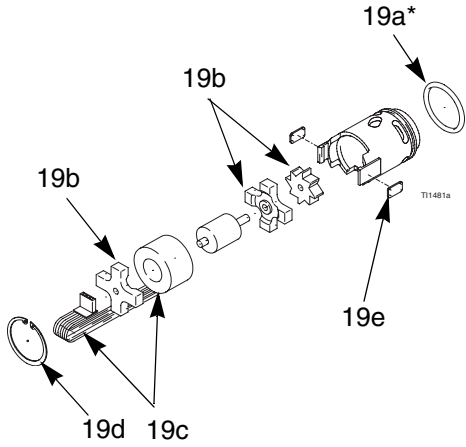

**Ref. No. 20: Atomizing Air Adjustment Valve**

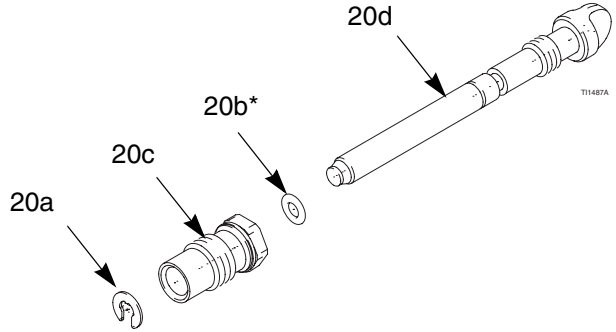

**Ref. No. 22: ES ON/OFF Valve**

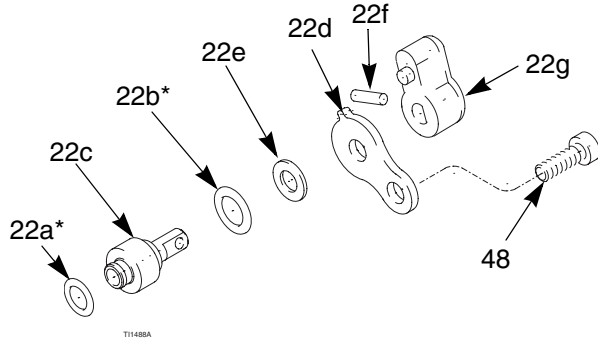

**Part No. 244572 85 kV Electrostatic Gun, Series C (items 1-50)**

Ref. No.	Part No.	Description	Qty	Ref. No.	Part No.	Description	Qty
1	205264	FILTER, fluid, inline	1	20	244556	VALVE, adjustment, atomizing air; includes items 20a-20d	1
2	245280	HOUSING, seat	1	20a	101021	. RING, retaining	1
3	GG3XXX	SPRAY TIP (customer's choice); includes item 3a	1	20b*	106560	. O-RING; fluorocarbon	1
3a	183459	. SEAL, spray tip	1	20c	197566	. HOUSING, valve	1
4	276767	TIP GUARD	1	20d	197567	. STEM, valve	1
6*	188749	PACKING, u-cup, air valve; UHMWPE	1	21***	244557	VALVE, air;	1
8	197369	SCREW, trigger	2	22	244558	VALVE, electrostatics, ON/OFF; includes items 22a-22g	1
9	245276	AIR CAP ASSEMBLY; includes items 9a and 9b	1	22a*	111516	. O-RING; CV75	1
9a	198679	. AIR CAP	1	22b*	113137	. O-RING; fluoroelastomer	1
9b	244917	. ELECTRODE (kit of 5)	1	22c	198403	. SHAFT, valve	1
10*	197517	GASKET, barrel	1	22d	198404	. PLATE, retaining	1
11	197518	SCREW; socket-hd; 10-24 x 3/4 in. (19 mm)	3	22e	198453	. WASHER	1
13	15M680	BRACKET, inlet, fluid	1	22f	198464	. PIN	1
14	244713	TUBE, fluid	1	22g	276753	. KNOB	1
15	185116	SPRING, compression	1	24	249323	VALVE, exhaust; includes item 24a	1
16	244531	BARREL, gun; includes item 16a	1	24a*	112085	. O-RING; fluorocarbon	1
16a	197486	. O-RING; conductive	1	25	197966	CAP, air valve	1
17	245286	HANDLE, gun (includes item 28)	1	26	244714	NEEDLE, fluid; includes item 26a	1
18	244541	POWER SUPPLY, 85 kV; includes items 18a-18b	1	26a	112691	. SPRING, compression	1
18a*	103337	. O-RING; fluoroelastomer	1	27	244927	RING, retaining, air cap; includes item 27a	1
18b	197624	. SPRING, compression	1	27a*	198307	. PACKING, u-cup	1
19	244555	TURBINE, alternator; includes items 19a-19e	1	28	276695	HOOK	1
19a*	110073	. O-RING; fluoroelastomer	1	30	276698	TRIGGER	1
19b	223688	. BEARING KIT; includes front and rear bearings and fan	1	35	185105	FITTING, air; left-hand threads	1
19c	244577	. COIL	1	36	107460	WRENCH, ball end; 4 mm	1
19d	111745	. RING, retaining	1	37	276741	MULTI-TOOL	1
19e	198821	. PAD, pressure	2	38	185103	TUBE, exhaust	1
				39	110231	CLAMP	1
				40	116553	GREASE, dielectric, tube (not shown)	1



Ref. No.	Part No.	Description	Qty	Ref. No.	Part No.	Description	Qty
41	244915	COVER, gun; box of 10 (not shown)	1	48	198058	SCREW, cap, socket hd	1
42	179791	TAG, warning (not shown); replacement available at no cost	1	49	222385	CARD, warning (not shown); replacement available at no cost	1
43	180060	SIGN, warning (not shown); replacement available at no cost	1	50	188774	TAG, warning (not shown); replacement available at no cost	1
44	112080	TOOL, needle; 2 mm	1	* Included in Air Seal Repair Kit 244781.			
45	198516	CAP, spring		*** Rubber seal is not removable.			
47	197967	PLUG	1	Replacement Warning labels, signs, tags, and cards are available at no cost.			

Part No. 244573 85 kV Electrostatic Gun, Series C (items 1-59)

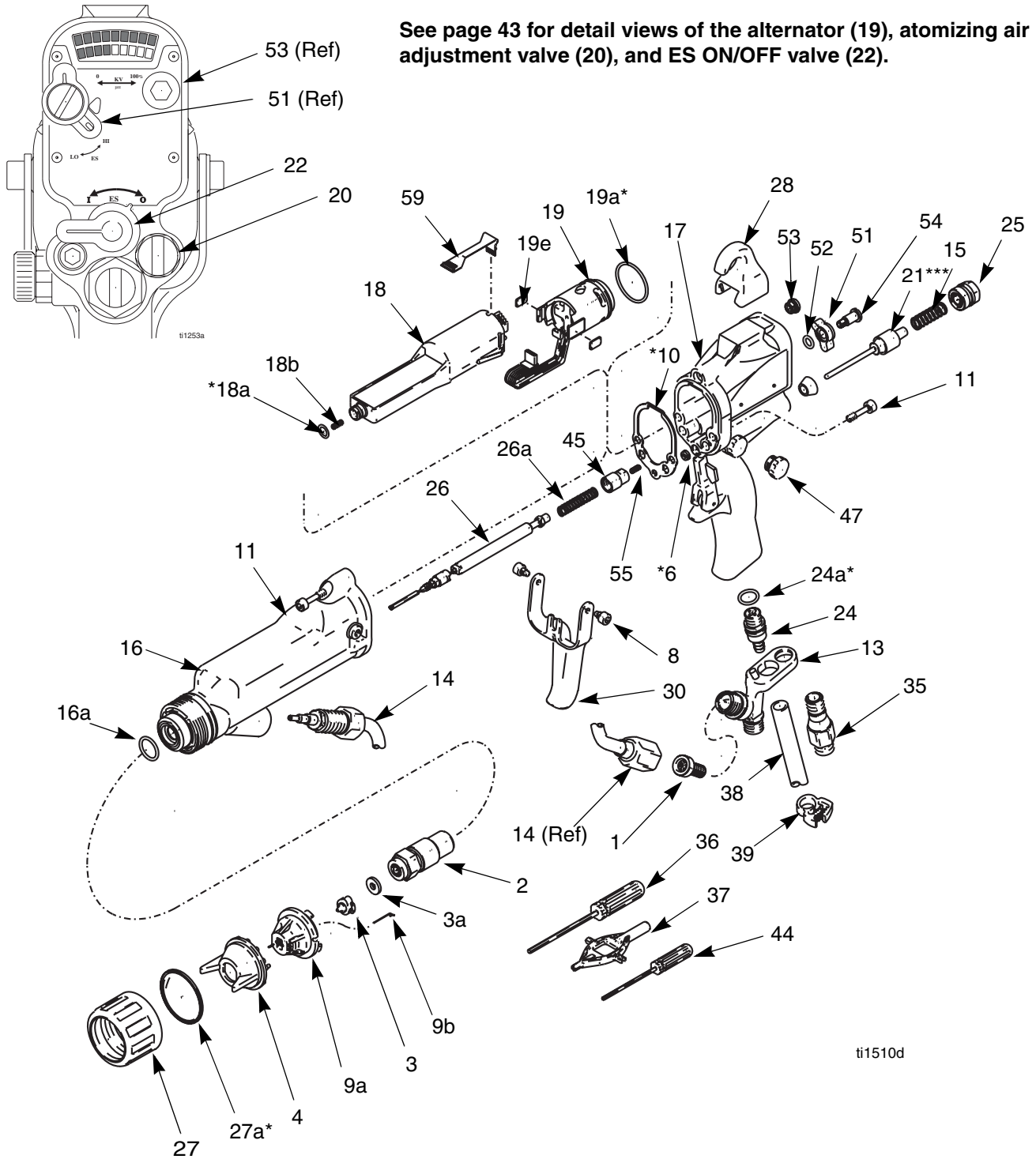

**Ref. No. 19: Alternator**

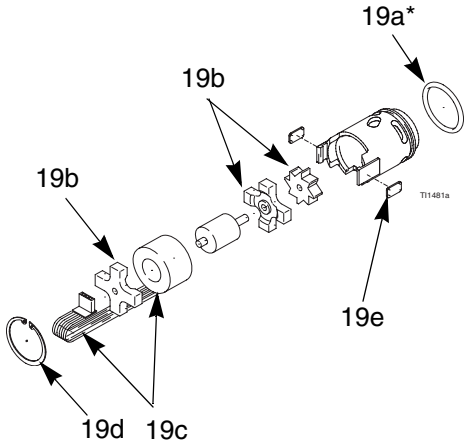

**Ref. No. 20: Atomizing Air Adjustment Valve**

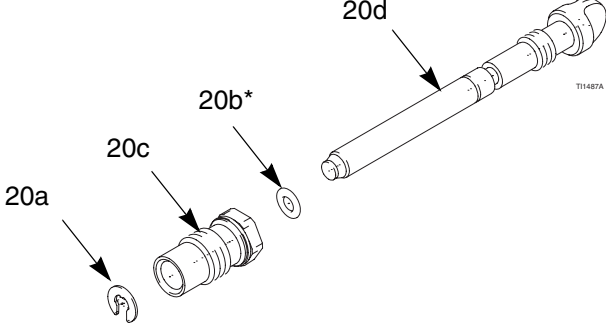

**Ref. No. 22: ES ON/OFF Valve**

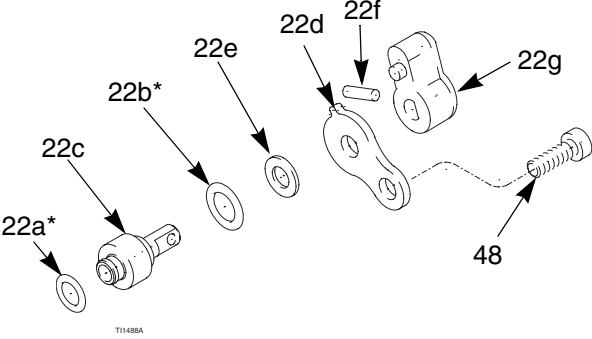

**Part No. 244573 85 kV Electrostatic Gun, Series C (items 1-59)**

Ref. No.	Part No.	Description	Qty	Ref. No.	Part No.	Description	Qty
				20	244556	VALVE, adjustment, atomizing air; includes items 20a-20d	1
1	205264	FILTER, fluid, inline	1	20a	101021	. RING, retaining	1
2	245280	HOUSING, seat	1	20b*	106560	. O-RING; fluorocarbon	1
3	GG3XXX	SPRAY TIP (customer's choice); includes item 3a	1	20c	197566	. HOUSING, valve	1
3a	183459	. SEAL, spray tip	1	20d	197567	. STEM, valve	1
4	276767	TIP GUARD	1	21***	244557	VALVE, air	1
6*	188749	PACKING, u-cup, air valve; UHMWPE	1	22	244558	VALVE, electrostatics, ON/OFF; includes items 22a-22g	1
8	197369	SCREW, trigger	2	22a*	111516	. O-RING; CV75	1
9	245276	AIR CAP ASSEMBLY	1	22b*	113137	. O-RING; fluoroelastomer	1
9a	198679	. AIR CAP	1	22c	198403	. SHAFT, valve	1
9b	244917	. ELECTRODE (kit of 5)	1	22d	198404	. PLATE, retaining	1
10*	197517	GASKET, barrel	1	22e	198453	. WASHER	1
11	197518	SCREW; socket-hd; 10-24 x 3/4 in. (19 mm)	3	22f	198464	. PIN	1
				22g	276753	. KNOB	1
13	15M680	BRACKET, inlet, fluid	1	24	249323	VALVE, exhaust; includes item 24a	1
14	244713	TUBE, fluid	1	24a*	112085	. O-RING; fluorocarbon	1
15	185116	SPRING, compression	1	25	197966	CAP, air valve	1
16	244531	BARREL, gun; includes item 16a	1	26	244714	NEEDLE, fluid; includes item 26a	1
16a	197486	. O-RING; conductive	1	26a	112691	. SPRING, compression	1
17	245288	HANDLE, gun (includes item 28)	1	27	244927	RING, retaining, air cap; includes item 27a	1
18	244541	POWER SUPPLY, 85 kV; includes items 18a-18b	1	27a*	198307	. PACKING, u-cup	1
18a*	103337	. O-RING; fluoroelastomer	1	28	276695	HOOK	1
18b	197624	. SPRING, compression	1	30	276698	TRIGGER	1
19	244555	TURBINE, alternator; includes items 19a-19e	1	35	185105	FITTING, air; left-hand threads	1
19a*	110073	. O-RING; fluoroelastomer	1	36	107460	WRENCH, ball end; 4 mm	1
19b	223688	. BEARING KIT; includes front and rear bearings and fan	1	37	276741	MULTI-TOOL	1
19c	244577	. COIL	1	38	185103	TUBE, exhaust	1
19d	111745	. RING, retaining	1	39	110231	CLAMP	1
19e	198821	. PAD, pressure	2				

Ref. No.	Part No.	Description	Qty	Ref. No.	Part No.	Description	Qty
40	116553	GREASE, dielectric, tube (not shown)	1	50	188774	TAG, warning (not shown); replacement available at no cost	1
41	244915	COVER, gun; box of 10 (not shown)	1	51	244627	SWITCH, ES HI/LO	1
42	179791	TAG, warning (not shown); replacement available at no cost	1	52	111450	O-RING	1
43	180060	SIGN, warning (not shown); replacement available at no cost	1	53	276734	PLUG, LO voltage adjustment	1
44	112080	TOOL, needle; 2 mm	1	54	197910	SCREW, pivot	1
45	198516	CAP, spring		55	197624	SPRING, grounding	1
47	197967	PLUG	1	59	245265	CIRCUIT, flexible	1
48	198058	SCREW, cap, socket hd	1	* Included in Air Seal Repair Kit 244781.			
49	222385	CARD, warning (not shown); replacement available at no cost	1	*** Rubber seal is not removable.			
				Replacement Warning labels, signs, tags, and cards are available at no cost.			

# Accessories

## Air Line Accessories

### AirFlex™ Flexible Grounded Air Hose

100 psi (7 bar, 0.7 MPa) Maximum Working Pressure  
0.315 in. (8 mm) ID; 1/4 npsm(f) x 1/4 npsm(f) left-hand thread

<b>244963</b>	6 ft (1.8 m)
<b>244964</b>	15 ft (4.6 m)
<b>244965</b>	25 ft (7.6 m)
<b>244966</b>	36 ft (11 m)
<b>244967</b>	50 ft (15 m)
<b>244968</b>	75 ft (23 m)
<b>244969</b>	100 ft (30.5 m)

### Standard Grounded Air Hose

100 psi (7 bar, 0.7 MPa) Maximum Working Pressure  
0.315 in. (8 mm) ID; 1/4 npsm(f) x 1/4 npsm(f) left-hand thread

<b>223068</b>	6 ft (1.8 m)
<b>223069</b>	15 ft (4.6 m)
<b>223070</b>	25 ft (7.6 m)
<b>223071</b>	36 ft (11 m)
<b>223072</b>	50 ft (15 m)
<b>223073</b>	75 ft (23 m)
<b>223074</b>	100 ft (30.5 m)

### Grounded Air Whip Hose

100 psi (7 bar, 0.7 MPa) Maximum Working Pressure  
0.188 in. (5 mm) ID; 1/4 npsm(m) x 1/4 npsm(f) left-hand threads

<b>236130</b>	3 ft (0.9 m)
<b>236131</b>	6 ft (1.8 m)

### Bleed-Type Master Air Valve

300 psi (21 bar, 2.1 MPa) Maximum Working Pressure  
Relieves air trapped in the air line between this valve and the pump air motor when closed.

<b>107141</b>	3/4 npt
---------------	---------

### Air Line Shutoff Valve

150 psi (10 bar, 1.0 MPa) Maximum Working Pressure  
For turning air to gun on or off.

<b>224754</b>	1/4 npsm(m) x 1/4 npsm(f) left-hand thread.
---------------	---

### Air Line Quick Disconnect

<b>112534</b>	Swiveling quick disconnect replaces standard air inlet swivel.
---------------	--

### Air Hose Adapter Nipple

<b>185493</b>	Use to connect multiple air hoses. 1/4 npt x 1/4 npsm left-hand thread.
---------------	---

### Non-Swivel Air Inlet Fitting

<b>185105</b>	Replaces standard swivel. Left-hand thread.
---------------	---

### Extended Air Inlet Fitting

<b>189191</b>	Replaces standard swivel to provide extended handle grip area. Left-hand thread.
---------------	--

## Fluid Line Accessories

### Nylon Fluid Hose

3000 psi (210 bar, 21 MPa) Maximum Working Pressure

<b>223540</b>	1/4 in. (6 mm) ID x 25 ft (7.6 m), 1/4 npsm
<b>223541</b>	1/4 in. (6 mm) ID x 50 ft (15.2 m), 1/4 npsm

### Fluid Whip Hose

3000 psi (210 bar, 21 MPa) Maximum Working Pressure  
0.125 in. (3 mm) ID; 1/4 npsm(f) x 1/4 npt(m)

<b>236134</b>	3 ft (0.9 m)
<b>236135</b>	6 ft (1.8 m)

### Fluid Shutoff/Drain Valve

5000 psi (350 bar, 35 MPa) Maximum Working Pressure  
For turning fluid on or off to the gun and for relieving fluid line pressure at the pump.

<b>210657</b>	1/2 npt(m), Fluoroelastomer seals
<b>210658</b>	3/8 npt(m), Fluoroelastomer seals
<b>210659</b>	3/8 npt x 1/4 npt(m), Fluoroelastomer seals
<b>214037</b>	1/4 npt(m), PTFE seals

### Fluid Swivel

5800 psi (405 bar, 40 MPa) Maximum Working Pressure

<b>115898</b>	1/4 npsm(m) x 1/4 npsm(f)
---------------	---------------------------

## Gun Accessories

### Gun Repair Kit

**244781** Air Seal Repair Kit

### Electrode Replacement Kit

**244917** Includes five electrodes.

### Inline Fluid Filters

**238561** 100 mesh filter. Set of three.

**238563** 60 mesh filter. Set of three.

### Round Pattern Kit

Provides higher level of performance to electrostatic spraying.

**245282** Includes tip of choice.

### ES Always On Kit

**244913** Replaces inlet fitting with ball valve to shut off air during flushing. Converts ES ON/OFF valve to always ON condition.

### Handle Grips

**245263** Medium Grip

**245264** Large Grip

### Gun Washer Kit

**245271** Use to convert Graco gun washers so they can clean PRO Xs4 air-assisted spray guns.

### Gun Valve Lubricant

**111265** 4 oz (113 g) tube of sanitary (non-silicone) lubricant for fluid seals and wear areas.

### Alternator Bearing Kit

**223688** To repair the turbine alternator.

### Cleaning Brush

**105749** For cleaning air cap and fluid nozzle.

## Miscellaneous Accessories

### Ground Wire and Clamp

**222011** For grounding pump and other components and equipment in the spray area.  
12 gauge, 25 ft (7.6 m).

### Megohmmeter

**241079** 500 Volt output; 0.01-2000 megohms.  
**Not for use in hazardous areas.**

### Paint Resistance Meter

**722886** Use with 722860 Paint Probe to measure resistance of paint.  
**Not for use in hazardous areas.**

### Paint Probe

**722860** Use with 722886 Paint Resistance Meter to measure resistance of paint.  
**Not for use in hazardous areas.**

### Safety Warning Sign

**180060** English Warning Sign. FM Approved. Available at no charge from Graco.

### Instruction Signs

**198310** English Setup Instructions.

**198320** English Daily Care Instructions.

### Electrostatic Conductive Gloves (box of 12)

**117823** Small

**117824** Medium

**117825** Large

# Spray Tip Selection Chart

Part No.	Fan Width at 10 in. (250 mm) in. (mm)	Orifice Size in. (mm)
GG3107	2-4 (50-100)	0.007 (0.178)
GG3207	4-6 (100-150)	
GG3307	6-8 (150-200)	
GG3209	4-6 (100-150)	0.009 (0.229)
GG3309	6-8 (150-200)	
GG3409	8-10 (200-250)	
GG3211	4-6 (100-150)	0.011 (0.279)
GG3311	6-8 (150-200)	
GG3411	8-10 (200-250)	
GG3511	10-12 (250-300)	
GG3611	12-14 (300-350)	
GG3213	4-6 (100-150)	0.013 (0.330)
GG3313	6-8 (150-200)	
GG3413	8-10 (200-250)	
GG3513	10-12 (250-300)	
GG3613	12-14 (300-350)	
GG3215	4-6 (100-150)	0.015 (0.381)
GG3315	6-8 (150-200)	
GG3415	8-10 (200-250)	
GG3515	10-12 (250-300)	
GG3615	12-14 (300-350)	

Part No.	Fan Width at 10 in. (250 mm) in. (mm)	Orifice Size in. (mm)
GG3217	4-6 (100-150)	0.017 (0.432)
GG3317	6-8 (150-200)	
GG3417	8-10 (200-250)	
GG3517	10-12 (250-300)	
GG3617	12-14 (300-350)	
GG3319	6-8 (150-200)	0.019 (0.483)
GG3419	8-10 (200-250)	
GG3519	10-12 (250-300)	
GG3619	12-14 (300-350)	
GG3719	14-16 (350-400)	
GG3421	8-10 (200-250)	0.021 (0.533)
GG3521	10-12 (250-300)	
GG3621	12-14 (300-350)	
GG3721	14-16 (350-400)	
GG3821	16-18 (400-450)	
GG3423	8-10 (200-250)	0.023 (0.584)
GG3523	10-12 (250-300)	
GG3623	12-14 (300-350)	
GG3723	14-16 (350-400)	
GG3823	16-18 (400-450)	
GG3425	8-10 (200-250)	0.025 (0.635)
GG3525	10-12 (250-300)	
GG3625	12-14 (300-350)	
GG3725	14-16 (350-400)	
GG3825	16-18 (400-450)	



# Technical Data

Category	Data
Maximum Working Fluid Pressure	3000 psi (21 MPa, 210 bar)
Maximum Working Air Pressure	100 psi (0.7 MPa, 7 bar)
Minimum Air Pressure to Gun Inlet	40 psi (0.28 MPa, 2.8 bar)
Maximum Fluid Operating Temperature	120°F (48°C)
Paint Resistivity Range	3 megohm/cm to infinity
Short Circuit Current Output	125 microamperes
Voltage Output	PRO Xs4 AA (244572): 85 kV PRO Xs4 AA (244573): 40-85 kV
Sound Power (measured per ISO Standard 9216)	at 40 psi (0.28 MPa, 2.8 bar): 88.9 dB(A) at 100 psi (0.7 MPa, 7 bar): 99.7 dB(A)
Sound Pressure (measured 1 m from gun)	at 40 psi (0.28 MPa, 2.8 bar): 86.0 dB(A) at 100 psi (0.7 MPa, 7 bar): 95.0 dB(A)
Air inlet fitting, left-hand thread	1/4 npsm(m)
Fluid inlet fitting	1/4-18 npsm(m)
Gun Weight	29.1 oz (825 g)
Gun Length	11.4 in. (29 cm)
Wetted Parts	Stainless Steel; Nylon, Acetal, Ultra-High Molecular Weight Polyethylene, Fluoroelastomer, PEEK, Tungsten Wire, Polyethylene

*Loctite® is a registered trademark of the Loctite Corporation.*

# Graco Standard Warranty

Graco warrants all equipment manufactured by Graco and bearing its name to be free from defects in material and workmanship on the date of sale to the original purchaser for use. With the exception of any special, extended, or limited warranty published by Graco, Graco will, for a period of twelve months or two thousand hours of operation from the date of sale, repair or replace any part of the equipment determined by Graco to be defective. However, any deficiency in the barrel, handle, trigger, hook, internal power supply, and alternator (excluding turbine bearings) will be repaired or replaced for thirty-six months or six thousand hours of operation from the date of sale. This warranty applies only when the equipment is installed, operated and maintained in accordance with Graco's written recommendations.

This warranty does not cover, and Graco shall not be liable for general wear and tear, or any malfunction, damage or wear caused by faulty installation, misapplication, abrasion, corrosion, inadequate or improper maintenance, negligence, accident, tampering, or substitution of non-Graco component parts. Nor shall Graco be liable for malfunction, damage or wear caused by the incompatibility of Graco equipment with structures, accessories, equipment or materials not supplied by Graco, or the improper design, manufacture, installation, operation or maintenance of structures, accessories, equipment or materials not supplied by Graco.

This warranty is conditioned upon the prepaid return of the equipment claimed to be defective to an authorized Graco distributor for verification of the claimed defect. If the claimed defect is verified, Graco will repair or replace free of charge any defective parts. The equipment will be returned to the original purchaser transportation prepaid. If inspection of the equipment does not disclose any defect in material or workmanship, repairs will be made at a reasonable charge, which charges may include the costs of parts, labor, and transportation.

**THIS WARRANTY IS EXCLUSIVE, AND IS IN LIEU OF ANY OTHER WARRANTIES, EXPRESS OR IMPLIED, INCLUDING BUT NOT LIMITED TO WARRANTY OF MERCHANTABILITY OR WARRANTY OF FITNESS FOR A PARTICULAR PURPOSE.**

Graco's sole obligation and buyer's sole remedy for any breach of warranty shall be as set forth above. The buyer agrees that no other remedy (including, but not limited to, incidental or consequential damages for lost profits, lost sales, injury to person or property, or any other incidental or consequential loss) shall be available. Any action for breach of warranty must be brought within two (2) years of the date of sale.

Graco makes no warranty, and disclaims all implied warranties of merchantability and fitness for a particular purpose in connection with accessories, equipment, materials or components sold but not manufactured by Graco. These items sold, but not manufactured by Graco (such as electric motors, switches, hose, etc.), are subject to the warranty, if any, of their manufacturer. Graco will provide purchaser with reasonable assistance in making any claim for breach of these warranties.

In no event will Graco be liable for indirect, incidental, special or consequential damages resulting from Graco supplying equipment hereunder, or the furnishing, performance, or use of any products or other goods sold hereto, whether due to a breach of contract, breach of warranty, the negligence of Graco, or otherwise.

## **FOR GRACO CANADA CUSTOMERS**

The parties acknowledge that they have required that the present document, as well as all documents, notices and legal proceedings entered into, given or instituted pursuant hereto or relating directly or indirectly hereto, be drawn up in English. Les parties reconnaissent avoir convenu que la rédaction du présente document sera en Anglais, ainsi que tous documents, avis et procédures judiciaires exécutés, donnés ou intentés à la suite de ou en rapport, directement ou indirectement, avec les procédures concernées.

# Graco Information

**TO PLACE AN ORDER**, contact your Graco distributor, or call this number to identify the distributor closest to you:

**1-800-328-0211 Toll Free**

**612-623-6921**

**612-378-3505 Fax**

*All written and visual data contained in this document reflects the latest product information available at the time of publication. Graco reserves the right to make changes at any time without notice.*

This manual contains English. MM 309295

**Graco Headquarters:** Minneapolis

**International Offices:** Belgium, China, Japan, Korea

**GRACO INC. P.O. BOX 1441 MINNEAPOLIS, MN 55440-1441**

Copyright 2001, Graco Inc. is registered to I.S. EN ISO 9001

[www.graco.com](http://www.graco.com)

Revised 8/2008